

## RF & MICROWAVE TRANSISTORS AVIONICS APPLICATIONS

- 1025 - 1150 MHz
- RUGGEDIZED VSWR  $\infty:1$
- INTERNAL INPUT MATCHING
- LOW THERMAL RESISTANCE
- $P_{OUT} = 4.0 \text{ W MIN. WITH } 9.0 \text{ dB GAIN}$

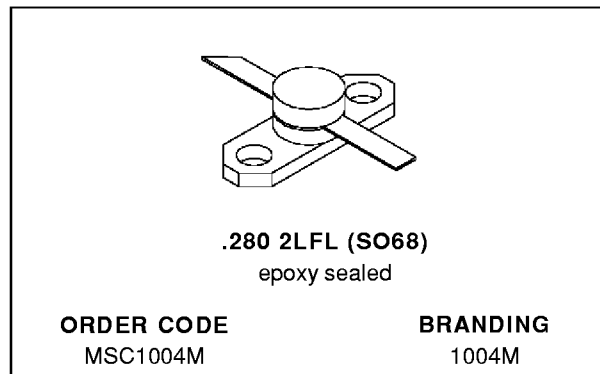

### DESCRIPTION

The MSC1004M is a low-level Class C pulsed transistor specifically designed for DME/IFF driver or output applications.

These devices are capable of withstanding a  $\infty:1$  load VSWR at any phase angle under full rated conditions. Low RF thermal resistance and automatic bonding techniques ensure high reliability and product consistency.

The MSC1004M is housed in the IMPAC™ package with internal input matching.

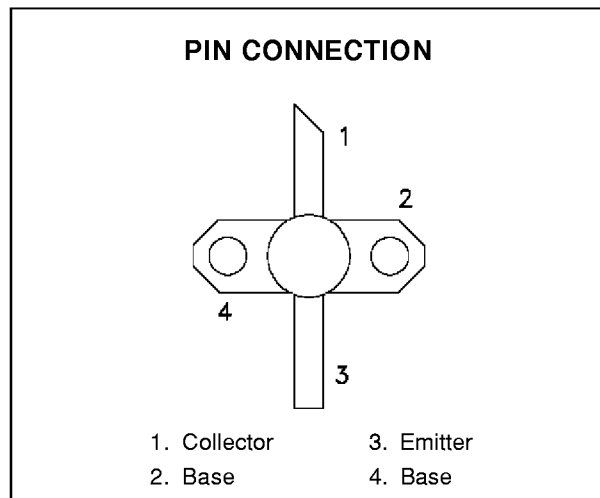

### ABSOLUTE MAXIMUM RATINGS ( $T_{case} = 25^{\circ}\text{C}$ )

Symbol	Parameter	Value	Unit
$P_{DISS}$	Power Dissipation* ( $T_C \leq 100^{\circ}\text{C}$ )	18	W
$I_C$	Device Current*	650	mA
$V_{CC}$	Collector-Supply Voltage*	32	V
$T_J$	Junction Temperature	200	$^{\circ}\text{C}$
$T_{STG}$	Storage Temperature	- 65 to +150	$^{\circ}\text{C}$

### THERMAL DATA

$R_{TH(j-c)}$	Junction-Case Thermal Resistance*	5	$^{\circ}\text{C/W}$
---------------	-----------------------------------	---	----------------------

\*Applies only to rated RF amplifier operation

**ELECTRICAL SPECIFICATIONS** ( $T_{case} = 25^{\circ}C$ )

STATIC

Symbol	Test Conditions		Value			Unit
			Min.	Typ.	Max.	
$BV_{CBO}$	$I_C = 1\text{ mA}$	$I_E = 0\text{ mA}$	45	—	—	V
$BV_{CER}$	$I_C = 5\text{ mA}$	$R_{BE} = 10\ \Omega$	45	—	—	V
$BV_{EBO}$	$I_E = 1\text{ mA}$	$I_C = 0\text{ mA}$	3.5	—	—	V
$I_{CES}$	$V_{CE} = 28\text{ V}$		—	—	1.0	mA
$h_{FE}$	$V_{CE} = 5\text{ V}$	$I_C = 200\text{ mA}$	30	—	300	—

DYNAMIC

Symbol	Test Conditions			Value			Unit
				Min.	Typ.	Max.	
$P_{OUT}$	$f = 1025 - 1150\text{ MHz}$	$P_{IN} = 500\text{ mW}$	$V_{CC} = 28\text{ V}$	4.0	—	—	W
$\eta_C$	$f = 1025 - 1150\text{ MHz}$	$P_{IN} = 500\text{ mW}$	$V_{CC} = 28\text{ V}$	35	—	—	%
$G_P$	$f = 1025 - 1150\text{ MHz}$	$P_{IN} = 500\text{ mW}$	$V_{CC} = 28\text{ V}$	9.0	—	—	dB

Note: Pulse Width =  $10\ \mu\text{Sec}$   
 Duty Cycle = 1%

**TEST CIRCUIT**

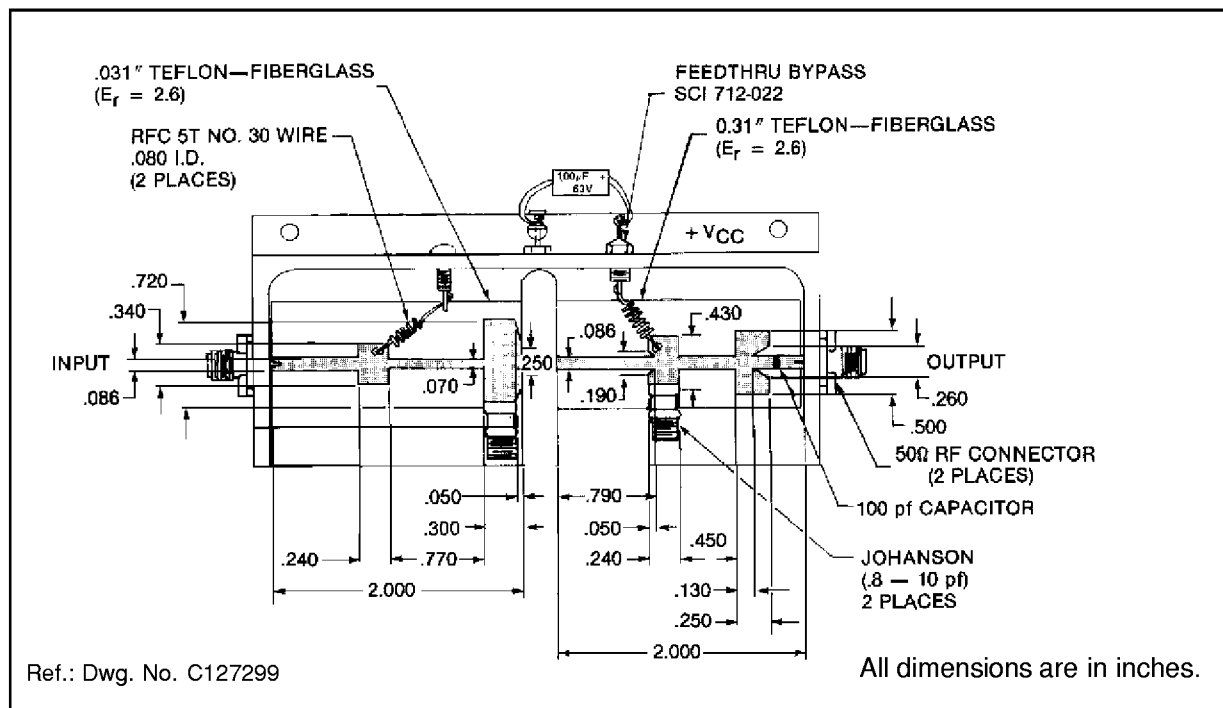

**PACKAGE MECHANICAL DATA**

Ref.: Dwg. No. 12-0218 rev. A

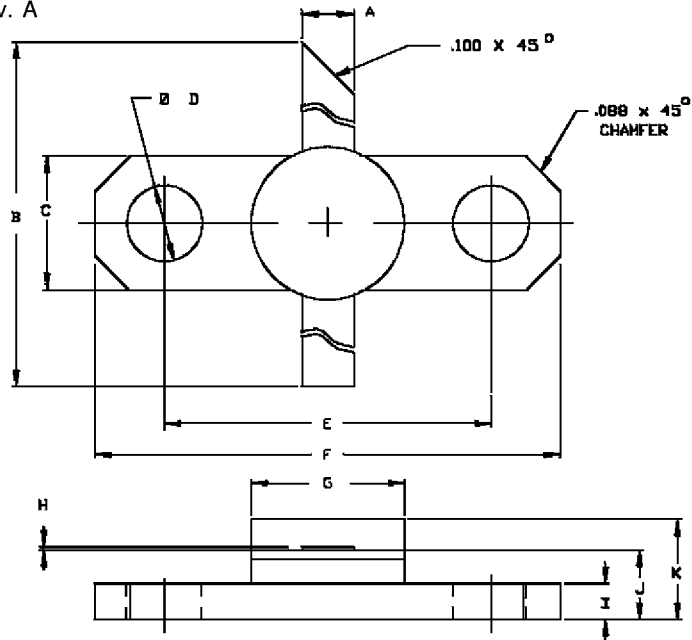

SGS-THOMSON MICROELECTRONICS			CONT'D		
	MINIMUM Inches/mm	MAXIMUM Inches/mm		MINIMUM Inches/mm	MAXIMUM Inches/mm
A	.095/2,41	.105/2,67	I	.052/1,32	.072/1,83
B	1.050/26,67		J	.120/3,05	.130/3,30
C	.245/6,22	.255/6,48	K		.210/5,33
D	.120/3,05	.140/3,56			
E	.552/14,02	.572/14,53			
F	.790/20,07	.810/20,57			
G		.285/7,24			
H	.003/0,08	.007/0,18			

Information furnished is believed to be accurate and reliable. However, SGS-THOMSON Microelectronics assumes no responsibility for the consequences of use of such information nor for any infringement of patents or other rights of third parties which may result from its use. No license is granted by implication or otherwise under any patent or patent rights of SGS-THOMSON Microelectronics. Specifications mentioned in this publication are subject to change without notice. This publication supersedes and replaces all information previously supplied. SGS-THOMSON Microelectronics products are not authorized for use as critical components in life support devices or systems without express written approval of SGS-THOMSON Microelectronics.

©1995 SGS-THOMSON Microelectronics - All Rights Reserved

SGS-THOMSON Microelectronics GROUP OF COMPANIES

Australia - Brazil - France - Germany - Hong Kong - Italy - Japan - Korea - Malaysia - Malta - Morocco - The Netherlands - Singapore - Spain - Sweden - Switzerland - Taiwan - Thailand - United Kingdom - U.S.A.