

SN54174, SN54175, SN54LS174, SN54LS175, SN54S174, SN54S175, SN74174, SN74175, SN74LS174, SN74LS175, SN74S174, SN74S175
HEX/QUADRUPLE D-TYPE FLIP-FLOPS WITH CLEAR

DECEMBER 1972—REVISED MARCH 1988

'174, 'LS174, 'S174 . . . HEX D-TYPE FLIP-FLOPS
 '175, 'LS175, 'S175 . . . QUADRUPLE D-TYPE FLIP-FLOPS

- '174, 'LS174, 'S174 Contain Six Flip-Flops with Single-Rail Outputs
- '175, 'LS175, 'S175 Contain Four Flip-Flops with Double-Rail Outputs
- Three Performance Ranges Offered: See Table Lower Right
- Buffered Clock and Direct Clear Inputs
- Individual Data Input to Each Flip-Flop
- Applications include:
 Buffer/Storage Registers
 Shift Registers
 Pattern Generators

SN54174, SN54LS174, SN54S174 . . . J OR W PACKAGE
 SN74174 . . . N PACKAGE
 SN74LS174, SN74S174 . . . D OR N PACKAGE

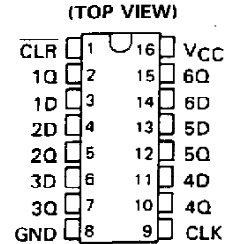

SN54LS174, SN54S174 . . . FK PACKAGE
 (TOP VIEW)

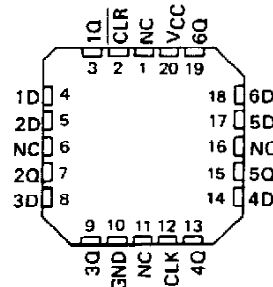

SN54175, SN54LS175, SN54S175 . . . J OR W PACKAGE
 SN74175 . . . N PACKAGE
 SN74LS175, SN74S175 . . . D OR N PACKAGE

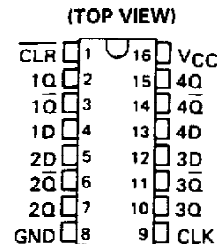

SN54LS175, SN54S175 . . . FK PACKAGE
 (TOP VIEW)

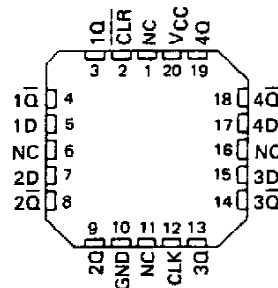

NC - No internal connection

description

These monolithic, positive-edge-triggered flip-flops utilize TTL circuitry to implement D-type flip-flop logic. All have a direct clear input, and the '175, 'LS175, and 'S175 feature complementary outputs from each flip-flop.

Information at the D inputs meeting the setup time requirements is transferred to the Q outputs on the positive-going edge of the clock pulse. Clock triggering occurs at a particular voltage level and is not directly related to the transition time of the positive-going pulse. When the clock input is at either the high or low level, the D input signal has no effect at the output.

These circuits are fully compatible for use with most TTL circuits.

FUNCTION TABLE
 (EACH FLIP-FLOP)

INPUTS			OUTPUTS	
CLEAR	CLOCK	D	Q	\bar{Q}
L	X	X	L	H
H	↑	H	H	L
H	↑	L	L	H
H	L	X	Q_0	\bar{Q}_0

- H = high level (steady state)
- L = low level (steady state)
- X = irrelevant
- ↑ = transition from low to high level
- Q_0 = the level of Q before the indicated steady-state input conditions were established.
- ↑ = '175, 'LS175, and 'S175 only

TYPES	TYPICAL	TYPICAL
	MAXIMUM	POWER
	CLOCK	DISSIPATION
	FREQUENCY	PER FLIP-FLOP
'174, '175	35 MHz	38 mW
'LS174, 'LS175	40 MHz	14 mW
'S174, 'S175	110 MHz	75 mW

PRODUCT PREVIEW documents contain information on products in the formative or design phase of development. Characteristic data and other specifications are design goals. Texas Instruments reserves the right to change or discontinue these products without notice.



**SN54174, SN54175, SN54LS174, SN54LS175, SN54S174, SN54S175,
SN74174, SN74175, SN74LS174, SN74LS175, SN74S174, SN74S175
HEX/QUADRUPLE D-TYPE FLIP-FLOPS WITH CLEAR**

logic symbols†

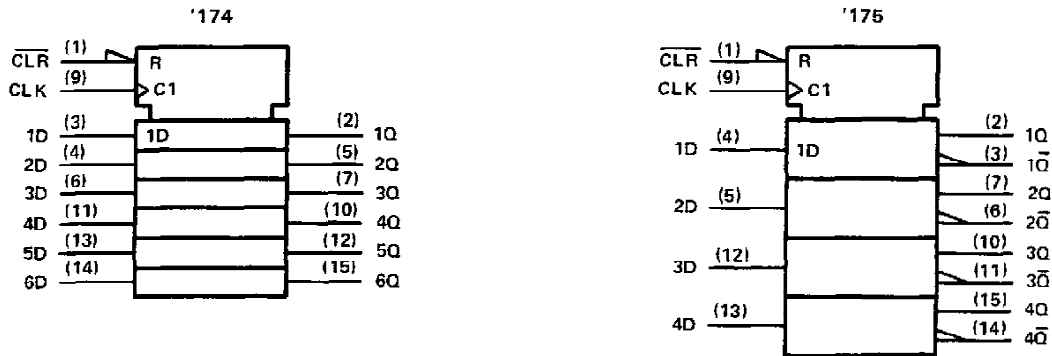

†These symbols are in accordance with ANSI/IEEE Std. 91-1984 and IEC Publication 617-12. Pin numbers shown are for D, J, N, and W packages.

logic diagrams (positive logic)

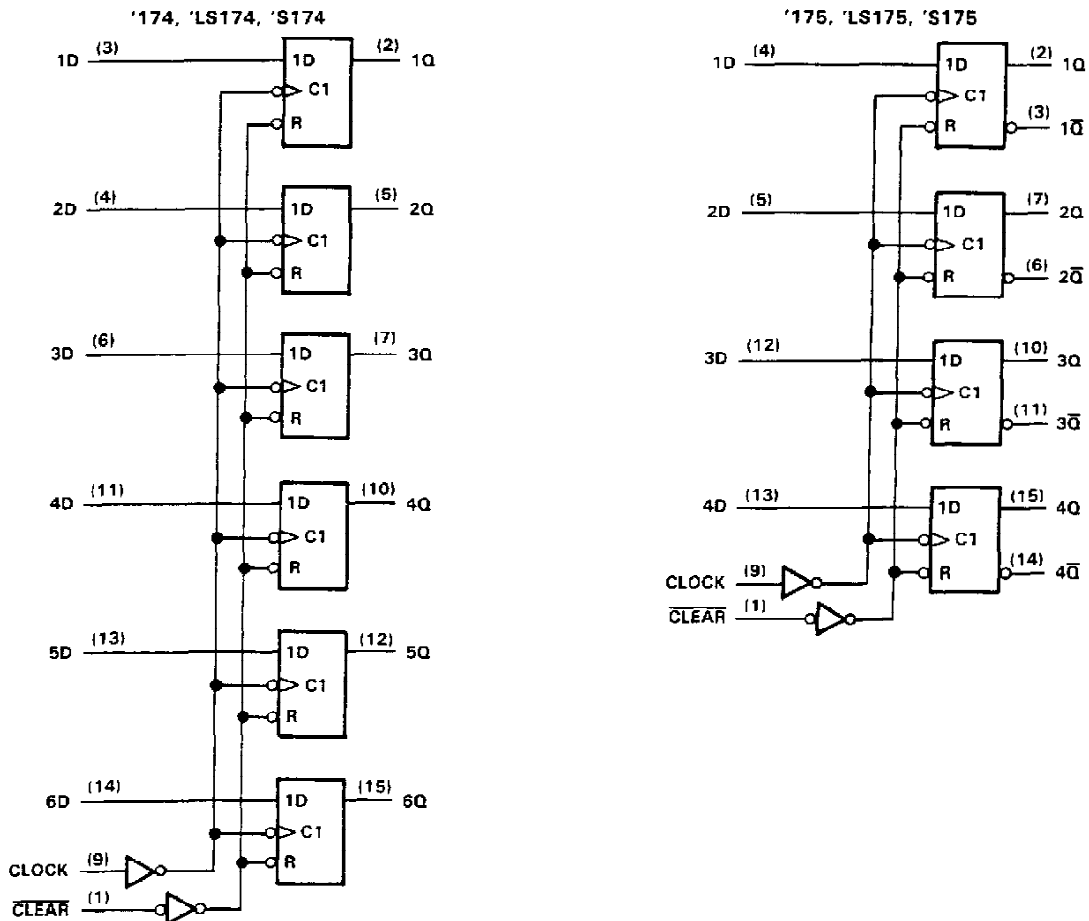

Pin numbers shown are for D, J, N, and W packages.

**TEXAS
INSTRUMENTS**

POST OFFICE BOX 655012 • DALLAS, TEXAS 75265

**SN54174, SN54175, SN54LS174, SN54LS175, SN54S174, SN54S175,
SN74174, SN74175, SN74LS174, SN74LS175, SN74S174, SN74S175
HEX/QUADRUPLE D-TYPE FLIP-FLOPS WITH CLEAR**

schematics of inputs and outputs

SN54174, SN54175, SN74174, SN74175

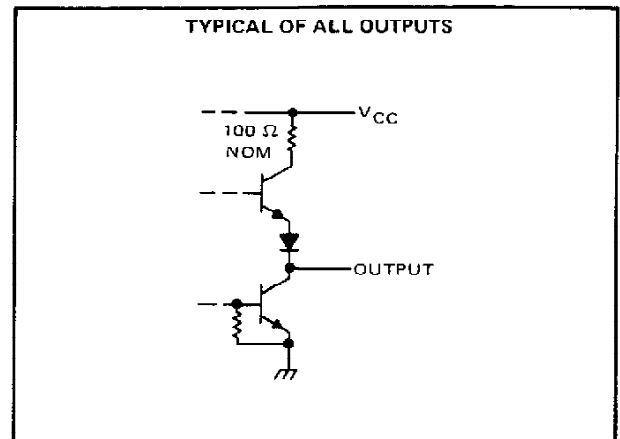
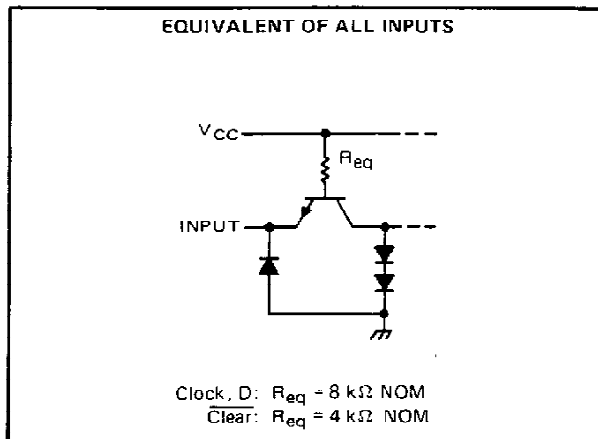

SN54LS174, SN54LS175, SN74LS174, SN74LS175

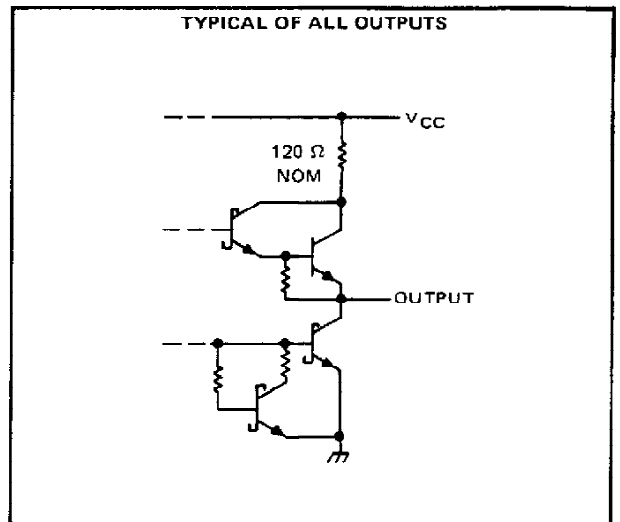
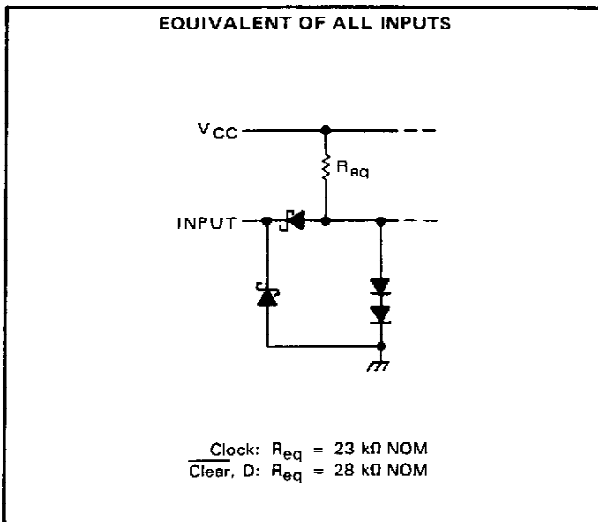

SN54S174, SN54S175, SN74S174, SN74S175

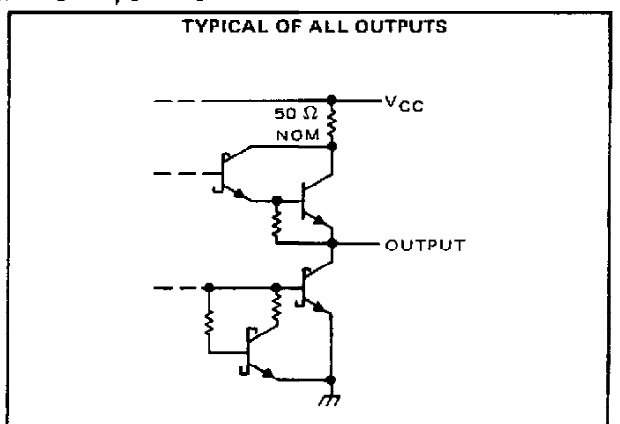
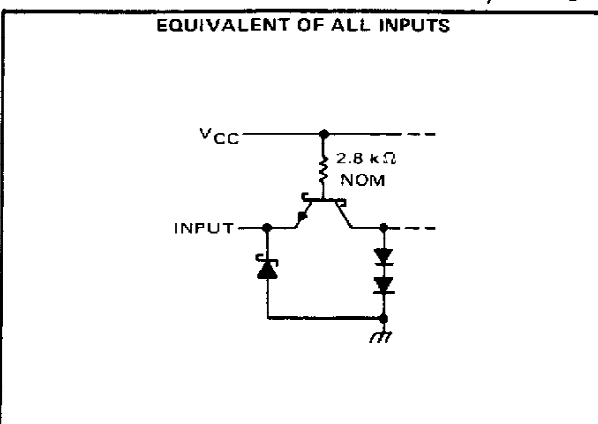

SN54174, SN54175, SN74174, SN74175 HEX/QUADRUPLE D-TYPE FLIP-FLOPS WITH CLEAR

absolute maximum ratings over operating free-air temperature range (unless otherwise noted)

Supply voltage, V_{CC} (see Note 1)	7 V
Input voltage	5.5 V
Operating free-air temperature range: SN54174, SN54175 Circuits	-55°C to 125°C
SN74174, SN74175 Circuits	0°C to 70°C
Storage temperature range	-65°C to 150°C

NOTE 1: Voltage values are with respect to network ground terminal.

recommended operating conditions

	SN54174, SN54175			SN74174, SN74175			UNIT
	MIN	NOM	MAX	MIN	NOM	MAX	
Supply voltage, V_{CC}	4.5	5	5.5	4.75	5	5.25	V
High-level output current, I_{OH}			-800			-800	μ A
Low-level output current, I_{OL}			16			16	mA
Clock frequency, f_{clock}	0		25	0		25	MHz
Width of clock or clear pulse, t_w	20			20			ns
Setup time, t_{su}	Data input			20			ns
	Clear inactive-state			25			ns
Data hold time, t_h	5			5			ns
Operating free-air temperature, T_A	-55		125	0		70	°C

electrical characteristics over recommended operating free-air temperature range (unless otherwise noted)

PARAMETER	TEST CONDITIONS†	MIN	TYP‡	MAX	UNIT
V_{IH} High-level input voltage		2			V
V_{IL} Low-level input voltage				0.8	V
V_{IK} Input clamp voltage	$V_{CC} = \text{MIN}$, $I_I = -12 \text{ mA}$			-1.5	V
V_{OH} High-level output voltage	$V_{CC} = \text{MIN}$, $V_{IH} = 2 \text{ V}$, $V_{IL} = 0.8 \text{ V}$, $I_{OH} = -800 \mu\text{A}$	2.4	3.4		V
V_{OL} Low-level output voltage	$V_{CC} = \text{MIN}$, $V_{IH} = 2 \text{ V}$, $V_{IL} = 0.8 \text{ V}$, $I_{OL} = 16 \text{ mA}$		0.2	0.4	V
I_I Input current at maximum input voltage	$V_{CC} = \text{MAX}$, $V_I = 5.5 \text{ V}$			1	mA
I_{IH} High-level input current	$V_{CC} = \text{MAX}$, $V_I = 2.4 \text{ V}$			40	μ A
I_{IL} Low-level input current	$V_{CC} = \text{MAX}$, $V_I = 0.4 \text{ V}$			-1.6	mA
I_{OS} Short-circuit output current§	$V_{CC} = \text{MAX}$	SN54'	-20	-57	mA
		SN74'	-18	-57	
I_{CC} Supply current	$V_{CC} = \text{MAX}$, See Note 2	'174	45	65	mA
		'175	30	45	

† For conditions shown as MIN or MAX, use the appropriate value specified under recommended operating conditions for the applicable device type.

‡ All typical values are at $V_{CC} = 5 \text{ V}$, $T_A = 25^\circ\text{C}$.

§ Not more than one output should be shorted at a time.

NOTE 2: With all outputs open and 4.5 V applied to all data and clear inputs, I_{CC} is measured after a momentary ground, then 4.5 V, is applied to clock.

switching characteristics, $V_{CC} = 5 \text{ V}$, $T_A = 25^\circ\text{C}$

PARAMETER	TEST CONDITIONS	MIN	TYP	MAX	UNIT
f_{max} Maximum clock frequency		25	35		MHz
t_{PLH} Propagation delay time, low-to-high-level output from clear (SN54175, SN74175 only)	$C_L = 15 \text{ pF}$, $R_L = 400 \Omega$, See Note 3		16	25	ns
t_{PHL} Propagation delay time, high-to-low-level output from clear			23	35	ns
t_{PLH} Propagation delay time, low-to-high-level output from clock			20	30	ns
t_{PHL} Propagation delay time, high-to-low-level output from clock			24	35	ns

NOTE 3: Load circuits and voltage waveforms are shown in Section 1.

TEXAS
INSTRUMENTS

POST OFFICE BOX 655012 • DALLAS, TEXAS 75265

SN54LS174, SN54LS175, SN74LS174, SN74LS175 HEX/QUADRUPLE D-TYPE FLIP-FLOPS WITH CLEAR

absolute maximum ratings over operating free-air temperature range (unless otherwise noted)

Supply voltage, V_{CC} (see Note 1)	7 V
Input voltage	7 V
Operating free-air temperature range: SN54LS174, SN54LS175 Circuits	-55°C to 125°C
SN74LS174, SN74LS175 Circuits	0°C to 70°C
Storage temperature range	-65°C to 150°C

NOTE 1: Voltage values are with respect to network ground terminal.

recommended operating conditions

	SN54LS174			SN74LS174			UNIT
	SN54LS175			SN74LS175			
	MIN	NOM	MAX	MIN	NOM	MAX	
Supply voltage, V_{CC}	4.5	5	5.5	4.75	5	5.25	V
High-level output current, I_{OH}			-400			-400	μ A
Low-level output current, I_{OL}			4			8	mA
Clock frequency, f_{clock}	0		30	0		30	MHz
Width of clock or clear pulse, t_W	20			20			ns
Setup time, t_{SU}	Data input	20		20			ns
	Clear inactive-state	25		25			ns
Data hold time, t_H	5			5			ns
Operating free-air temperature, T_A	-55		125	0		70	°C

electrical characteristics over recommended operating free-air temperature range (unless otherwise noted)

PARAMETER	TEST CONDITIONS†	SN54LS174			SN74LS174			UNIT
		SN54LS175			SN74LS175			
		MIN	TYP‡	MAX	MIN	TYP‡	MAX	
V_{IH} High-level input voltage		2			2			V
V_{IL} Low-level input voltage				0.7			0.8	V
V_{IK} Input clamp voltage	$V_{CC} = \text{MIN}, I_I = -18 \text{ mA}$			-1.5			-1.5	V
V_{OH} High-level output voltage	$V_{CC} = \text{MIN}, V_{IH} = 2 \text{ V}, V_{IL} = V_{IL \text{ max}}, I_{OH} = -400 \mu\text{A}$	2.5	3.5		2.7	3.5		V
V_{OL} Low-level output voltage	$V_{CC} = \text{MIN}, V_{IH} = 2 \text{ V}, V_{IL} = V_{IL \text{ max}}$	$I_{OL} = 4 \text{ mA}$	0.25	0.4	0.25	0.4		V
		$I_{OL} = 8 \text{ mA}$			0.35	0.5		
I_I Input current at maximum input voltage	$V_{CC} = \text{MAX}, V_I = 7 \text{ V}$			0.1			0.1	mA
I_{IH} High-level input current	$V_{CC} = \text{MAX}, V_I = 2.7 \text{ V}$			20			20	μ A
I_{IL} Low-level input current	$V_{CC} = \text{MAX}, V_I = 0.4 \text{ V}$			-0.4			-0.4	mA
I_{OS} Short-circuit output current §	$V_{CC} = \text{MAX}$	-20		-100	-20		-100	mA
I_{CC} Supply current	$V_{CC} = \text{MAX},$ See Note 2	'LS174	16	26	16	26		mA
		'LS175	11	18	11	18		

† For conditions shown as MIN or MAX, use the appropriate value specified under recommended operating conditions.

‡ All typical values are at $V_{CC} = 5 \text{ V}, T_A = 25^\circ\text{C}$.

§ Not more than one output should be shorted at a time, and duration of the short-circuit should not exceed one second.

NOTE 2: With all outputs open and 4.5 V applied to all data and clear inputs, I_{CC} is measured after a momentary ground, then 4.5 V, is applied to clock.

switching characteristics, $V_{CC} = 5 \text{ V}, T_A = 25^\circ\text{C}$

PARAMETER	TEST CONDITIONS	'LS174			'LS175			UNIT
		MIN	TYP	MAX	MIN	TYP	MAX	
f_{max} Maximum clock frequency	$C_L = 15 \text{ pF}, R_L = 2 \text{ k}\Omega,$ See Note 3	30	40		30	40		MHz
t_{PLH} Propagation delay time, low-to-high-level output from clear					20	30		ns
t_{PHL} Propagation delay time, high-to-low-level output from clear			23	35	20	30		ns
t_{PLH} Propagation delay time, low-to-high-level output from clock			20	30	13	25		ns
t_{PHL} Propagation delay time, high-to-low-level output from clock			21	30	16	25		ns

NOTE 3: Load circuits and voltage waveforms are shown in Section 1.



POST OFFICE BOX 655012 • DALLAS, TEXAS 75265

SN54S174, SN54S175, SN74S174, SN74S175 HEX/QUADRUPLE D-TYPE FLIP-FLOPS WITH CLEAR

absolute maximum ratings over operating free-air temperature range (unless otherwise noted)

Supply voltage, V_{CC} (see Note 1)	7 V
Input voltage	5.5 V
Operating free-air temperature range: SN54S174, SN54S175 Circuits	-55°C to 125°C
SN74S174, SN74S175 Circuits	0°C to 70°C
Storage temperature range	-65°C to 150°C

NOTE 1: Voltage values are with respect to network ground terminal.

recommended operating conditions

	SN54S174, SN54S175			SN74S174, SN74S175			UNIT		
	MIN	NOM	MAX	MIN	NOM	MAX			
Supply voltage, V_{CC}	4.5	5	5.5	4.75	5	5.25	V		
High-level output current, I_{OH}			-1			-1	mA		
Low-level output current, I_{OL}			20			20	mA		
Clock frequency, f_{clock}			75			75	MHz		
Pulse width, t_w	Clock			7			ns		
	Clear			10					
Setup time, t_{SU}	Data input			5			ns		
	Clear inactive-state			5					
Data hold time, t_H	3			3			ns		
Operating free-air temperature, T_A	-55			125			0	70	°C

electrical characteristics over recommended operating free-air temperature range (unless otherwise noted)

PARAMETER	TEST CONDITIONS†	MIN	TYP‡	MAX	UNIT
V_{IH} High-level input voltage		2			V
V_{IL} Low-level input voltage				0.8	V
V_{IK} Input clamp voltage	$V_{CC} = \text{MIN}, I_I = -18 \text{ mA}$			-1.2	V
V_{OH} High-level output voltage	$V_{CC} = \text{MIN}, V_{IH} = 2 \text{ V},$ $V_{IL} = 0.8 \text{ V}, I_{OH} = -1 \text{ mA}$	SN54S'	2.5	3.4	V
		SN74S'	2.7	3.4	
V_{OL} Low-level output voltage	$V_{CC} = \text{MIN}, V_{IH} = 2 \text{ V},$ $V_{IL} = 0.8 \text{ V}, I_{OL} = 20 \text{ mA}$			0.5	V
I_I Input current at maximum input voltage	$V_{CC} = \text{MAX}, V_I = 5.5 \text{ V}$			1	mA
I_{IH} High-level input current	$V_{CC} = \text{MAX}, V_I = 2.7 \text{ V}$			50	µA
I_{IL} Low-level input current	$V_{CC} = \text{MAX}, V_I = 0.5 \text{ V}$			-2	mA
I_{OS} Short-circuit output current§	$V_{CC} = \text{MAX}$	-40		-100	mA
I_{CC} Supply current	$V_{CC} = \text{MAX}, \text{ See Note 2}$	'174	90	144	mA
		'175	60	96	

†For conditions shown as MIN or MAX, use the appropriate value specified under recommended operating conditions for the applicable device type.

‡All typical values are at $V_{CC} = 5 \text{ V}, T_A = 25^\circ\text{C}$.

§Not more than one output should be shorted at a time, and duration of the short-circuit should not exceed one second.

NOTE 2: With all outputs open and 4.5 V applied to all data and clear inputs, I_{CC} is measured after a momentary ground, then 4.5 V, is applied to clock.

switching characteristics, $V_{CC} = 5 \text{ V}, T_A = 25^\circ\text{C}$

PARAMETER	TEST CONDITIONS	MIN	TYP	MAX	UNIT
f_{max} Maximum clock frequency		75	110		MHz
t_{PLH} Propagation delay time, low-to-high-level \bar{Q} output from clear (SN54S175, SN74S175 only)	$C_L = 15 \text{ pF},$ $R_L = 280 \Omega,$ See Note 3		10	15	ns
t_{PHL} Propagation delay time, high-to-low-level Q output from clear			13	22	ns
t_{PLH} Propagation delay time, low-to-high-level output from clock			8	12	ns
t_{PHL} Propagation time, high-to-low-level output from clock			11.5	17	ns

NOTE 3: Load circuits and voltage waveforms are shown in Section 1.



IMPORTANT NOTICE

Texas Instruments (TI) reserves the right to make changes to its products or to discontinue any semiconductor product or service without notice, and advises its customers to obtain the latest version of relevant information to verify, before placing orders, that the information being relied on is current.

TI warrants performance of its semiconductor products and related software to the specifications applicable at the time of sale in accordance with TI's standard warranty. Testing and other quality control techniques are utilized to the extent TI deems necessary to support this warranty. Specific testing of all parameters of each device is not necessarily performed, except those mandated by government requirements.

Certain applications using semiconductor products may involve potential risks of death, personal injury, or severe property or environmental damage ("Critical Applications").

TI SEMICONDUCTOR PRODUCTS ARE NOT DESIGNED, INTENDED, AUTHORIZED, OR WARRANTED TO BE SUITABLE FOR USE IN LIFE-SUPPORT APPLICATIONS, DEVICES OR SYSTEMS OR OTHER CRITICAL APPLICATIONS.

Inclusion of TI products in such applications is understood to be fully at the risk of the customer. Use of TI products in such applications requires the written approval of an appropriate TI officer. Questions concerning potential risk applications should be directed to TI through a local SC sales office.

In order to minimize risks associated with the customer's applications, adequate design and operating safeguards should be provided by the customer to minimize inherent or procedural hazards.

TI assumes no liability for applications assistance, customer product design, software performance, or infringement of patents or services described herein. Nor does TI warrant or represent that any license, either express or implied, is granted under any patent right, copyright, mask work right, or other intellectual property right of TI covering or relating to any combination, machine, or process in which such semiconductor products or services might be or are used.

IMPORTANT NOTICE

Texas Instruments and its subsidiaries (TI) reserve the right to make changes to their products or to discontinue any product or service without notice, and advise customers to obtain the latest version of relevant information to verify, before placing orders, that information being relied on is current and complete. All products are sold subject to the terms and conditions of sale supplied at the time of order acknowledgement, including those pertaining to warranty, patent infringement, and limitation of liability.

TI warrants performance of its semiconductor products to the specifications applicable at the time of sale in accordance with TI's standard warranty. Testing and other quality control techniques are utilized to the extent TI deems necessary to support this warranty. Specific testing of all parameters of each device is not necessarily performed, except those mandated by government requirements.

CERTAIN APPLICATIONS USING SEMICONDUCTOR PRODUCTS MAY INVOLVE POTENTIAL RISKS OF DEATH, PERSONAL INJURY, OR SEVERE PROPERTY OR ENVIRONMENTAL DAMAGE ("CRITICAL APPLICATIONS"). TI SEMICONDUCTOR PRODUCTS ARE NOT DESIGNED, AUTHORIZED, OR WARRANTED TO BE SUITABLE FOR USE IN LIFE-SUPPORT DEVICES OR SYSTEMS OR OTHER CRITICAL APPLICATIONS. INCLUSION OF TI PRODUCTS IN SUCH APPLICATIONS IS UNDERSTOOD TO BE FULLY AT THE CUSTOMER'S RISK.

In order to minimize risks associated with the customer's applications, adequate design and operating safeguards must be provided by the customer to minimize inherent or procedural hazards.

TI assumes no liability for applications assistance or customer product design. TI does not warrant or represent that any license, either express or implied, is granted under any patent right, copyright, mask work right, or other intellectual property right of TI covering or relating to any combination, machine, or process in which such semiconductor products or services might be or are used. TI's publication of information regarding any third party's products or services does not constitute TI's approval, warranty or endorsement thereof.

Advanced Search[TI Home](#)[TI_ME](#)[Employment](#)[Tech Support](#)[Comments](#)[Site Map](#)[TI Global](#)[>> Semiconductor Home](#) > [Products](#) > [Digital Logic](#) > [Flip-Flops](#) > [D-Type Flip-Flops](#) >

SN54LS174, Hex D-type Flip-Flops With Clear

Device Status: Active

- > [Description](#)
- > [Features](#)
- > [Datasheets](#)
- > [Pricing/Samples/Availability](#)
- > [Application Notes](#)
- > [Related Documents](#)
- > [Training](#)

Parameter Name	SN54LS174
Voltage Nodes (V)	5
Vcc range (V)	4.5 to 5.5
Input Level	TTL
Output Level	TTL
Output	2S
No. of Bits	6

Description

These monolithic, positive-edge-triggered flip-flops utilize TTL circuitry to implement D-type flip-flop logic. All have a direct clear input, and the '175, 'LS175, and 'S175 feature complementary outputs from each flip-flop.

Information at the D inputs meeting the setup time requirements is transferred to the Q outputs on the positive-going edge of the clock pulse. Clock triggering occurs at a particular voltage level and is not directly related to the transition time of the positive-going pulse. When the clock input is at either the high or low level, the D input signal has no effect at the output.

These circuits are fully compatible for use with most TTL circuits.

Features

'174, 'LS174, 'S174 ... HEX D-TYPE FLIP-FLOPS

'175, 'LS175, 'S175 ... QUADRUPLE D-TYPE FLIP-FLOPS

- '174, 'LS174, 'S174 Contain Six Flip-Flops with Single-Rail Outputs
- '175, 'LS175, 'S175 Contain Four Flip-Flops with Double-Rail Outputs
- Three Performance Ranges Offered: See Table Lower Right
- Buffered Clock and Direct Clear Inputs
- Individual Data Input to Each Flip-Flop
- Applications include:
 - Buffer/Storage Registers
 - Shift Registers
 - Pattern Generators

To view the following documents, [Acrobat Reader 3.x](#) is required.

To download a document to your hard drive, right-click on the link and choose 'Save'.

Datasheets

Full datasheet in Acrobat PDF: [sdls068.pdf](#) (352 KB)

Full datasheet in Zipped PostScript: [sdls068.psz](#) (394 KB)

Pricing/Samples/Availability

<u>Orderable Device</u>	<u>Package</u>	<u>Pins</u>	<u>Temp (°C)</u>	<u>Status</u>	<u>Price/unit USD (100-999)</u>	<u>Pack Qty</u>	<u>DSCC Number</u>	<u>Availability / Samples</u>
JM38510/30106B2A	<u>FK</u>	20	-55 TO 125	ACTIVE	9.85	1		Check stock or order
JM38510/30106BEA	<u>J</u>	16	-55 TO 125	ACTIVE	3.17	1		Check stock or order
JM38510/30106BFA	<u>W</u>	16	-55 TO 125	ACTIVE	9.85	1		Check stock or order
SN54LS174J	<u>J</u>	16	-55 TO 125	ACTIVE	1.39	1		Check stock or order
SNJ54LS174FK	<u>FK</u>	20	-55 TO 125	ACTIVE	8.82	1		Check stock or order

SNJ54LS174J	<u>J</u>	16	-55 TO 125	ACTIVE	1.92	1	Check stock or order
SNJ54LS174W	<u>W</u>	16	-55 TO 125	ACTIVE	8.82	1	Check stock or order

Application Reports

View Application Reports for [Digital Logic](#)

- [Designing With Logic](#) (SDYA009C - Updated: 06/01/1997)
- [Designing with the SN54/74LS123](#) (SDLA006A - Updated: 03/01/1997)
- [Input And Output Characteristics Of Digital Integrated Circuits](#) (SDYA010 - Updated: 10/01/1996)
- [Live Insertion](#) (SDYA012 - Updated: 10/01/1996)

Related Documents

- [Documentation Rules \(SAP\) And Ordering Information](#) (SZZU001B, 4 KB - Updated: 05/06/1999)
- [Logic Selection Guide Second Half 2000](#) (SDYU001N, 5035 KB - Updated: 04/17/2000)
- [MicroStar Junior BGA Design Summary](#) (SCET004, 284 KB - Updated: 07/28/2000)
- [More Power In Less Space - Technical Article](#) (SCAU001A, 850 KB - Updated: 03/01/1996)

Table Data Updated on: 9/7/2000

>> [Semiconductor Home](#) > [Products](#) > [Digital Logic](#) > [Flip-Flops](#) > [D-Type Flip-Flops](#) >

SN54LS175, Quadruple D-type Flip-Flops With Clear

Device Status: Active

- > [Description](#)
- > [Features](#)
- > [Datasheets](#)
- > [Pricing/Samples/Availability](#)
- > [Application Notes](#)
- > [Related Documents](#)
- > [Training](#)

Parameter Name	SN54LS175
Voltage Nodes (V)	5
Vcc range (V)	4.5 to 5.5
Input Level	TTL
Output Level	TTL
Output	2S
No. of Bits	4

Description

These monolithic, positive-edge-triggered flip-flops utilize TTL circuitry to implement D-type flip-flop logic. All have a direct clear input, and the '175, 'LS175, and 'S175 feature complementary outputs from each flip-flop.

Information at the D inputs meeting the setup time requirements is transferred to the Q outputs on the positive-going edge of the clock pulse. Clock triggering occurs at a particular voltage level and is not directly related to the transition time of the positive-going pulse. When the clock input is at either the high or low level, the D input signal has no effect at the output.

These circuits are fully compatible for use with most TTL circuits.

Features

'174, 'LS174, 'S174 ... HEX D-TYPE FLIP-FLOPS

'175, 'LS175, 'S175 ... QUADRUPLE D-TYPE FLIP-FLOPS

- '174, 'LS174, 'S174 Contain Six Flip-Flops with Single-Rail Outputs
- '175, 'LS175, 'S175 Contain Four Flip-Flops with Double-Rail Outputs
- Three Performance Ranges Offered: See Table Lower Right
- Buffered Clock and Direct Clear Inputs
- Individual Data Input to Each Flip-Flop
- Applications include:
 - Buffer/Storage Registers
 - Shift Registers
 - Pattern Generators

To view the following documents, [Acrobat Reader 3.x](#) is required.

To download a document to your hard drive, right-click on the link and choose 'Save'.

Datasheets

Full datasheet in Acrobat PDF: [sdls068.pdf](#) (352 KB)

Full datasheet in Zipped PostScript: [sdls068.psz](#) (394 KB)

Pricing/Samples/Availability

<u>Orderable Device</u>	<u>Package</u>	<u>Pins</u>	<u>Temp (°C)</u>	<u>Status</u>	<u>Price/unit USD (100-999)</u>	<u>Pack Qty</u>	<u>DSCC Number</u>	<u>Availability / Samples</u>
JM38510/30107B2A	<u>FK</u>	20	-55 TO 125	ACTIVE	9.85	1		Check stock or order
JM38510/30107BEA	<u>J</u>	16	-55 TO 125	ACTIVE	3.17	1		Check stock or order
JM38510/30107BFA	<u>W</u>	16	-55 TO 125	ACTIVE	9.85	1		Check stock or order
SN54LS175J	<u>J</u>	16	-55 TO 125	ACTIVE	1.39	1		Check stock or order
SNJ54LS175FK	<u>FK</u>	20	-55 TO 125	ACTIVE	8.82	1		Check stock or order

SNJ54LS175J	<u>J</u>	16	-55 TO 125	ACTIVE	1.92	1	Check stock or order
SNJ54LS175W	<u>W</u>	16	-55 TO 125	ACTIVE	8.82	1	Check stock or order

Application Reports

View Application Reports for [Digital Logic](#)

- [Designing With Logic](#) (SDYA009C - Updated: 06/01/1997)
- [Designing with the SN54/74LS123](#) (SDLA006A - Updated: 03/01/1997)
- [Input And Output Characteristics Of Digital Integrated Circuits](#) (SDYA010 - Updated: 10/01/1996)
- [Live Insertion](#) (SDYA012 - Updated: 10/01/1996)

Related Documents

- [Documentation Rules \(SAP\) And Ordering Information](#) (SZZU001B, 4 KB - Updated: 05/06/1999)
- [Logic Selection Guide Second Half 2000](#) (SDYU001N, 5035 KB - Updated: 04/17/2000)
- [MicroStar Junior BGA Design Summary](#) (SCET004, 284 KB - Updated: 07/28/2000)
- [More Power In Less Space - Technical Article](#) (SCAU001A, 850 KB - Updated: 03/01/1996)

Table Data Updated on: 9/7/2000