

# Kingbright Electronic Co., Ltd.



Mail Address : P. O. Box 81-153 Taipei, Taiwan  
 Telex No. : 22249 TWNKIN

Cable Address: "TWNKIN" Taipei  
 Telephones : 715-2848 • 713-0682

2.5x7mm RECTUGULAR LED LAMP

L-353

Unit: mm

Tolerance: ±0.2

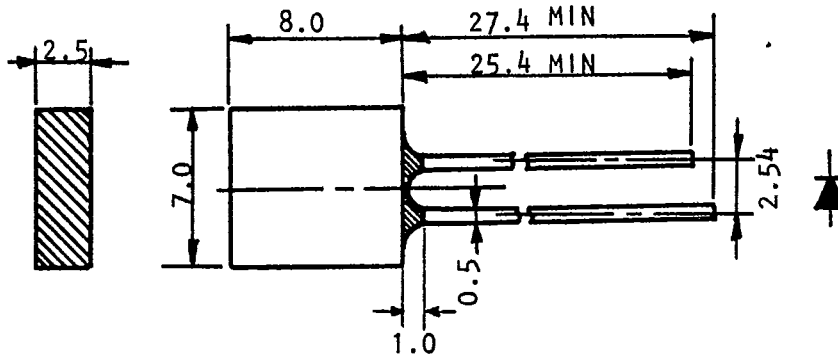

✓ - New

**SELECTION GUIDE**

PART NO.	SOURCE (DICE)	LENSE TYPE (RESIN)	AXIAL LUMINOUS INTENSITY IN MCD @ 20mA		VIEWING ANGLE
			MIN	TYP	
✓ L-353RD	RED (GaAsP)	Red Diffused	0.16	0.22	100°
✓ L-353RDT		Red Top Diffused	0.28	0.39	100°
✓ L-353GD	GREEN (GaP)	Green Diffused	1.37	2.77	100°
✓ L-353GDT		Green Top Diff.	2.18	4.15	100°
✓ L-353YD	YELLOW (GaAsP/GaP)	Yellow Diffused	5.49	7.91	100°
✓ L-353YDT		Yellow Top Diff.	8.72	12.28	100°
✓ L-353ID	IMPROVED	Red Diffused	1.56	2.22	100°
✓ L-353IDT	RED (GaAsP/GaP)	Red Top Diffused	2.32	3.80	100°