

Universal Standard 78 Series Regulators



3-Terminal Positive Voltage Regulator

BA78□□,BA78M□□Series

●Description

BA78□□, BA78M□□ series are three-terminal regulators available with several fixed output voltages. It supplies the stable fixed voltage from unstable direct input voltage. The useful output voltage lineup is 5V, 6V, 7V, 8V, 9V, 10V, 12V, 15V, 18V, 20V, 24V with 0.5A / 1A current ability. They have nearly same electric characteristics as competitor products and cover a wide range of application.

●Features

- 1) Built-in over-current protection circuit and thermal shutdown circuit
- 2) High ripple rejection
- 3) Available TO220CP-3, TO252-3 package to a wide range application
- 4) Compatible replacement to competitor products
- 5) Various voltage lineup (5V, 6V, 7V, 8V, 9V, 10V, 12V, 15V, 18V, 20V, 24V)

●Applications

Fixed voltage power supply for TV, Audio components, etc

●Line up

■1A BA78□□Series

Part Number	5V	6V	7V	8V	9V	10V	12V	15V	18V	20V	24V	Package
BA78□□CP	○	○	○	○	○	○	○	○	○	○	○	TO220CP-3
BA78□□FP	○	○	○	○	○	○	○	○	○	○	○	TO252-3

■0.5A BA78M□□Series

Part Number	5V	6V	7V	8V	9V	10V	12V	15V	18V	20V	24V	Package
BA78M□□CP	○	○	○	○	○	○	○	○	○	○	○	TO220CP-3
BA78M□□FP	○	○	○	○	○	○	○	○	○	○	○	TO252-3

●Output Voltage and Marking

Part Number : BA78□□□□ (1A)
 $\frac{\quad}{a} \frac{\quad}{b}$

Part Number : BA78M□□□□ (0.5A)
 $\frac{\quad}{a} \frac{\quad}{b}$

Symbol	assignment of output voltage			
a	□□	Output voltage (V)	□□	Output voltage (V)
	05	5.0V typ.	12	12V typ.
	06	6.0V typ.	15	15V typ.
	07	7.0V typ.	18	18V typ.
	08	8.0V typ.	20	20V typ.
	09	9.0V typ.	24	24V typ.
	10	10.0V typ.		
b	Package CP : TO220CP-3 FP : TO252-3			

Symbol	assignment of output voltage			
a	□□	Output voltage (V)	□□	Output voltage (V)
	05	5.0V typ.	12	12V typ.
	06	6.0V typ.	15	15V typ.
	07	7.0V typ.	18	18V typ.
	08	8.0V typ.	20	20V typ.
	09	9.0V typ.	24	24V typ.
	10	10.0V typ.		
b	Package CP : TO220CP-3 FP : TO252-3			

●Absolute Maximum Rating (Ta=25°C)

BA78□□CP/FP, BA78M□□CP/FP

Parameter	Symbol	Limits	Unit
Power supply voltage	Vin	35	V
Power Dissipation 1	Pd1	2 *1	W
		1 *1	
Power Dissipation 2	Pd2	22 *2	W
		10 *2	
Output Current	Io	1 *3	A
		0.5 *3	
Operating Temperature Range	Topr	-40~+85	°C
Storage Temperature Range	Tstg	-55~+150	°C
Operating Junction Temperature Range	Tj	-40~+150	°C

*1 Derating in done 16mW/°C(TO220CP-3), 8mW/°C(TO252-3) for temperatures above Ta=25°C

*2 Derating in done 176mW/°C(TO220CP-3), 80mW/°C(TO252-3) for temperatures above Ta=25°C, Mounted on infinity Aluminium heat sink.

*3 Pd,ASO and Tjmax(150°C) should not be exceeded.

●Operating Conditions(Ta=25°C, Pd should not be exceeded)

BA78□□CP/FP

Parameter	Symbol	Min.	Max.	Unit.	
Input Voltage	Vin	BA7805	7.5	25	V
		BA7806	8.5	21	
		BA7807	9.5	22	
		BA7808	10.5	23	
		BA7809	11.5	26	
		BA7810	12.5	25	
		BA7812	14.5	27	
		BA7815	17.5	30	
		BA7818	21	33	
		BA7820	23	33	
		BA7824	27	33	
Output Current	Io	-	1	A	

BA78M□□CP/FP

Parameter	Symbol	Min.	Max.	Unit.	
Input Voltage	Vin	BA78M05	7.5	25	V
		BA78M06	8.5	21	
		BA78M07	9.5	22	
		BA78M08	10.5	23	
		BA78M09	11.5	26	
		BA78M10	12.5	25	
		BA78M12	14.5	27	
		BA78M15	17.5	30	
		BA78M18	21	33	
		BA78M20	23	33	
		BA78M24	27	33	
Output Current	Io	-	0.5	A	

●BA78M□□CP/FP

ELECTRICAL CHARACTERISTICS

(Ta=25°C, Vin=10V(05), 11V(06), 13V(07), 14V(08), 15V(09), 16V(10), 19V(12), 23V(15), 27V(18), 29V(20), 33V(24),
Io=350mA unless otherwise specified)

Parameter	Symbol	Type	Limit			Unit	Condition
			Min	Typ	Max		
Output Voltage 1	Vo1	05	4.8	5.0	5.2	V	Io=350mA
		06	5.75	6.0	6.25		
		07	6.7	7.0	7.3		
		08	7.7	8.0	8.3		
		09	8.6	9.0	9.4		
		10	9.6	10.0	10.4		
		12	11.5	12.0	12.5		
		15	14.4	15.0	15.6		
		18	17.3	18.0	18.7		
		20	19.2	20.0	20.8		
		24	23.0	24.0	25.0		
Output Voltage 2	Vo2	05	4.75	—	5.25	V	Vin=7.5~20V, Io=5mA~350mA
		06	5.7	—	6.3		Vin=8.5~21V, Io=5mA~350mA
		07	6.65	—	7.35		Vin=9.5~22V, Io=5mA~350mA
		08	7.6	—	8.4		Vin=10.5~23V, Io=5mA~350mA
		09	8.55	—	9.45		Vin=11.5~24V, Io=5mA~350mA
		10	9.5	—	10.5		Vin=12.5~25V, Io=5mA~350mA
		12	11.4	—	12.6		Vin=15~27V, Io=5mA~350mA
		15	14.25	—	15.75		Vin=17.5~30V, Io=5mA~350mA
		18	17.1	—	18.9		Vin=21~33V, Io=5mA~350mA
		20	19.0	—	21.0		Vin=23~33V, Io=5mA~350mA
		24	22.8	—	25.2	Vin=27~33V, Io=5mA~350mA	
Line Regulation 1	Reg.I1	05	—	3	100	mV	Vin=7~25V, Io=200mA
		06	—	3	100		Vin=8~25V, Io=200mA
		07	—	4	100		Vin=9~25V, Io=200mA
		08	—	4	100		Vin=10.5~25V, Io=200mA
		09	—	4	100		Vin=11.5~26V, Io=200mA
		10	—	5	100		Vin=12.5~28V, Io=200mA
		12	—	5	100		Vin=14.5~30V, Io=200mA
		15	—	6	100		Vin=17.5~30V, Io=200mA
		18	—	7	100		Vin=21~33V, Io=200mA
		20	—	8	100		Vin=23~33V, Io=200mA
		24	—	10	100	Vin=27~33V, Io=200mA	
Line Regulation 2	Reg.I2	05	—	1	50	mV	Vin=8~12V, Io=200mA
		06	—	1	50		Vin=9~25V, Io=200mA
		07	—	1	50		Vin=10~25V, Io=200mA
		08	—	1	50		Vin=11~25V, Io=200mA
		09	—	2	50		Vin=12~25V, Io=200mA
		10	—	2	50		Vin=14~26V, Io=200mA
		12	—	3	50		Vin=16~30V, Io=200mA
		15	—	3	50		Vin=20~30V, Io=200mA
		18	—	3	50		Vin=24~33V, Io=200mA
		20	—	4	50		Vin=24~33V, Io=200mA
		24	—	5	50	Vin=28~33V, Io=200mA	
Ripple Rejection	R.R.	05	62	78	—	dB	ein=1Vrms, f=120Hz, Io=100mA
		06	60	74	—		
		07	57	71	—		
		08	56	69	—		
		09	56	67	—		
		10	56	66	—		
		12	55	63	—		
		15	54	60	—		
		18	53	58	—		
		20	53	58	—		
		24	50	55	—		
Temperature Coefficient of Output Voltage	Tcvo	05	—	-1.0	—	mV/°C	Io=5mA, Tj=0~125°C
		06/07/08/09/10/12	—	-0.5	—		
		15/18	—	-0.6	—		
		20/24	—	-0.7	—		
Peak Output Current	Io-p	common	—	875	—	mA	Tj=25°C
Dropout Voltage	Vd	common	—	2.0	—	V	Io=500mA

●BA78M□□CP/FP

ELECTRICAL CHARACTERISTICS

(Ta=25°C, Vin=10V(05), 11V(06), 13V(07), 14V(08), 15V(09), 16V(10), 19V(12), 23V(15), 27V(18), 29V(20), 33V(24),
Io=350mA unless otherwise specified)

Parameter	Symbol	Type	Limit			Unit	Condition
			Min	Typ	Max		
Load Regulation 1	Reg.L1	05	—	20	100	mV	Io=5mA~500mA
		06	—	20	120		
		07	—	20	140		
		08	—	20	160		
		09	—	20	180		
		10	—	20	200		
		12	—	20	240		
		15	—	20	300		
		18	—	20	360		
		20	—	20	400		
Load Regulation 2	Reg.L2	05	—	10	50	mV	Io=5mA~200mA
		06	—	10	60		
		07	—	10	70		
		08	—	10	80		
		09	—	10	90		
		10	—	10	100		
		12	—	10	120		
		15	—	10	150		
		18	—	10	180		
		20	—	10	200		
Output Noise Voltage	Vn	05	—	40	—	μV	f=10Hz~100kHz
		06	—	60	—		
		07	—	70	—		
		08	—	80	—		
		09	—	90	—		
		10	—	100	—		
		12	—	110	—		
		15	—	130	—		
		18	—	140	—		
		20	—	150	—		
Bias Current	Ib	common	—	4.5	6.0	mA	Io=0mA
Bias Current Change1	Ib1	common	—	—	0.5	mA	Io=5mA~350mA
Bias Current Change 2	Ib2	05	—	—	0.8	mA	Vin:8~25V, Io=200mA
		06	—	—	0.8		Vin:9~25V, Io=200mA
		07	—	—	0.8		Vin:10~25V, Io=200mA
		08	—	—	0.8		Vin:10.5~25V, Io=200mA
		09	—	—	0.8		Vin:12~25V, Io=200mA
		10	—	—	0.8		Vin:13~25V, Io=200mA
		12	—	—	0.8		Vin:14.5~30V, Io=200mA
		15	—	—	0.8		Vin:17.5~30V, Io=200mA
		18	—	—	0.8		Vin:21~33V, Io=200mA
		20	—	—	0.8		Vin:23~33V, Io=200mA
Short-Circuit Output Current	Ios	05/06/07/08	—	0.4	—	A	Vin=25V
		09/10/12/15/18/20/24	—	0.17	—		Vin=30V
Output Resistance	Ro	05	—	9	—	mΩ	f=1kHz
		06	—	10	—		
		07	—	11	—		
		08	—	12	—		
		09	—	13	—		
		10	—	14	—		
		12	—	16	—		
		15	—	19	—		
		18	—	22	—		
		20	—	25	—		
24	—	37	—				

●BA78□□CP/FP

ELECTRICAL CHARACTERISTICS

(Ta=25°C, Vin=10V(05), 11V(06), 13V(07), 14V(08), 15V(09), 16V(10), 19V(12), 23V(15), 27V(18), 29V(20), 33V(24),
Io=500mA unless otherwise specified)

Parameter	Symbol	Type	Limit			Unit	Condition		
			Min	Typ	Max				
Output Voltage 1	Vo1	05	4.8	5.0	5.2	V	Io=500mA		
		06	5.75	6.0	6.25				
		07	6.7	7.0	7.3				
		08	7.7	8.0	8.3				
		09	8.6	9.0	9.4				
		10	9.6	10.0	10.4				
		12	11.5	12.0	12.5				
		15	14.4	15.0	15.6				
		18	17.3	18.0	18.7				
Output Voltage 2	Vo2	20	19.2	20.0	20.8	V	Io=500mA		
		24	23.0	24.0	25.0				
		05	4.75	—	5.25			V	Vin=7.5~20V, Io=5mA~1A
		06	5.7	—	6.3				Vin=8.5~21V, Io=5mA~1A
		07	6.65	—	7.35				Vin=9.5~22V, Io=5mA~1A
		08	7.6	—	8.4				Vin=10.5~23V, Io=5mA~1A
		09	8.55	—	9.45				Vin=11.5~26V, Io=5mA~1A
		10	9.5	—	10.5				Vin=12.5~25V, Io=5mA~1A
		12	11.4	—	12.6				Vin=15~27V, Io=5mA~1A
15	14.25	—	15.75	Vin=17.5~30V, Io=5mA~1A					
18	17.1	—	18.9	Vin=21~33V, Io=5mA~1A					
20	19.0	—	21.0	Vin=23~33V, Io=5mA~1A					
24	22.8	—	25.2	Vin=27~33V, Io=5mA~1A					
Line Regulation 1	Reg.I1	05	—	3	100	mV	Vin=7~25V, Io=500mA		
		06	—	4	120		Vin=8~25V, Io=500mA		
		07	—	5	140		Vin=9~25V, Io=500mA		
		08	—	5	160		Vin=10.5~25V, Io=500mA		
		09	—	6	180		Vin=11.5~26V, Io=500mA		
		10	—	7	200		Vin=12.5~27V, Io=500mA		
		12	—	8	240		Vin=14.5~30V, Io=500mA		
		15	—	9	300		Vin=17.5~30V, Io=500mA		
		18	—	10	360		Vin=21~33V, Io=500mA		
Line Regulation 2	Reg.I2	20	—	12	400	mV	Vin=23~33V, Io=500mA		
		24	—	15	480		Vin=27~33V, Io=500mA		
		05	—	1	50		Vin=8~12V, Io=500mA		
		06	—	2	60		Vin=9~13V, Io=500mA		
		07	—	2	70		Vin=10~15V, Io=500mA		
		08	—	3	80		Vin=11~17V, Io=500mA		
		09	—	4	90		Vin=13~19V, Io=500mA		
		10	—	4	100		Vin=14~20V, Io=500mA		
		12	—	5	120		Vin=16~22V, Io=500mA		
Ripple Rejection	R.R.	15	—	5	150	dB	Vin=20~26V, Io=500mA		
		18	—	5	180		Vin=24~30V, Io=500mA		
		20	—	7	200		Vin=26~32V, Io=500mA		
		24	—	10	240		Vin=30~33V, Io=500mA		
		05	62	78	—		dB	ein=1Vrms, f=120Hz, Io=100mA	
		06	59	73	—				
		07	57	69	—				
		08	56	65	—				
		09	56	64	—				
10	55	64	—						
12	55	63	—						
15	54	62	—						
18	53	61	—						
Temperature Coefficient of Output Voltage	Tcvo	20/24	—	-0.7	—	mV/°C	Io=5mA, Tj=0~125°C		
		06/07/08/09/10/12	—	-0.5	—				
		15/18	—	-0.6	—				
		05	—	-1.0	—				
Peak Output Current	Io-p	common	—	1.7	—	A	Tj=25°C		
Dropout Voltage	Vd	common	—	2.0	—	V	Io=1A		

●BA78□□CP/FP

ELECTRICAL CHARACTERISTICS

(Ta=25°C, Vin=10V(05), 11V(06), 13V(07), 14V(08), 15V(09), 16V(10), 19V(12), 23V(15), 27V(18), 29V(20), 33V(24),
Io=500mA unless otherwise specified)

Parameter	Symbol	Type	Limit			Unit	Condition
			Min	Typ	Max		
Load Regulation 1	Reg.L1	05	—	15	100	mV	Io=5mA~1A
		06	—	16	120		
		07	—	17	140		
		08	—	19	160		
		09	—	20	180		
		10	—	21	200		
		12	—	23	200		
		15	—	27	300		
		18	—	30	360		
		20	—	32	400		
		24	—	37	480		
Load Regulation 2	Reg.L2	05	—	5	50	mV	Io=250mA~750mA
		06	—	6	60		
		07	—	6	70		
		08	—	7	80		
		09	—	8	90		
		10	—	8	90		
		12	—	10	100		
		15	—	10	150		
		18	—	12	180		
		20	—	14	200		
		24	—	15	240		
Output Noise Voltage	Vn	05	—	40	—	μV	f=10Hz~100kHz
		06	—	60	—		
		07	—	70	—		
		08	—	80	—		
		09	—	90	—		
		10	—	100	—		
		12	—	110	—		
		15	—	125	—		
		18	—	140	—		
		20	—	150	—		
		24	—	180	—		
Bias Current	Ib	common	—	4.5	8.0	mA	Io=0mA
Bias Current Change 1	Ib1	common	—	—	0.5	mA	Io=5mA~1A
Bias Current Change 2	Ib2	05	—	—	0.8	mA	Vin:8~25V, Io=500mA
		06	—	—	0.8		Vin:8.5~25V, Io=500mA
		07	—	—	0.8		Vin:9.5~25V, Io=500mA
		08	—	—	0.8		Vin:10.5~25V, Io=500mA
		09	—	—	0.8		Vin:11.5~26V, Io=500mA
		10	—	—	0.8		Vin:12.5~27V, Io=500mA
		12	—	—	0.8		Vin:14.5~30V, Io=500mA
		15	—	—	0.8		Vin:17.5~30V, Io=500mA
		18	—	—	0.8		Vin:21~33V, Io=500mA
		20	—	—	0.8		Vin:23~33V, Io=500mA
		24	—	—	0.8	Vin:27~33V, Io=500mA	
Short-Circuit Output Current	Ios	05/06/07/08	—	0.6	—	A	Vin=25V
		09/10/12/15/18/20/24	—	0.3	—		Vin=30V
Output Resistance	Ro	05	—	9	—	mΩ	f=1kHz
		06	—	10	—		
		07	—	10	—		
		08	—	10	—		
		09	—	10	—		
		10	—	11	—		
		12	—	12	—		
		15	—	14	—		
		18	—	17	—		
		20	—	19	—		
		24	—	27	—		

● BA78M□□ Characteristics data (Ta=25°C, Vin=10V(05), 14V(08), 23V(15) unless otherwise specified)

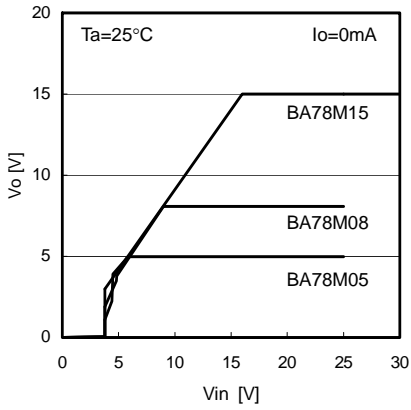

Fig.1 Line Regulation (Io=0mA)

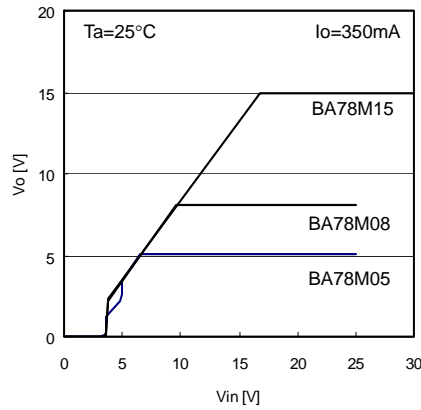

Fig.2 Line Regulation (Io=350mA)

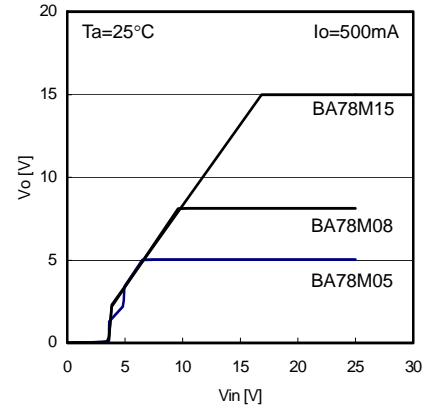

Fig.3 Line Regulation (Io=500mA)

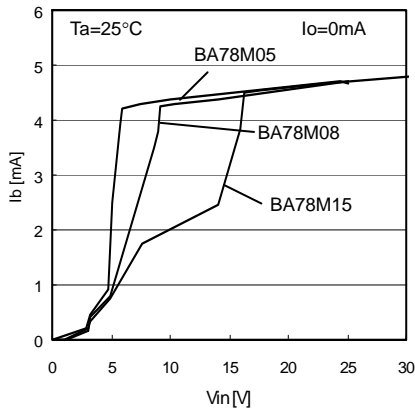

Fig.4 Vin - Ib

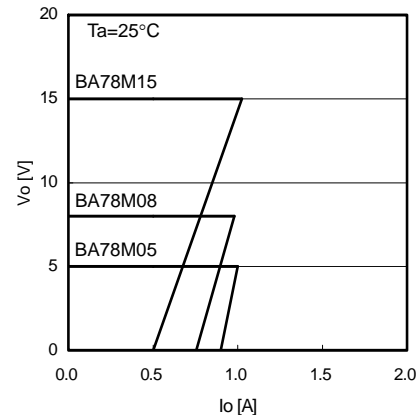

Fig.5 Load Regulation

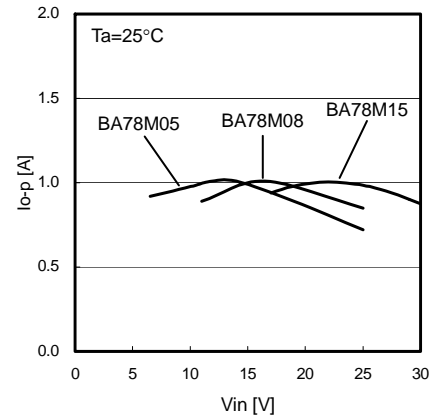

Fig.6 Peak Output Current

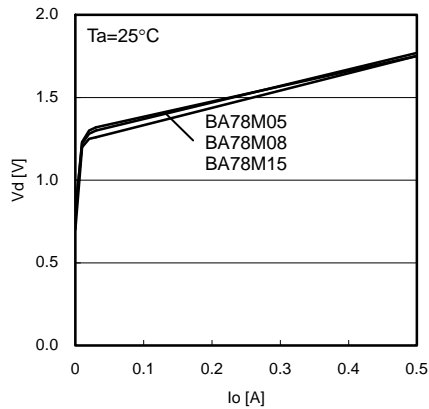

Fig.7 Dropout Voltage

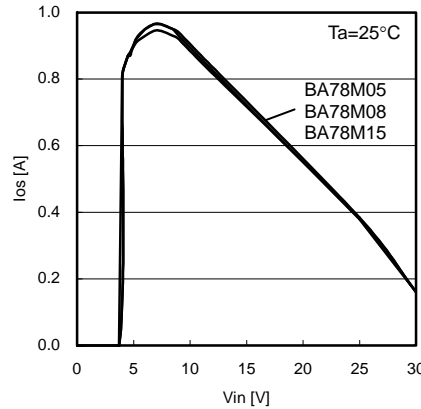

Fig.8 Short - Circuit Output Current

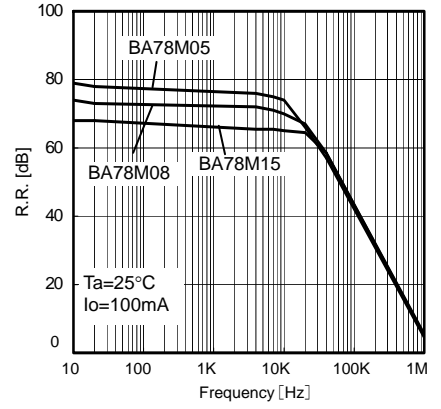

Fig.9 Ripple Rejection Ratio

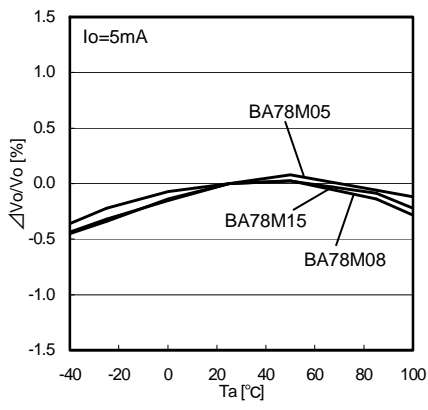

Fig.10 Ta - Vo

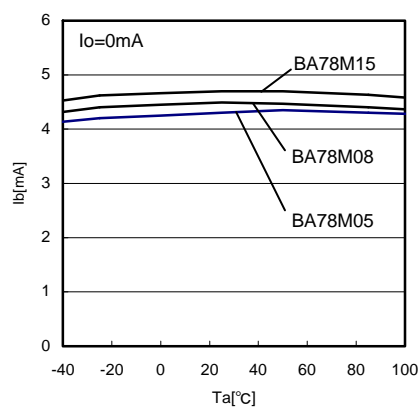

Fig.11 Ta - Ib

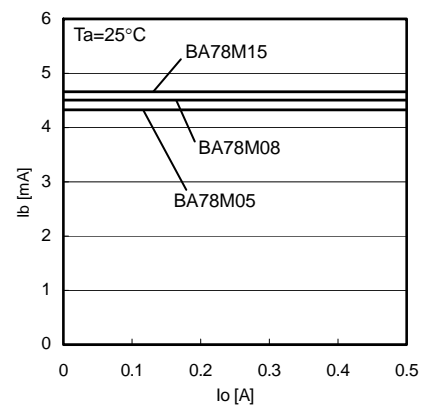

Fig.12 Io - Ib

● BA78□□ Characteristics data (Ta=25°C, Vin=10V(05), 14V(08), 23V(15) unless otherwise specified)

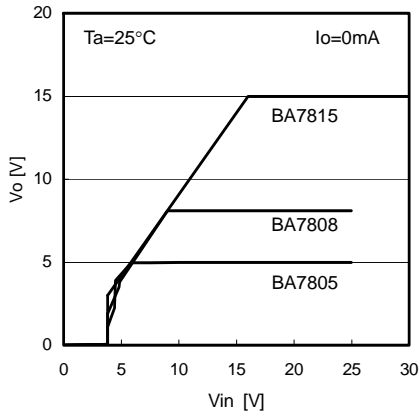

Fig.13 Line Regulation (Io=0mA)

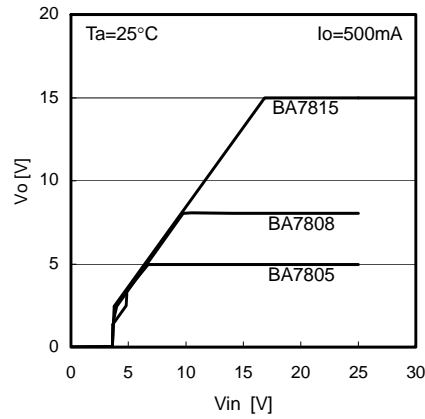

Fig.14 Line Regulation (Io=500mA)

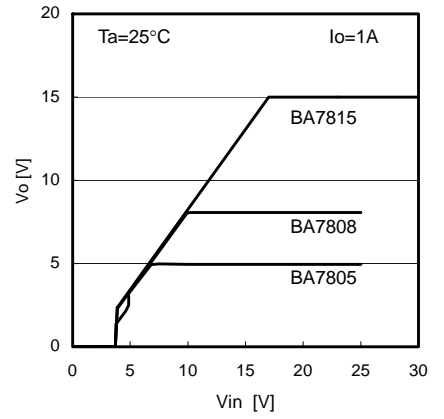

Fig.15. Line Regulation (Io=1A)

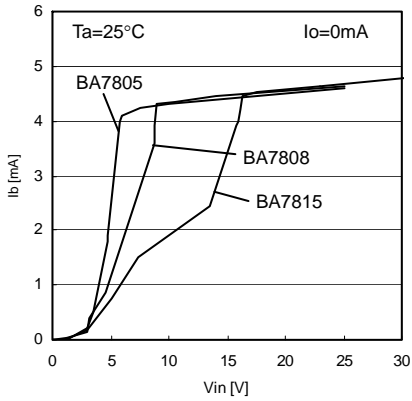

Fig.16 Vin - Ib

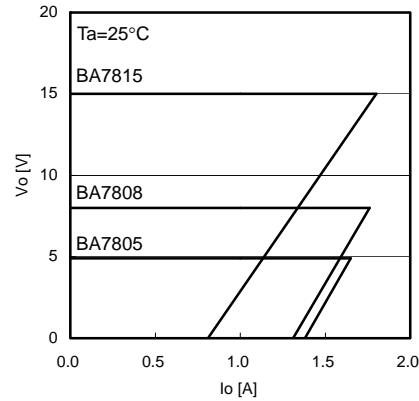

Fig.17 Load Regulation

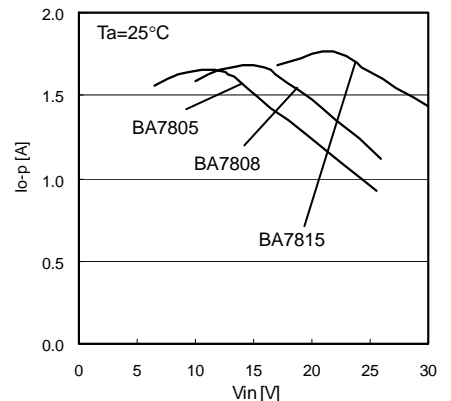

Fig.18 Peak Output Current

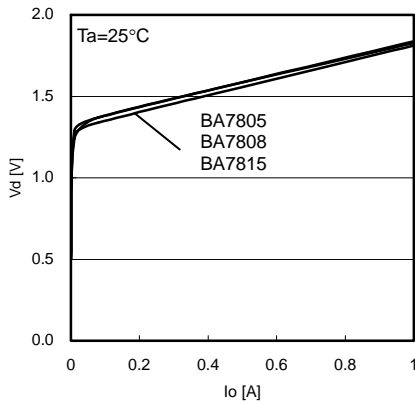

Fig.19 Dropout Voltage

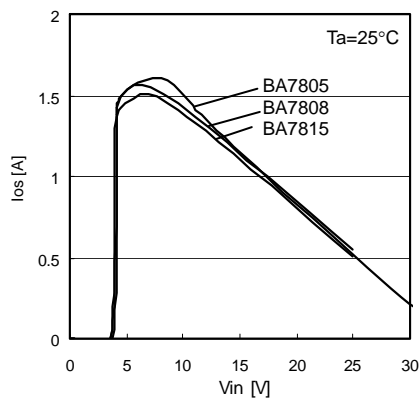

Fig.20 Short - Circuit Output Current

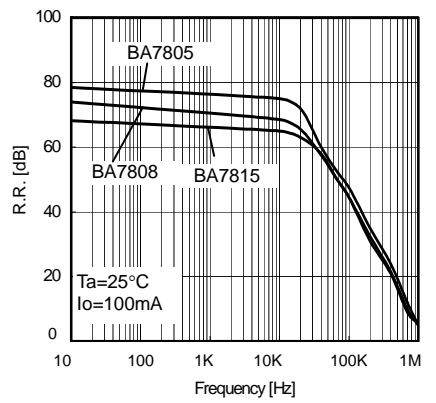

Fig.21 Ripple Rejection Ratio

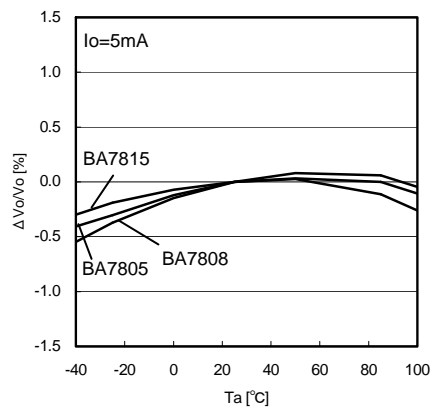

Fig.22 Ta - Vo

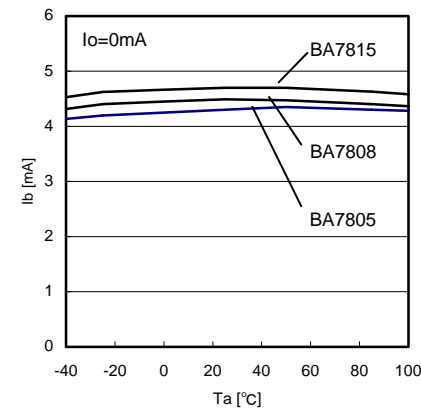

Fig.23 Ta - Ib

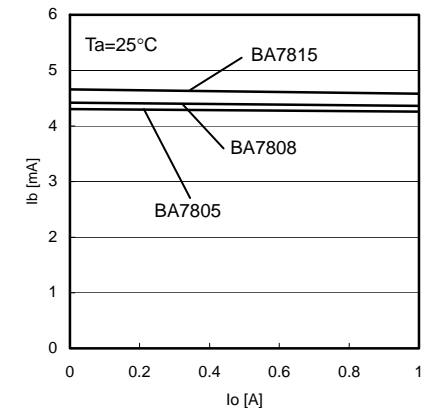
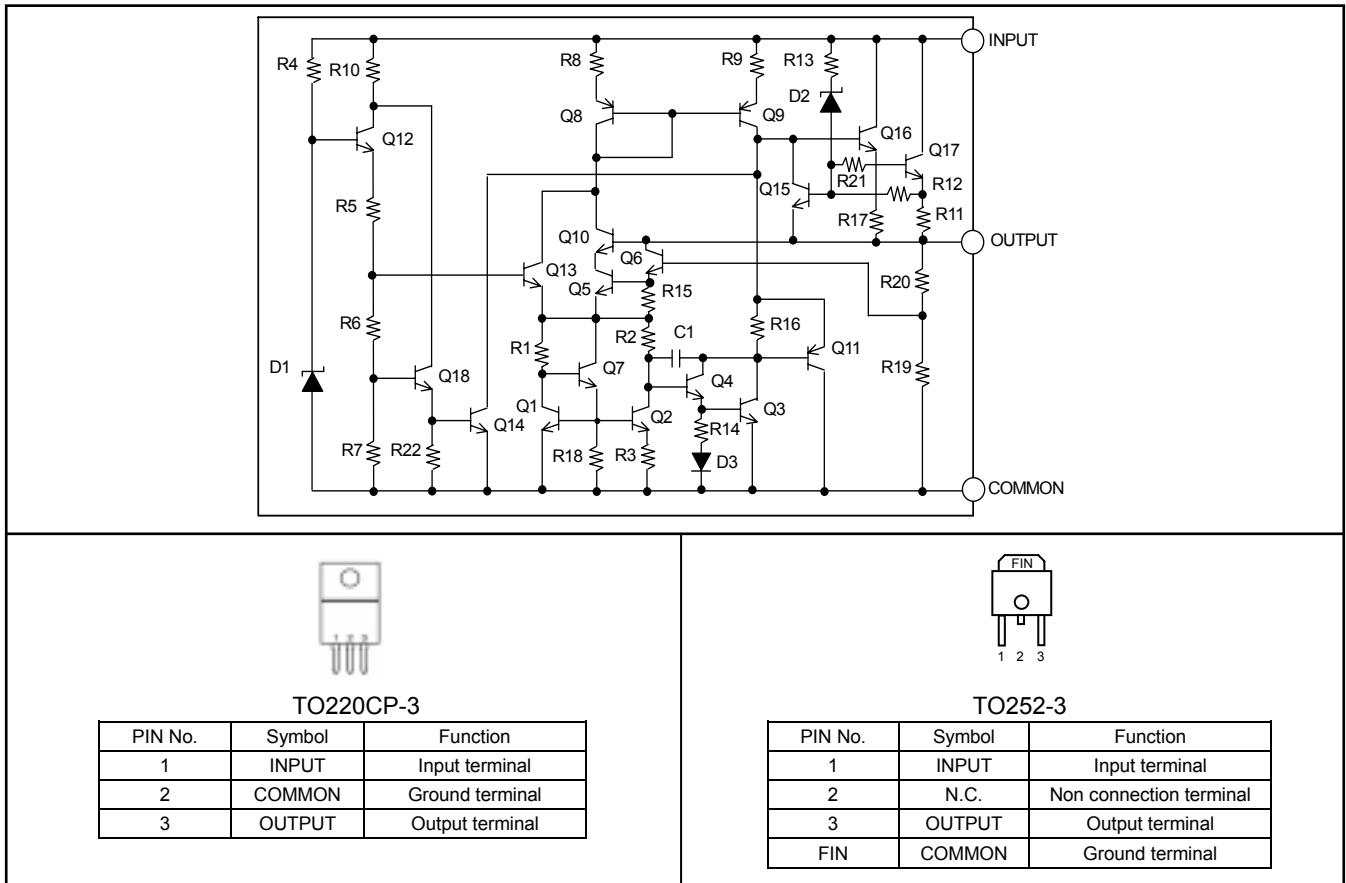

Fig.24 Io - Ib

● Internal Circuit Structural Diagram



● Protection Circuit

(1) Over-current protection circuit

When the maximum rating current or more is rushed, it controls the current ability and protects the IC from destruction.

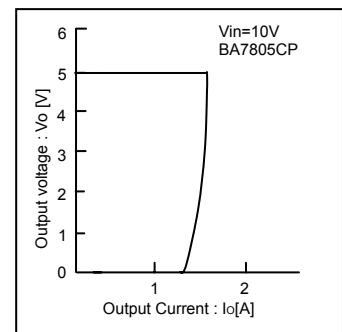

(2) Thermal shutdown circuit

When the chip temperature of IC exceeds the setting temperature, the IC goes OFF, and it controls the IC not to be destroyed by the heat generation. It can be restored by being lowered the chip temperature of IC below the setting temperature.

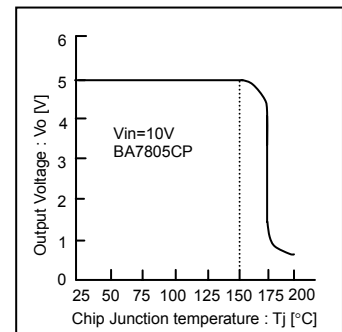

(3) Safety operation area control circuit

It controls the output current in inverse proportion ratio to voltage difference (input-output). When voltage difference becomes bigger, the IC will be destroyed in rush current. It protects the IC by controlling the current ability according to the voltage level.

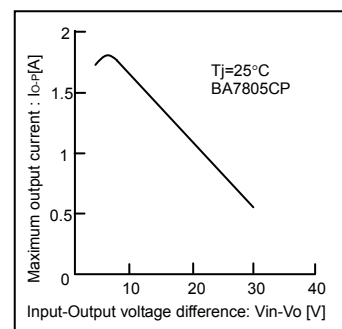

● Thermal design

Refer to the following thermal derating curves (Fig. 25, 26), when using in the status of Ta=25°C or more.

The characteristic of IC is greatly related to the operating temperature.

When it is used in over maximum junction temperature, the elements inside IC might become weaker and be destroyed.

It is recommended to take into consideration thermal of IC.

Note that the temperatures are in the allowed temperature limits and operated within Pd.

It is necessary to operate it at junction temperature Tjmax or less to prevent IC from the thermal destruction.

Please operate IC within permissible loss Pd because the junction temperature Tj might become considerably a high temperature even if ambient temperature Ta is normal temperature (25°C).

Power consumption Pc(W) may be expressed by the equation shown below:

$$P_c = (V_{in} - V_o) \times I_o + V_{in} \times I_b$$

permissible loss $P_d \geq P_c$

V_{in} : Input Voltage
 V_o : Output Voltage
 I_o : Output Current
 I_b : Bias current

$$I_o \leq \frac{P_d - V_{in} \times I_b}{V_{in} - V_o}$$

Maximum Output current I_{oMAX} can be calculated in thermal design.

• Calculation example

Ex.1) Ta=85°C, Vin =7.5V, Vo=5.0V

$$I_o \leq \frac{1.04 - 7.5 \times 4.5m}{7.5 - 5.0}$$

Using TO220CP-3 alone
 θja=62.5°C/W → 16mW/°C
 Pd=1.04W at 85°C

$$I_o \leq 400mA$$

Be sure to use this IC within a power dissipation at the range of operating temperature.

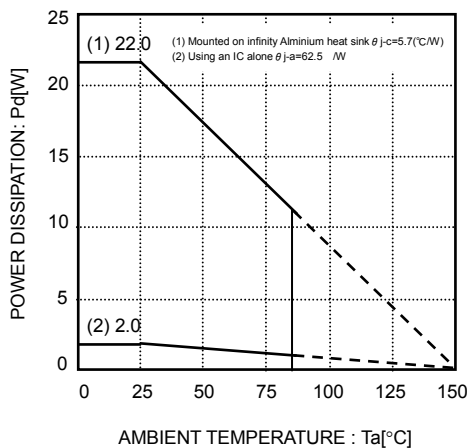

Fig.25 Thermal derating curve (TO220CP-3)

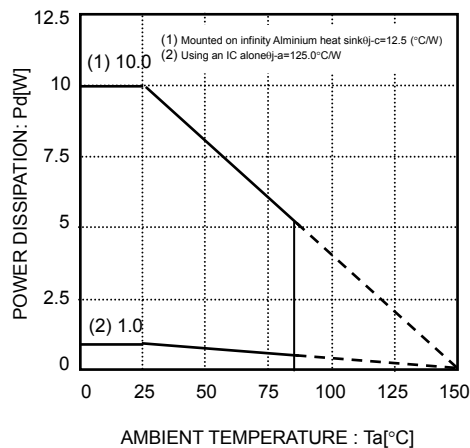

Fig.26 Thermal derating curve (TO252-3)

● Terminal Setting and Cautions

• INPUT

It is recommended that a capacitor (about 0.33uF) be inserted between INPUT and COMMON.
 The value of capacitor is designed suitable for the actual application.

• OUTPUT

It is recommended that a capacitor (about 0.1uF) be inserted between OUTPUT and COMMON.
 A tantalum capacitor can also be used for this pin because insufficient capacitors may cause oscillation by a temperature change.

• COMMON

Keep the no voltage drop between Ground level of set board and IC.
 When there is the voltage difference, setting voltage becomes inaccuracy and unstable.
 It is recommended to connect by wide, short pattern, and lower the impedance.

● Note For Use

(1) Absolute Maximum Ratings

While utmost care is taken to quality control of this product, any application that may exceed some of the absolute maximum ratings including the voltage applied and the operating temperature range may result in breakage. If broken, short-mode or open-mode may not be identified. So if it is expected to encounter with special mode that may exceed the absolute maximum ratings, it is requested to take necessary safety measures physically including insertion of fuses.

(2) Ground voltage

Make setting of the potential of the GND terminal so that it will be maintained at the minimum in any operating state. Furthermore, check to be sure no terminals are at a potential lower than the GND voltage including an actual electric transient.

(3) Thermal design

When you do the kind of use which exceeds Pd, It may be happened to deteriorating IC original quality such as decrease of electric current ability with chip temperature rise. Do not exceed the power dissipation (Pd) of the package specification rating under actual operation, and please design enough temperature margins.

(4) Short-circuiting between terminals, and mismounting

When mounting to pc board, care must be taken to avoid mistake in its orientation and alignment. Failure to do so may result in IC breakdown. Short-circuiting due to foreign matters entered between output terminals, or between output and power supply or GND may also cause breakdown.

(5) Operation in Strong electromagnetic field

Be noted that using the IC in the strong electromagnetic radiation can cause operation failures.

(6) Inspection with the IC set to a pc board

If a capacitor must be connected to the pin of lower impedance during inspection with the IC set to a pc board, the capacitor must be discharged after each process to avoid stress to the IC. For electrostatic protection, provide proper grounding to assembling processes with special care taken in handling and storage. When connecting to jigs in the inspection process, be sure to turn OFF the power supply before it is connected and removed.

(7) Input to IC terminals

This is a monolithic IC with P⁺ isolation between P-substrate and each element as illustrated below. This P-layer and the N-layer of each element form a P-N junction, and various parasitic element are formed.

If a resistor is joined to a transistor terminal as shown in Fig 28.

- P-N junction works as a parasitic diode if the following relationship is satisfied; GND > Terminal A (at resistor side), or GND > Terminal B (at transistor side); and
- if GND > Terminal B (at NPN transistor side),

a parasitic NPN transistor is activated by N-layer of other element adjacent to the above-mentioned parasitic diode.

The structure of the IC inevitably forms parasitic elements, the activation of which may cause interference among circuits, and/or malfunctions contributing to breakdown. It is therefore requested to take care not to use the device in such manner that the voltage lower than GND (at P-substrate) may be applied to the input terminal, which may result in activation of parasitic elements.

(8) Ground wiring pattern

If small-signal GND and large-current GND are provided, It will be recommended to separate the large-current GND pattern from the small-signal GND pattern and establish a single ground at the reference point of the set PCB so that resistance to the wiring pattern and voltage fluctuations due to a large current will cause no fluctuations in voltages of the small-signal GND. Pay attention not to cause fluctuations in the GND wiring pattern of external parts as well.

(9) Thermal shutdown circuit

A temperature control circuit is built in the IC to prevent the damage due to overheat.

Therefore, the output is turned off when the thermal circuit works and is turned on when the temperature goes down to the specified level.

But, built-in the IC a temperature control circuit to protect itself, and avoid the design used the thermal protection.

(10) Over current protection circuit

The over-current protection circuits are built in at output, according to their respective current outputs and prevent the IC from being damaged when the load is short-circuited or over-current. But, these protection circuits are effective for preventing destruction by unexpected accident. When it's in continuous protection circuit moving period don't use please. And for ability, because this chip has minus characteristic, be careful for heat plan.

(11) There is a possibility to damage an internal circuit or the element when Vin and the voltage of each terminal reverse in the application.

For instance, Vin is short-circuited to GND etc. with the charge charged to an external capacitor. Please use the capacitor of the output terminal with 1000μF or less. Moreover, the Vin series is recommended to insert the diode of the by-pass the diode of the backflow prevention or between each terminal and Vin.

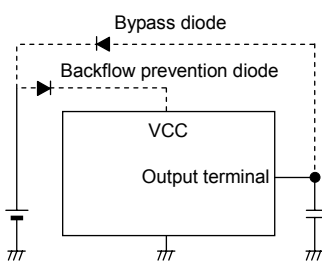

Fig.27 Bypass Diode

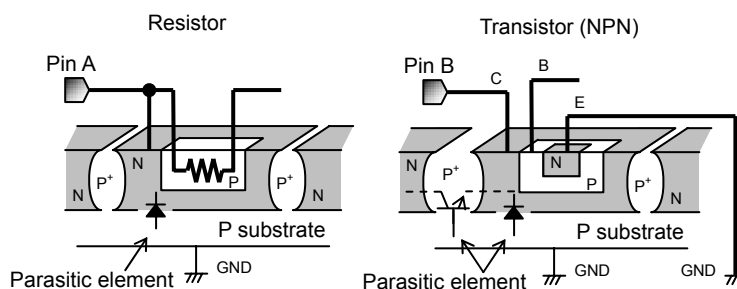
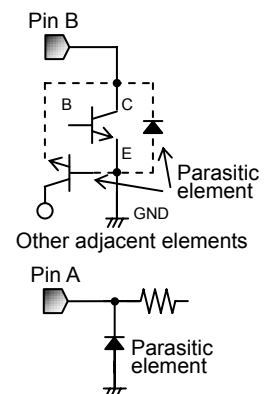
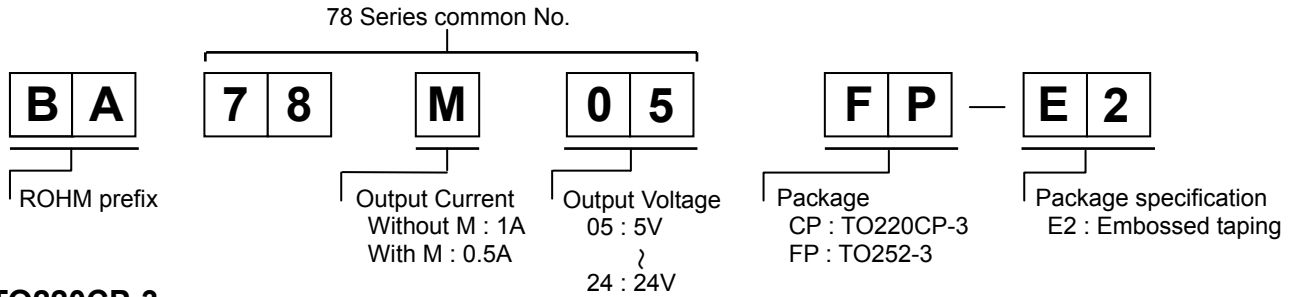

Fig.28 Simplified structure of monoristic IC



●Ordering part number



TO220CP-3

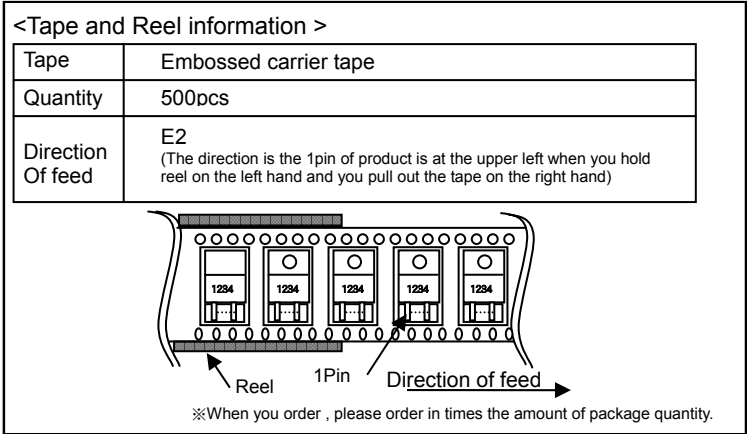
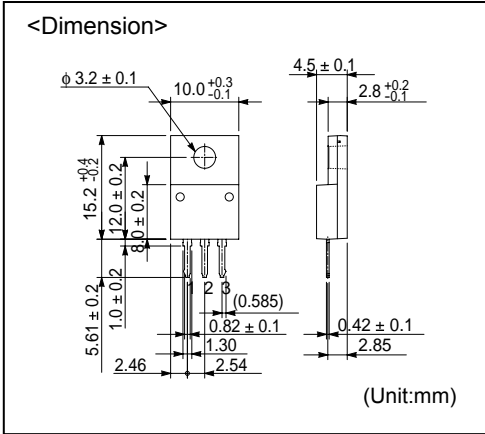

TO252-3

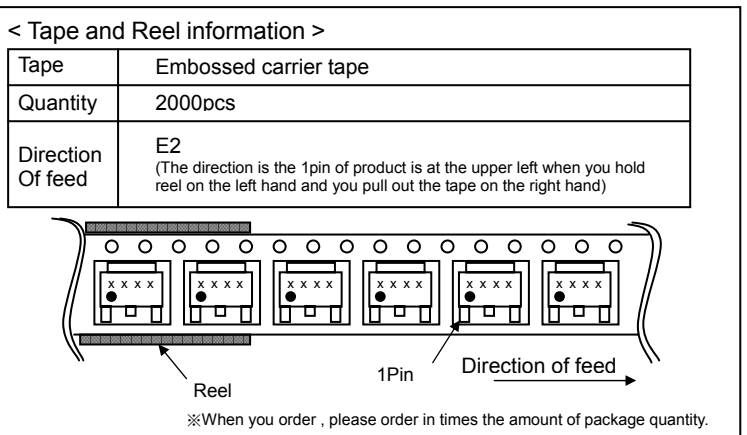
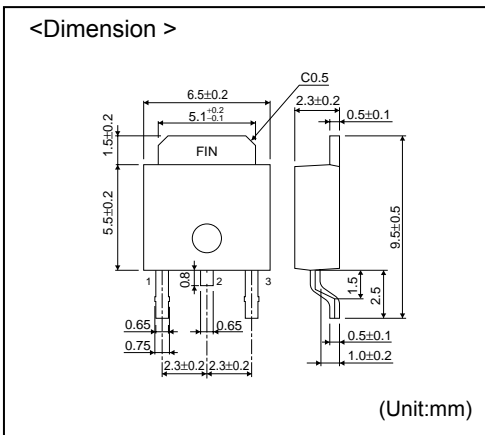

Notes

- No technical content pages of this document may be reproduced in any form or transmitted by any means without prior permission of ROHM CO.,LTD.
- The contents described herein are subject to change without notice. The specifications for the product described in this document are for reference only. Upon actual use, therefore, please request that specifications to be separately delivered.
- Application circuit diagrams and circuit constants contained herein are shown as examples of standard use and operation. Please pay careful attention to the peripheral conditions when designing circuits and deciding upon circuit constants in the set.
- Any data, including, but not limited to application circuit diagrams information, described herein are intended only as illustrations of such devices and not as the specifications for such devices. ROHM CO.,LTD. disclaims any warranty that any use of such devices shall be free from infringement of any third party's intellectual property rights or other proprietary rights, and further, assumes no liability of whatsoever nature in the event of any such infringement, or arising from or connected with or related to the use of such devices.
- Upon the sale of any such devices, other than for buyer's right to use such devices itself, resell or otherwise dispose of the same, no express or implied right or license to practice or commercially exploit any intellectual property rights or other proprietary rights owned or controlled by
- ROHM CO., LTD. is granted to any such buyer.
- Products listed in this document are no antiradiation design.

The products listed in this document are designed to be used with ordinary electronic equipment or devices (such as audio visual equipment, office-automation equipment, communications devices, electrical appliances and electronic toys).

Should you intend to use these products with equipment or devices which require an extremely high level of reliability and the malfunction of which would directly endanger human life (such as medical instruments, transportation equipment, aerospace machinery, nuclear-reactor controllers, fuel controllers and other safety devices), please be sure to consult with our sales representative in advance.

It is our top priority to supply products with the utmost quality and reliability. However, there is always a chance of failure due to unexpected factors. Therefore, please take into account the derating characteristics and allow for sufficient safety features, such as extra margin, anti-flammability, and fail-safe measures when designing in order to prevent possible accidents that may result in bodily harm or fire caused by component failure. ROHM cannot be held responsible for any damages arising from the use of the products under conditions out of the range of the specifications or due to non-compliance with the NOTES specified in this catalog.

Thank you for your accessing to ROHM product informations.

More detail product informations and catalogs are available, please contact your nearest sales office.

ROHM Customer Support System

THE AMERICAS / EUROPE / ASIA / JAPAN

www.rohm.com

Contact us : webmaster@rohm.co.jp