

TECHNICALS FEATURES

MATERIAL

INSULATOR : Special PPS (Polyphenylene Sulfide Fibreglass filled thermoplastic) UL 94-V0

- Radiation resistance
- No humidity absorption
- Oxygen free

Note : PPS characteristics are recognized for space applications

SIGNAL CONTACTS for PCB:

Male :

- **Contact area** : Copper alloy / Ni + Au 1µ
- **Contact tail** : Copper alloy / Ni + Au flash 0.1µ

FIXING HARDWARE :

- **Jackscrew** : Stainless steel

ELECTRICAL for LF Contacts

- **All contacts** : 3 A max. @ 25°C
2.2 A max. @ 85°C
Tested at 800 V DC
- **Working voltage (sea level)** : Tested at 1200 V DC
- **Proof voltage** : max. 10 mΩ
- **Contact resistance (initially)** : 1000 MΩ min
- **Insulation resistance** : 1000 MΩ min

MECHANICAL for LF Contacts

- **Mechanical operations** : 500 cycles min. up to 2500
- **Contact insertion and withdrawal force** : 2 N max. / 0.2 N min. per contact

ENVIRONMENTAL

- **Temperature range** : From -60°C to +260°C
- **Vibration severity** : 0.75mm, 10 g RMS 6 hours long random with superimposed sinusoid. No intermittencies measured when using an H.S.L.I. (High Speed Logic Interrupt) detector with a trip threshold of 2 ns.
- **Shock severity** : 100g for 6 ms
- **Solvent resistance** : HcFc 141 bMGX (ATOCHEM) solvent
- **Salt spray test** : 96 hrs
- **Humidity test** : 56 days @ 90% humidity



CONNECTOR SERIES 220 MALE

LF contacts number mm	Distance in mm between axes		Length in mm	LF contacts reference mark number			
	A	B		D	E	F	G
04	2	9	14	1	2	3	4
06	4	11	16	1	3	4	6
08	6	13	18	1	4	5	8
10	8	15	20	1	5	6	10
12	10	17	22	1	6	7	12
14	12	19	24	1	7	8	14
16	14	21	26	1	8	9	16
18	16	23	28	1	9	10	18
20	18	25	30	1	10	11	20
22	20	27	32	1	11	12	22
24	22	29	34	1	12	13	24
26	24	31	36	1	13	14	26
28	26	33	38	1	14	15	28
30	28	35	40	1	15	16	30
32	30	37	42	1	16	17	32
34	32	39	44	1	17	18	34
36	34	41	46	1	18	19	36
38	36	43	48	1	19	20	38
40	38	45	50	1	20	21	40
42	40	47	52	1	21	22	42
44	42	49	54	1	22	23	44
46	44	51	56	1	23	24	46
48	46	53	58	1	24	25	48
50	48	55	60	1	25	26	50
52	50	57	62	1	26	27	52
54	52	59	64	1	27	28	54
56	54	61	66	1	28	29	56
58	56	63	68	1	29	30	58
60	58	65	70	1	30	31	60

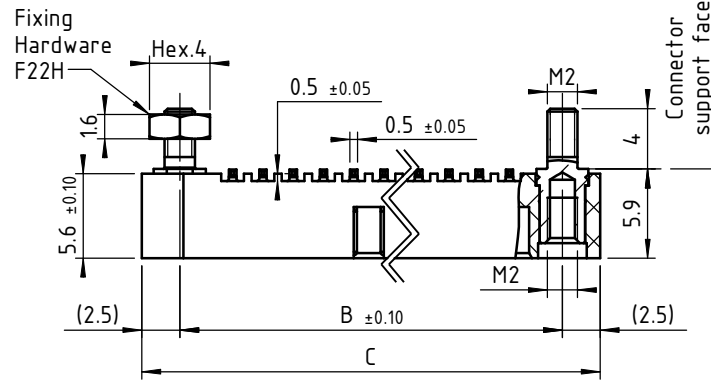

Recommended PCB layout :

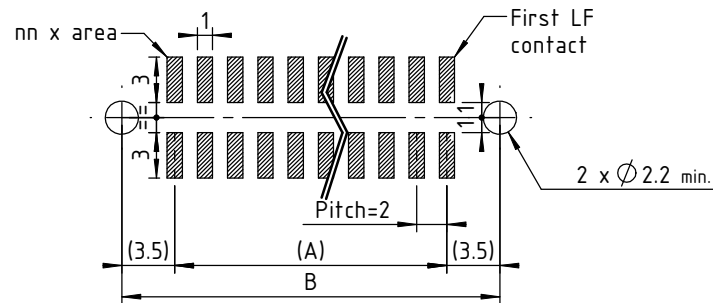

3D view scale: 1.5:1

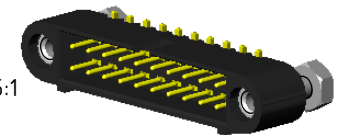

Marking as referenced in the CMM catalogue pages 12 & 13

 www.nicomatic.com Mail : nicomatic@nicomatic.fr Tel : +33 (0)4.50.36.13.85	2	07/12/10	N.P.	A.V.	E.M.
	Iss	Date	Drawn	Checked	Approved
Item : Connector CMM220 male straight SMT, nn LF contacts, F22H					
Folder : X:\Méthodes\Plans clients\Plans clients 2D\10 - CMM220\Connecteurs mâles\221T\221TnnF22H_cl					

This document and drawings, sketches, and schematic drawings are the property of the NICOMATIC company, and no parts thereof may be reproduced and used without the written consent of the owner. Law dated 11.03.1902

Catalogue Reference : 221TnnF22H



General tolerance	±0.2	Scale	2:1	Page	1/1
-------------------	------	-------	-----	------	-----