

DO NOT SCALE FROM THIS PRINT

PTF-1XX-XX-X-D-XXX

No OF POSITIONS
-02 THRU -50
(PER ROW)

POLARIZATION OPTION
-XXX INDICATES POSITION
(USE PK-07 TO POLARIZE)

LEAD STYLE
-01: USE C-159-01-XX
-03: USE C-159-03-XX

ROW SPECIFICATION
-D: DOUBLE ROW
-01 (USE PTF-62-D)
-03 (USE PTF-62-D & PTEF-50-D)

PLATING SPECIFICATION
-S: 30μ" SELECTIVE GOLD IN CONTACT AREA, MATTE TIN ON TAIL
-SM: 30μ" SELECTIVE GOLD IN CONTACT AREA, MATTE TIN ON TAIL
-L: 10μ" LIGHT SELECTIVE GOLD IN CONTACT AREA, MATTE TIN ON TAIL

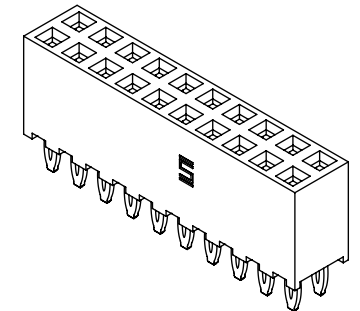
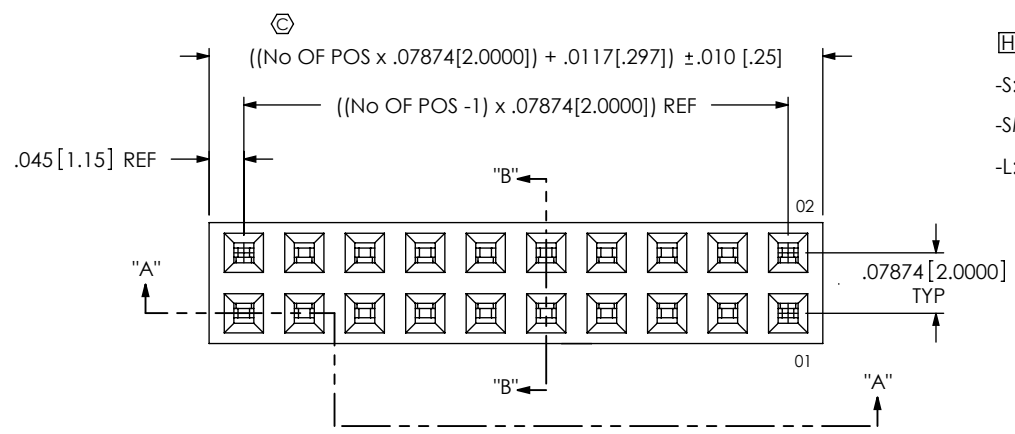
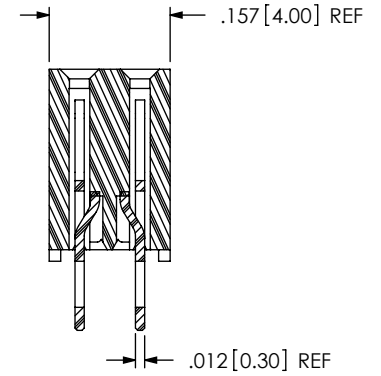
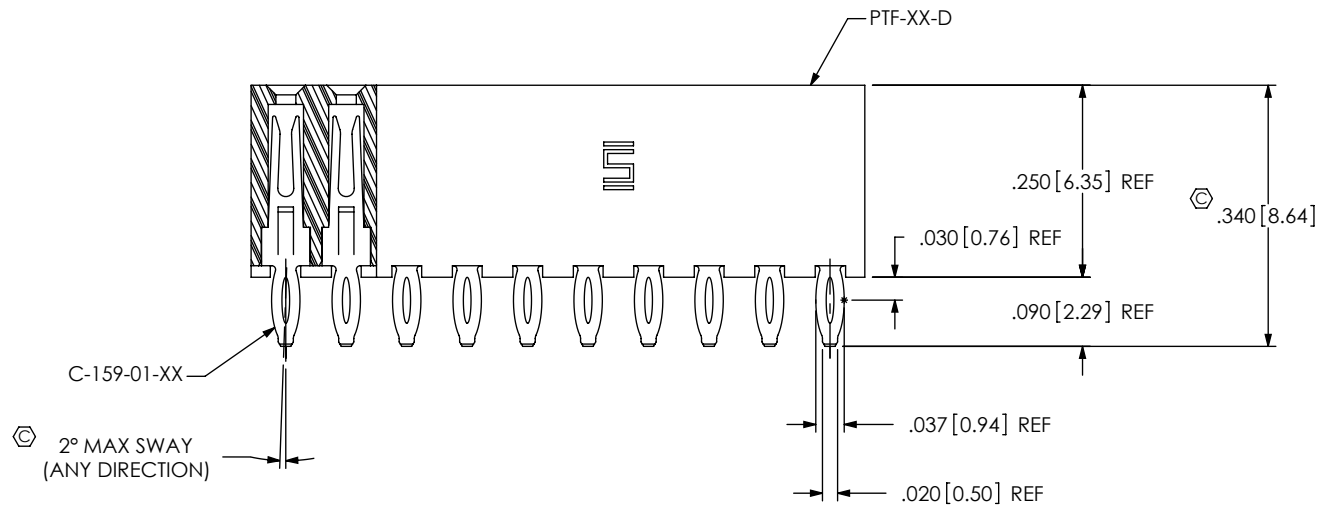

FIG 1
-01 LEAD STYLE



SECTION "A"- "A"

SECTION "B"- "B"

- NOTES:
1. Ⓢ REPRESENTS A CRITICAL DIMENSION.
 2. MAXIMUM CUT FLASH: .020 [.51].
 3. MINIMUM CONTACT RETENTION: .5 LB PER PIN.
 4. PARTS MAY BE CUT TO POS. ONE POS LOST PER CUT.
 5. ALL POSITIONS TO BE LAYER PACKAGED.
 6. MAX ALLOWABLE BOW .0015" IN/IN.
 7. NOTE DELETED.
 8. USED FOR CUTTING PTFE BODY
 9. PTFE BODY IS NOT TO BE MORE THAN +/- .005[.13] FROM PLANE SET BY PTFE BODY.

UNLESS OTHERWISE SPECIFIED, DIMENSIONS ARE IN INCHES. TOLERANCES ARE:
DECIMALS ANGLES
.XXX: ±.005 [.13] 2°
.XXX: ±.0020 [.051]
.XXXX: ±.0020 [.051]

PROPRIETARY NOTE
THIS DOCUMENT CONTAINS INFORMATION CONFIDENTIAL AND PROPRIETARY TO SAMTEC, INC. AND SHALL NOT BE REPRODUCED OR TRANSFERRED TO OTHER DOCUMENTS OR DISCLOSED TO OTHERS OR USED FOR ANY PURPOSE OTHER THAN THAT WHICH IT WAS OBTAINED WITHOUT THE EXPRESSED WRITTEN CONSENT OF SAMTEC, INC.

samtec
520 PARK EAST BLVD, NEW ALBANY, IN 47150
PHONE: 812-944-6733 FAX: 812-948-5047
e-Mail: info@SAMTEC.com code: 55322

MATERIAL: DO NOT SCALE DRAWING SHEET SCALE: 4:1
INSULATOR: LCP
COLOR: BLACK
CONTACT: PHOS BRONZE

DESCRIPTION: 2mm PRESS FIT SOCKET ASSEMBLY
DWG. NO. PTF-1XX-XX-X-D-XXX

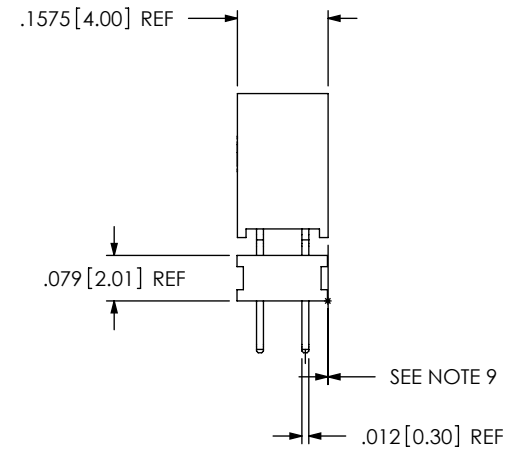
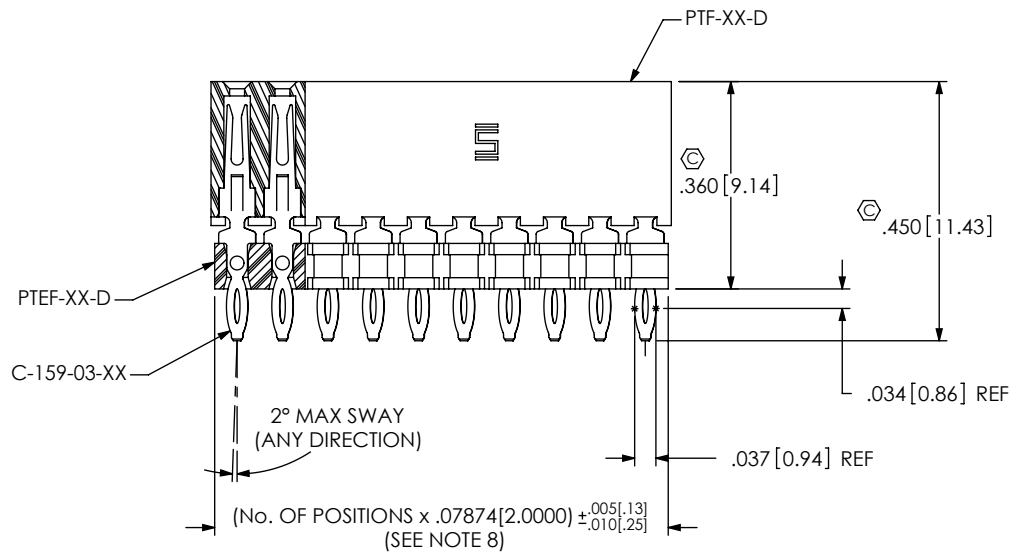
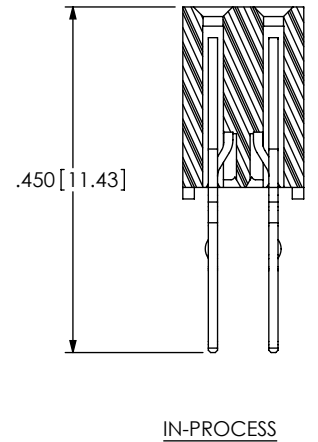
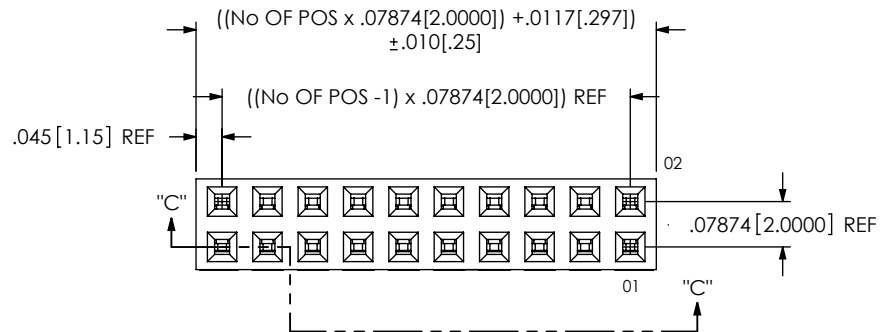

FIG. 2
-03 LEAD STYLE
SECTION "C"- "C"

PROPRIETARY NOTE
 THIS DOCUMENT CONTAINS INFORMATION CONFIDENTIAL AND PROPRIETARY TO SAMTEC, INC. AND SHALL NOT BE REPRODUCED OR TRANSFERRED TO OTHER DOCUMENTS OR DISCLOSED TO OTHERS OR USED FOR ANY PURPOSE OTHER THAN THAT WHICH IT WAS OBTAINED WITHOUT THE EXPRESSED WRITTEN CONSENT OF SAMTEC, INC.

DO NOT SCALE DRAWING

SHEET SCALE: 4:1

samtec
 520 PARK EAST BLVD, NEW ALBANY, IN 47150
 PHONE: 812-944-6733 FAX: 812-948-5047
 e-Mail: info@SAMTEC.com code: 55322

DESCRIPTION:
 2mm PRESS FIT SOCKET ASSEMBLY

DWG. NO.
 PTF-1XX-XX-X-D-XXX

BY: KEVIN B 4/3/2000 SHEET 2 OF 2