

RN2907~RN2909

SILICON PNP EPITAXIAL TYPE

SWITCHING, INVERTER CIRCUIT, INTERFACE CIRCUIT
AND DRIVER CIRCUIT APPLICATIONS.

- Including Two Devices in US6
(Ultra Super Mini Type with 6 leads)
- With Built-in Bias Resistors
- Simplify Circuit Design
- Reduce a Quantity of Parts and Manufacturing Process
- Complementary to RN1907~1909

EQUIVALENT CIRCUIT AND BIAS RESISTOR VALUES

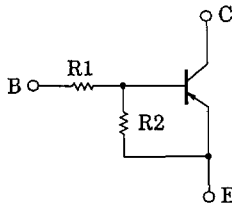

TYPE No.	R1 (kΩ)	R2 (kΩ)
RN2907	10	47
RN2908	22	47
RN2909	47	22

MAXIMUM RATINGS (Ta = 25°C) (Q1, Q2 COMMON)

CHARACTERISTIC		SYMBOL	RATING	UNIT
Collector-Base Voltage	RN2907~2909	V _{CB0}	-50	V
Collector-Emitter Voltage	RN2907~2909	V _{CEO}	-50	V
Emitter-Base Voltage	RN2907	V _{EB0}	-6	V
	RN2908		-7	
	RN2909		-15	
Collector Current	RN2907~2909	I _C	-100	mA
Collector Power Dissipation	RN2907~2909	P _C *	200	mW
Junction Temperature	RN2907~2909	T _j	150	°C
Storage Temperature Range	RN2907~2909	T _{stg}	-55~150	°C

* : Total Rating

Unit in mm

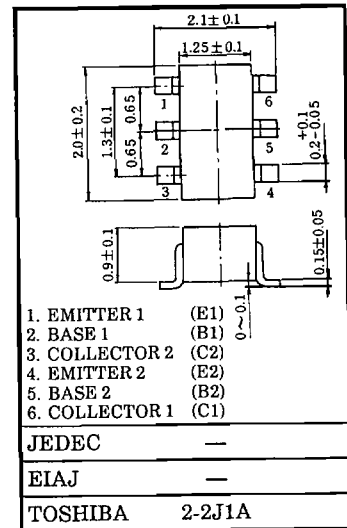

Weight : 6.8mg

EQUIVALENT CIRCUIT (TOP VIEW)

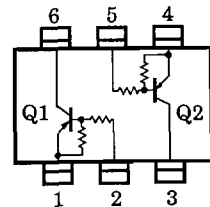

ELECTRICAL CHARACTERISTICS (Ta = 25°C) (Q1, Q2 COMMON)

CHARACTERISTIC		SYMBOL	TEST CONDITION	MIN.	TYP.	MAX.	UNIT
Collector Cut-off Current	RN2907~2909	ICBO	V _{CB} = -50V, I _E = 0	—	—	-100	nA
		ICEO	V _{CE} = -50V, I _B = 0	—	—	-500	nA
Emitter Cut-off Current	RN2907	IEBO	V _{EB} = -6V, I _C = 0	-0.081	—	-0.15	mA
	RN2908		V _{EB} = -7V, I _C = 0	-0.078	—	-0.145	
	RN2909		V _{EB} = -15V, I _C = 0	-0.167	—	-0.311	
DC Current Gain	RN2907	h _{FE}	V _{CE} = -5V, I _C = -1mA	80	—	—	
	RN2908			80	—	—	
	RN2909			70	—	—	
Collector-Emitter Saturation Voltage	RN2907~2909	V _{CE(sat)}	I _C = -5mA, I _B = -0.25mA	—	-0.1	-0.3	V
Input Voltage (ON)	RN2907	V _{I(ON)}	V _{CE} = -0.2V, I _C = -5mA	-0.7	—	-1.8	V
	RN2908			-1.0	—	-2.6	
	RN2909			-2.2	—	-5.8	
Input Voltage (OFF)	RN2907	V _{I(OFF)}	V _{CE} = -5V, I _C = -0.1mA	-0.5	—	-1.0	V
	RN2908			-0.6	—	-1.16	
	RN2909			-1.5	—	-2.6	
Transition Frequency	RN2907~2909	f _T	V _{CE} = -10V, I _C = -5mA	—	200	—	MHz
Collector Output Capacitance	RN2907~2909	C _{ob}	V _{CB} = -10V, I _E = 0, f = 1MHz	—	3	6	pF
Input Resistor	RN2907	R1		7	10	13	kΩ
	RN2908			15.4	22	28.6	
	RN2909			32.9	47	61.1	
Resistor Ratio	RN2907	R1 / R2		0.191	0.213	0.232	
	RN2908			0.421	0.468	0.515	
	RN2909			1.92	2.14	2.35	

RN2907~RN2909

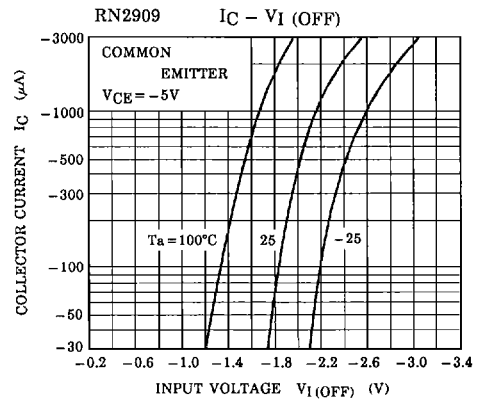
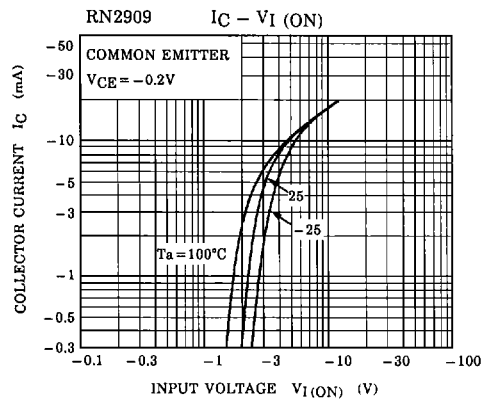
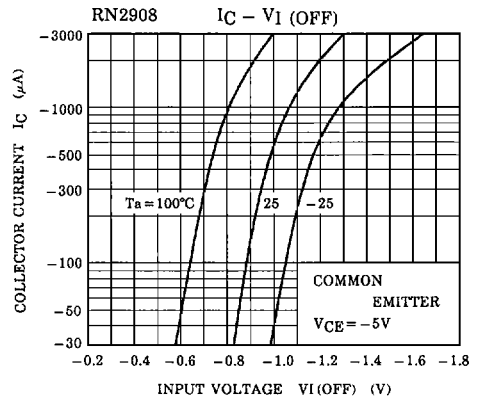
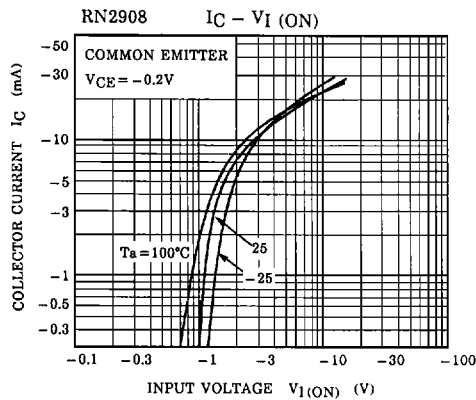
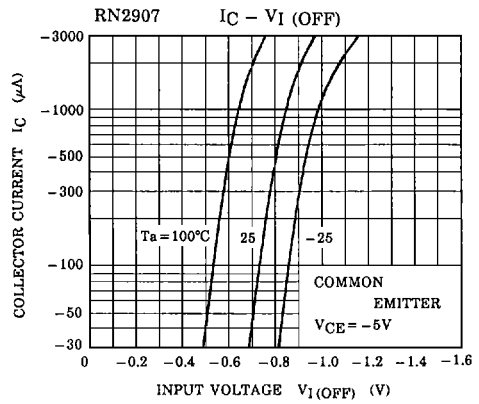
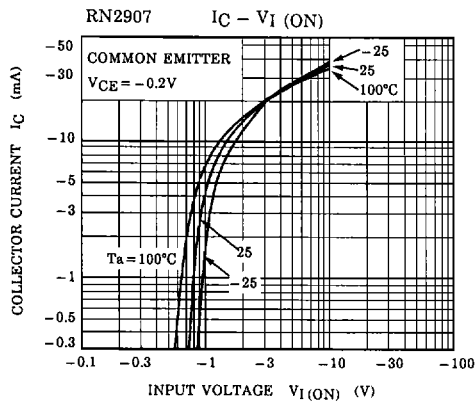

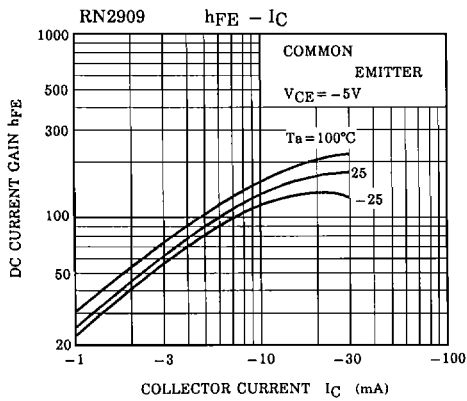
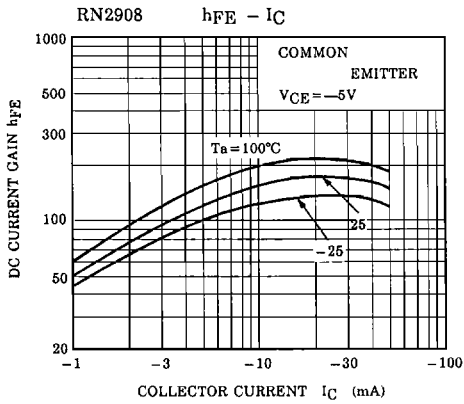
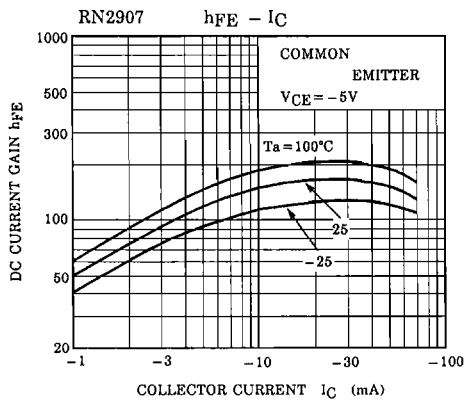

RN2907~RN2909

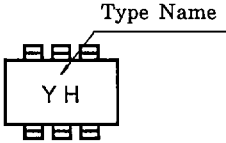
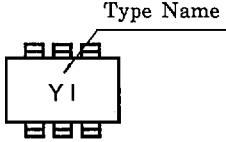
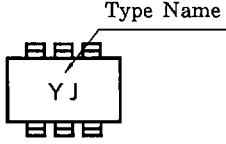
TYPE NAME	MARKING
RN2907	 A diagram of a rectangular component with four pins on each of the top and bottom edges. The letters 'YH' are printed in the center. A line points from the text 'Type Name' to the top edge of the component.
RN2908	 A diagram of a rectangular component with four pins on each of the top and bottom edges. The letters 'YI' are printed in the center. A line points from the text 'Type Name' to the top edge of the component.
RN2909	 A diagram of a rectangular component with four pins on each of the top and bottom edges. The letters 'YJ' are printed in the center. A line points from the text 'Type Name' to the top edge of the component.