



MOTOROLA

Dual J-K Flip-Flop With Clear and Preset

**ELECTRICALLY TESTED PER:
MIL-M-38510/30109**

The 54LS109A consists of two high-speed completely independent transition clocked J-K flip-flops. The clocking operation is independent of the rise and fall times of the clock waveform. The J-K design allows operation as a D flip-flop by simply connecting the J and \bar{K} pins together.

LOGIC DIAGRAM (one half shown)

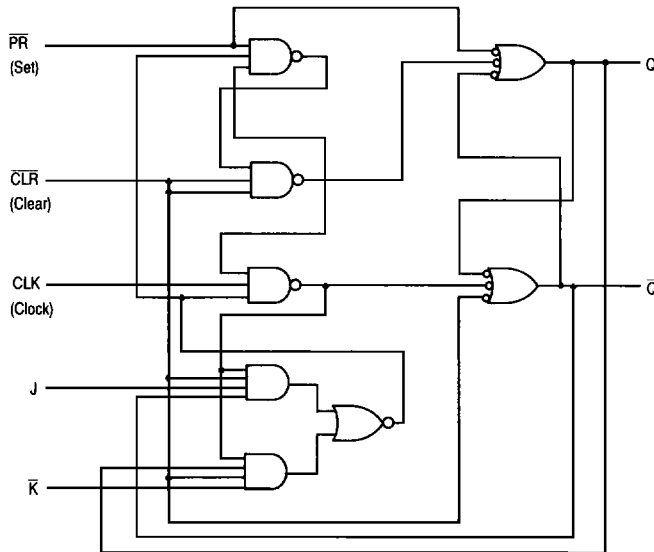

Please note that this diagram is provided only for the understanding of logic operations and should not be used to estimate propagation delays.

*Both outputs will be HIGH while both \overline{PR} and \overline{CLR} are LOW, but the output states are unpredictable if \overline{PR} and \overline{CLR} go HIGH simultaneously.

Military 54LS109A



AVAILABLE AS:

- 1) JAN: JM38510/30109BXA
- 2) SMD: N/A
- 3) 883: 54LS109A/BXAJC

**X = CASE OUTLINE AS FOLLOWS:
PACKAGE: CERDIP: E
CERFLAT: F
LCC: 2**

**THE LETTER "M" APPEARS
BEFORE THE / ON LCC.**

PIN ASSIGNMENTS

FUNCT.	DIL 620-09	FLATS 850-05	LCC 756A-02	BURN-IN (COND. A)
\overline{CLR}_1	1	1	2	GND
J ₁	2	2	3	VCC
\bar{K}_1	3	3	4	VCC
CLK ₁	4	4	5	GND
\overline{PR}_1	5	5	7	GND
Q ₁	6	6	8	VCC
\bar{Q}_1	7	7	9	VCC
GND	8	8	10	GND
\bar{Q}_2	9	9	12	VCC
Q ₂	10	10	13	VCC
\overline{PR}_2	11	11	14	GND
CLK ₂	12	12	15	GND
\bar{K}_2	13	13	17	VCC
J ₂	14	14	18	VCC
\overline{CLR}_2	15	15	19	GND
VCC	16	16	20	VCC

BURN-IN CONDITIONS:

VCC = 5.0 V MIN/6.0 V MAX

54LS109A

AC TEST CIRCUIT

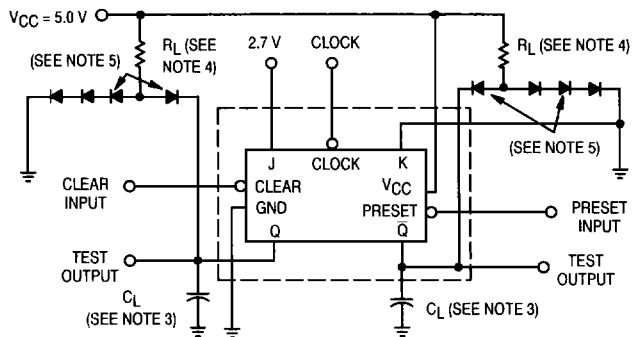

WAVEFORMS

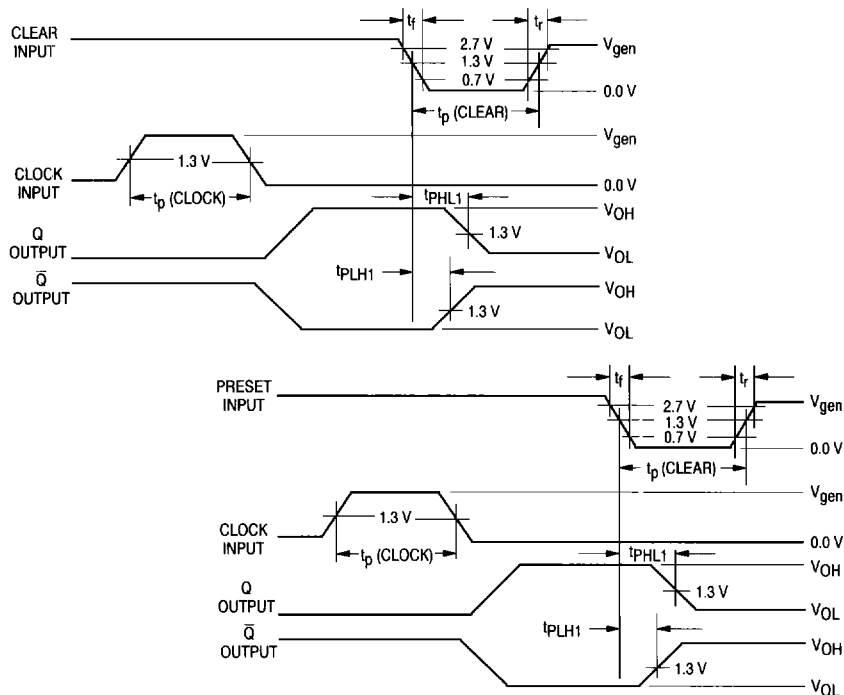

NOTES:

1. Clear or preset inputs dominate regardless of the state of clock J-K inputs.
2. Clear or preset input pulse characteristics: $V_{gen} = 3.0\text{ V}$, $t_r \leq 15\text{ ns}$, $t_f \leq 6.0\text{ ns}$, $PRR \leq 1.0\text{ MHz}$, $t_p(\text{clear}) = t_p(\text{preset}) = 30\text{ ns}$, $Z_{OUT} = 50\ \Omega$.
3. $C_L = 50\text{ pF} \pm 1.0\%$ (including jig and probe capacitance).
4. $R_L = 2.0\text{ k}\Omega \pm 5.0\%$.
5. All diodes are 1N3064, or equivalent.
6. When testing clear to output switching, preset shall have a logical "1" voltage applied. When testing preset to output switching, clear input shall have a logical "1" voltage applied (see table).
7. Clock input pulse characteristics: $t_p(\text{clock}) \geq 25\text{ ns}$, $V_{gen} = 3.0\text{ V}$, $PRR \leq 1.0\text{ MHz}$.

54LS109A

MODE SELECT — TRUTH TABLE						
Operating Mode	Inputs				Outputs	
	PR	CLR	J	\bar{K}	Q	\bar{Q}
Set	L	H	X	X	H	L
Reset (Clear)	H	L	X	X	L	H
*Undetermined	L	L	X	X	H	H
Toggle	H	H	h	i	\bar{q}	q
Load "0" (Reset)	H	H	l	l	L	H
Load "1" (Set)	H	H	h	h	H	L
Hold	H	H	l	h	q	\bar{q}

H, h = HIGH Voltage Level
 L, l = LOW Voltage Level
 X = Don't Care
 l, h (q) = Lower case letters indicate the state of referenced input (or output) one set-up time prior to the HIGH to LOW clock transition.

CONNECTION DIAGRAM

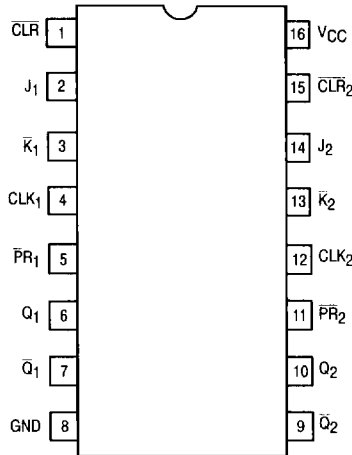

LOGIC SYMBOL

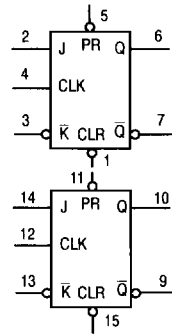

SYNCHRONOUS SWITCHING TEST CIRCUIT

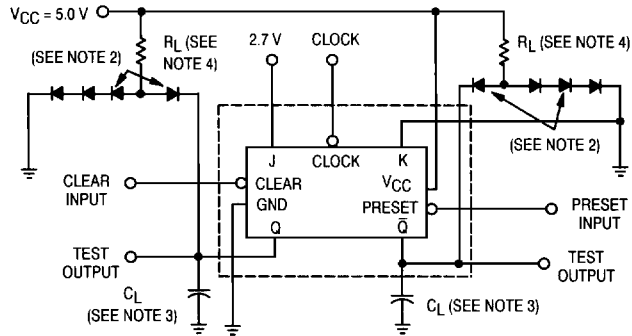

WAVEFORMS

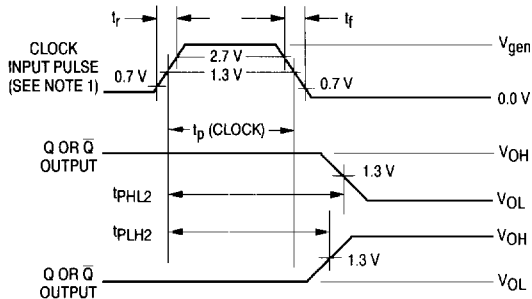

NOTES:

1. Clock input characteristics for t_{PLH} , t_{PHL} (clock to output): $V_{gen} = 3.0\text{ V}$, $t_r \leq 15\text{ ns}$, $t_f = 6.0\text{ ns}$, $t_p(\text{clock}) = 25\text{ ns}$ and $PRR \leq 1.0\text{ MHz}$. When testing f_{MAX} the clock input characteristics are: $V_{gen} = 3.0\text{ V}$, $t_r = t_f \leq 6.0\text{ ns}$, $t_p(\text{clock}) \leq 25\text{ ns}$ and $PRR =$ (see table on next page).
2. All diodes are 1N3064, or equivalent.
3. $C_L = 50\text{ pF} \pm 10\%$ (including jig and probe capacitance).
4. $R_L = 2.0\text{ k}\Omega \pm 5.0\%$.

54LS109A

Symbol	Parameter	Limits						Unit	Test Condition (Unless Otherwise Specified)
		+ 25°C		+ 125°C		- 55°C			
		Subgroup 1		Subgroup 2		Subgroup 3			
Static Parameters:		Min	Max	Min	Max	Min	Max		
V _{OH}	Logical "1" Output Voltage	2.5		2.5		2.5		V	V _{CC} = 4.5 V, I _{OH} = -0.4 mA, V _{IN} = 2.0 V, V _{IL} = 0.7 V.
V _{OL}	Logical "0" Output Voltage		0.4		0.4		0.4	V	V _{CC} = 4.5 V, I _{OL} = 4.0 mA, V _{IH} = 2.0 V, V _{IL} = 0.7 V.
V _{IC}	Input Clamping Voltage		-1.5					V	V _{CC} = 4.5 V, I _{IN} = -18 mA, other inputs are open.
I _{IH}	Logical "1" Input Current (J & K inputs)		20		20		20	μA	V _{CC} = 5.5 V, V _{IH} = 2.7 V, other inputs = 4.5 V, CLR = GND.
I _{IHH}	Logical "1" Input Current (J & K inputs)		100		100		100	μA	V _{CC} = 5.5 V, V _{IHH} = 5.5 V, CLK = 4.5 V, other inputs = 0 V.
I _{IH}	Logical "1" Input Current (CLK & PR)		40		40		40	μA	V _{CC} = 5.5 V, V _{IH} = 2.7 V, other inputs = 4.5 V, CLR & PR = GND.
I _{IHH}	Logical "1" Input Current (CLK & PR)		200		200		200	μA	V _{CC} = 5.5 V, V _{IHH} = 5.5 V, other inputs = 4.5 V, CLR = GND.
I _{IH}	Logical "1" Input Current (CLR inputs)		80		80		80	μA	V _{CC} = 5.5 V, V _{IH} = 2.7 V, CLK = GND, other inputs = 4.5 V.
I _{IHH}	Logical "1" Input Current (CLR inputs)		400		400		400	μA	V _{CC} = 5.5 V, V _{IHH} = 5.5 V, CLK = GND, other inputs = 4.5 V.
I _{IL}	Logical "0" Input Current (J & K inputs)	-0.135	-0.37	-0.135	-0.37	-0.135	-0.37	mA	V _{CC} = 5.5 V, V _{IL} = 0.4 V, PR & K = 4.5 V, CLK = (See Note 2).
I _{IL}	CLK	-0.12	-0.36	-0.12	-0.36	-0.12	-0.36	mA	V _{CC} = 5.5 V, V _{IL} = 0.4 V, J & K = 4.5 V, CLK & CLR = 4.5 V.
	PR	-0.28	-0.76	-0.28	-0.76	-0.28	-0.76		
I _{IL}	Logical "0" Input Current (CLR inputs)	-0.28	-0.76	-0.28	-0.76	-0.28	-0.76	mA	V _{CC} = 5.5 V, V _{IL} = 0.4 V, CLK - J & K = 4.5 V, PR = 0 V.
I _{OS}	Output Short Circuit Current	-15	-100	-15	-100	-15	-100	mA	V _{CC} = 5.5 V, V _{IN} = 4.5 V, CLK - CLR & J = GND, V _{OUT} = 0 V, other inputs are open.
I _{CC}	Power Supply Current		8.0		8.0		8.0	mA	V _{CC} = 5.5 V, V _{IN} = 0 V or V _{IN} = 5.5 V, other inputs are open.
V _{IH}	Logical "1" Input Voltage	2.0		2.0		2.0		V	V _{CC} = 4.5 V.
V _{IL}	Logical "0" Input Voltage		0.7		0.7		0.7	V	V _{CC} = 4.5 V.
	Functional Tests	Subgroup 7		Subgroup 8A		Subgroup 8B			per Truth Table with V _{CC} = 4.5 V, V _{INL} = 0.4 V, and V _{INH} = 2.5 V.

NOTES:

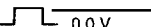
1. =  2.5 V min/5.5 V max

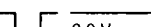
2. =  2.5 V min/5.5 V max

54LS109A

Symbol	Parameter	Limits						Unit	Test Condition (Unless Otherwise Specified)
		+ 25°C		+ 125°C		- 55°C			
		Subgroup 9		Subgroup 10		Subgroup 11			
		Min	Max	Min	Max	Min	Max		
t _{PHL1} t _{PHL1}	Propagation Delay /Data-Output Output High-Low	5.0 —	32 40	5.0 —	59 54	5.0 —	59 54	ns	V _{CC} = 5.0 V, C _L = 50 pF, R _L = 2.0 kΩ ± 5.0%. V _{CC} = 5.0 V, C _L = 15 pF, R _L = 2.0 kΩ ± 5.0%.
t _{PLH1} t _{PLH1}	Propagation Delay /Data-Output Output Low-High	5.0 —	20 25	5.0 —	39 34	5.0 —	39 34	ns	V _{CC} = 5.0 V, C _L = 50 pF, R _L = 2.0 kΩ ± 5.0%. V _{CC} = 5.0 V, C _L = 15 pF, R _L = 2.0 kΩ ± 5.0%.
t _{PHL2}	Propagation Delay /Data-Output Output High-Low	5.0	35	5.0	59	5.0	59	ns	V _{CC} = 5.0 V, C _L = 50 pF, R _L = 2.0 kΩ ± 5.0%.
t _{PLH2}	Propagation Delay /Data-Output Output Low-High	5.0	24	5.0	39	5.0	39	ns	V _{CC} = 5.0 V, C _L = 50 pF, R _L = 2.0 kΩ ± 5.0%.
f _{MAX}	Maximum Clock Frequency	20		20		20		MHz	V _{CC} = 5.0 V, V _{IN} = 2.7 V, C _L = 50 pF, R _L = 2.0 kΩ ± 5.0%.
f _{MAX}	Maximum Clock Frequency	25						MHz	V _{CC} = 5.0 V, C _L = 15 pF, R _L = 2.0 kΩ ± 5.0%.

NOTES:

1. f_{MAX}, min. limit specified is the frequency of the input pulse. The output frequency shall be one-half of the input frequency.
2. Tests shall be performed in sequence, attributes data only.
3. The limits specified for C_L = 15 pF are guaranteed but not tested.