

National Semiconductor is now part of
Texas Instruments.

Search <http://www.ti.com/> for the latest technical
information and details on our current products and services.

LM124/LM224/LM324/LM2902 Low Power Quad Operational Amplifiers

General Description

The LM124 series consists of four independent, high gain, internally frequency compensated operational amplifiers which were designed specifically to operate from a single power supply over a wide range of voltages. Operation from split power supplies is also possible and the low power supply current drain is independent of the magnitude of the power supply voltage.

Application areas include transducer amplifiers, DC gain blocks and all the conventional op amp circuits which now can be more easily implemented in single power supply systems. For example, the LM124 series can be directly operated off of the standard +5V power supply voltage which is used in digital systems and will easily provide the required interface electronics without requiring the additional $\pm 15V$ power supplies.

Unique Characteristics

- In the linear mode the input common-mode voltage range includes ground and the output voltage can also swing to ground, even though operated from only a single power supply voltage
- The unity gain cross frequency is temperature compensated
- The input bias current is also temperature compensated

Advantages

- Eliminates need for dual supplies
- Four internally compensated op amps in a single package
- Allows directly sensing near GND and V_{OUT} also goes to GND
- Compatible with all forms of logic
- Power drain suitable for battery operation

Features

- Internally frequency compensated for unity gain
- Large DC voltage gain 100 dB
- Wide bandwidth (unity gain) 1 MHz (temperature compensated)
- Wide power supply range:
Single supply 3V to 32V
or dual supplies $\pm 1.5V$ to $\pm 16V$
- Very low supply current drain (700 μA) — essentially independent of supply voltage
- Low input biasing current 45 nA (temperature compensated)
- Low input offset voltage 2 mV and offset current: 5 nA
- Input common-mode voltage range includes ground
- Differential input voltage range equal to the power supply voltage
- Large output voltage swing 0V to $V^+ - 1.5V$

Connection Diagram

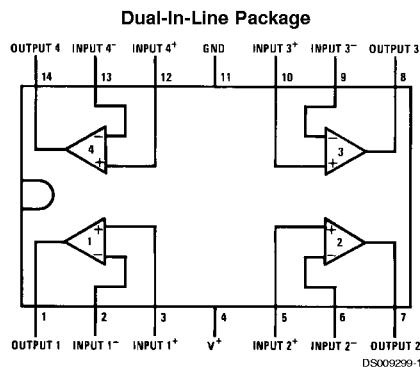

Order Number LM124J, LM124AJ, LM124J/883 (Note 2), LM124AJ/883 (Note 1), LM224J, LM224AJ, LM324J, LM324M, LM324AM, LM2902M, LM324N, LM324AN or LM2902N
LM124AJRQML and LM124AJRQMLV (Note 3)
See NS Package Number J14A, M14A or N14A

Note 1: LM124A available per JM38510/11006

Note 2: LM124 available per JM38510/11005

Connection Diagram (Continued)

Note 3: See STD Mil DWG 5962R99504 for Radiation Tolerant Device

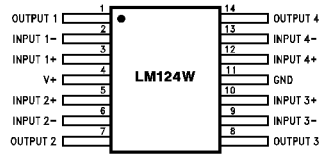

DS009299-33

Order Number LM124AW/883 or LM124W/883
 LM124AWRQML and LM124AWRQMLV(Note 3)
 See NS Package Number W14B
 LM124AWGRQML and LM124AWGRQMLV(Note 3)
 See NS Package Number WG14A

Absolute Maximum Ratings (Note 12)

If Military/Aerospace specified devices are required, please contact the National Semiconductor Sales Office/Distributors for availability and specifications.

	LM124/LM224/LM324 LM124A/LM224A/LM324A	LM2902
Supply Voltage, V^+	32V	26V
Differential Input Voltage	32V	26V
Input Voltage	-0.3V to +32V	-0.3V to +26V
Input Current ($V_{IN} < -0.3V$) (Note 6)	50 mA	50 mA
Power Dissipation (Note 4)		
Molded DIP	1130 mW	1130 mW
Cavity DIP	1260 mW	1260 mW
Small Outline Package	800 mW	800 mW
Output Short-Circuit to GND (One Amplifier) (Note 5) $V^+ \leq 15V$ and $T_A = 25^\circ C$	Continuous	Continuous
Operating Temperature Range		-40°C to +85°C
LM324/LM324A	0°C to +70°C	
LM224/LM224A	-25°C to +85°C	
LM124/LM124A	-55°C to +125°C	
Storage Temperature Range	-65°C to +150°C	-65°C to +150°C
Lead Temperature (Soldering, 10 seconds)	260°C	260°C
Soldering Information		
Dual-In-Line Package		
Soldering (10 seconds)	260°C	260°C
Small Outline Package		
Vapor Phase (60 seconds)	215°C	215°C
Infrared (15 seconds)	220°C	220°C
See AN-450 "Surface Mounting Methods and Their Effect on Product Reliability" for other methods of soldering surface mount devices.		
ESD Tolerance (Note 13)	250V	250V

Electrical Characteristics

$V^+ = +5.0V$, (Note 7), unless otherwise stated

Parameter	Conditions	LM124A			LM224A			LM324A			Units
		Min	Typ	Max	Min	Typ	Max	Min	Typ	Max	
Input Offset Voltage	(Note 8) $T_A = 25^\circ C$		1	2		1	3		2	3	mV
Input Bias Current (Note 9)	$I_{IN(+)}$ or $I_{IN(-)}$, $V_{CM} = 0V$, $T_A = 25^\circ C$		20	50		40	80		45	100	nA
Input Offset Current	$I_{IN(+)}$ or $I_{IN(-)}$, $V_{CM} = 0V$, $T_A = 25^\circ C$		2	10		2	15		5	30	nA
Input Common-Mode Voltage Range (Note 10)	$V^+ = 30V$, (LM2902, $V^+ = 26V$), $T_A = 25^\circ C$	0		$V^+ - 1.5$	0		$V^+ - 1.5$	0		$V^+ - 1.5$	V
Supply Current	Over Full Temperature Range $R_L = \infty$ On All Op Amps $V^+ = 30V$ (LM2902 $V^+ = 26V$) $V^+ = 5V$		1.5	3		1.5	3		1.5	3	mA
			0.7	1.2		0.7	1.2		0.7	1.2	
Large Signal Voltage Gain	$V^+ = 15V$, $R_L \geq 2k\Omega$, ($V_O = 1V$ to $11V$), $T_A = 25^\circ C$	50		100	50		100	25		100	V/mV
Common-Mode Rejection Ratio	DC, $V_{CM} = 0V$ to $V^+ - 1.5V$, $T_A = 25^\circ C$	70		85	70		85	65		85	dB

Electrical Characteristics (Continued)												
V ⁺ = +5.0V, (Note 7), unless otherwise stated												
Parameter	Conditions	LM124A			LM224A			LM324A			Units	
		Min	Typ	Max	Min	Typ	Max	Min	Typ	Max		
Power Supply Rejection Ratio	V ⁺ = 5V to 30V (LM2902, V ⁺ = 5V to 26V), T _A = 25°C	65	100		65	100		65	100		dB	
Amplifier-to-Amplifier Coupling (Note 11)	f = 1 kHz to 20 kHz, T _A = 25°C (Input Referred)		-120			-120			-120		dB	
Output Current	Source	V _{IN⁺} = 1V, V _{IN⁻} = 0V, V ⁺ = 15V, V _O = 2V, T _A = 25°C	20	40		20	40		20	40	mA	
	Sink	V _{IN⁻} = 1V, V _{IN⁺} = 0V, V ⁺ = 15V, V _O = 2V, T _A = 25°C	10	20		10	20		10	20		
		V _{IN⁻} = 1V, V _{IN⁺} = 0V, V ⁺ = 15V, V _O = 200 mV, T _A = 25°C	12	50		12	50		12	50	μA	
Short Circuit to Ground	(Note 5) V ⁺ = 15V, T _A = 25°C		40	60		40	60		40	60	mA	
Input Offset Voltage	(Note 8)			4			4			5	mV	
Input Offset Voltage Drift	R _S = 0Ω		7	20		7	20		7	30	μV/°C	
Input Offset Current	I _{IN(+)} - I _{IN(-)} , V _{CM} = 0V			30			30			75	nA	
Input Offset Current Drift	R _S = 0Ω		10	200		10	200		10	300	pA/°C	
Input Bias Current	I _{IN(+)} or I _{IN(-)}		40	100		40	100		40	200	nA	
Input Common-Mode Voltage Range (Note 10)	V ⁺ = +30V (LM2902, V ⁺ = 26V)	0		V ⁺ -2	0		V ⁺ -2	0		V ⁺ -2	V	
Large Signal Voltage Gain	V ⁺ = +15V (V _O Swing = 1V to 11V) R _L ≥ 2 kΩ	25			25			15			V/mV	
Output Voltage Swing	V _{OH}	V ⁺ = 30V (LM2902, V ⁺ = 26V)		R _L = 2 kΩ	26		26		R _L = 10 kΩ	26	V	
	V _{OL}	V ⁺ = 5V, R _L = 10 kΩ	27	28		27	28		27	28		
			5	20		5	20		5	20	mV	
Output Current	Source	V _O = 2V	V _{IN⁺} = +1V, V _{IN⁻} = 0V, V ⁺ = 15V	10	20		10	20		10	20	mA
	Sink		V _{IN⁻} = +1V, V _{IN⁺} = 0V, V ⁺ = 15V	10	15		5	8		5	8	

Electrical Characteristics											
V ⁺ = +5.0V, (Note 7), unless otherwise stated											
Parameter	Conditions	LM124/LM224			LM324			LM2902			Units
		Min	Typ	Max	Min	Typ	Max	Min	Typ	Max	
Input Offset Voltage	(Note 8) T _A = 25°C		2	5		2	7		2	7	mV
Input Bias Current (Note 9)	I _{IN(+)} or I _{IN(-)} , V _{CM} = 0V, T _A = 25°C		45	150		45	250		45	250	nA
Input Offset Current	I _{IN(+)} or I _{IN(-)} , V _{CM} = 0V, T _A = 25°C		3	30		5	50		5	50	nA
Input Common-Mode Voltage Range (Note 10)	V ⁺ = 30V, (LM2902, V ⁺ = 26V), T _A = 25°C	0		V ⁺ -1.5	0		V ⁺ -1.5	0		V ⁺ -1.5	V
Supply Current	Over Full Temperature Range R _L = ∞ On All Op Amps V ⁺ = 30V (LM2902 V ⁺ = 26V) V ⁺ = 5V		1.5	3		1.5	3		1.5	3	mA
			0.7	1.2		0.7	1.2		0.7	1.2	
Large Signal Voltage Gain	V ⁺ = 15V, R _L ≥ 2kΩ, (V _O = 1V to 11V), T _A = 25°C	50	100		25	100		25	100		V/mV

Electrical Characteristics (Continued)

$V^+ = +5.0V$, (Note 7), unless otherwise stated

Parameter	Conditions	LM124/LM224			LM324			LM2902			Units	
		Min	Typ	Max	Min	Typ	Max	Min	Typ	Max		
Common-Mode Rejection Ratio	DC, $V_{CM} = 0V$ to $V^+ - 1.5V$, $T_A = 25^\circ C$	70	85		65	85		50	70		dB	
Power Supply Rejection Ratio	$V^+ = 5V$ to $30V$ (LM2902, $V^+ = 5V$ to $26V$), $T_A = 25^\circ C$	65	100		65	100		50	100		dB	
Amplifier-to-Amplifier Coupling (Note 11)	$f = 1$ kHz to 20 kHz, $T_A = 25^\circ C$ (Input Referred)		-120			-120			-120		dB	
Output Current	Source	$V_{IN}^+ = 1V$, $V_{IN}^- = 0V$, $V^+ = 15V$, $V_O = 2V$, $T_A = 25^\circ C$		20	40		20	40		20	40	mA
	Sink	$V_{IN}^- = 1V$, $V_{IN}^+ = 0V$, $V^+ = 15V$, $V_O = 2V$, $T_A = 25^\circ C$		10	20		10	20		10	20	
		$V_{IN}^- = 1V$, $V_{IN}^+ = 0V$, $V^+ = 15V$, $V_O = 200$ mV, $T_A = 25^\circ C$		12	50		12	50		12	50	μA
Short Circuit to Ground	(Note 5) $V^+ = 15V$, $T_A = 25^\circ C$		40	60		40	60		40	60	mA	
Input Offset Voltage	(Note 8)			7			9			10	mV	
Input Offset Voltage Drift	$R_S = 0\Omega$			7			7			7	$\mu V/^\circ C$	
Input Offset Current	$I_{IN(+)} - I_{IN(-)}$, $V_{CM} = 0V$			100			150			45	200	nA
Input Offset Current Drift	$R_S = 0\Omega$			10			10			10	$pA/^\circ C$	
Input Bias Current	$I_{IN(+)}$ or $I_{IN(-)}$		40	300		40	500		40	500	nA	
Input Common-Mode Voltage Range (Note 10)	$V^+ = +30V$ (LM2902, $V^+ = 26V$)	0		$V^+ - 2$	0		$V^+ - 2$	0		$V^+ - 2$	V	
Large Signal Voltage Gain	$V^+ = +15V$ (V_O Swing = $1V$ to $11V$) $R_L \geq 2$ k Ω	25			15			15			V/mV	
Output Voltage Swing	V_{OH}	$V^+ = 30V$ (LM2902, $V^+ = 26V$)		$R_L = 2$ k Ω		26		26		22		V
	V_{OL}	$V^+ = 5V$, $R_L = 10$ k Ω		5	20		5	20		5	100	mV
Output Current	Source	$V_O = 2V$		$V_{IN}^+ = +1V$, $V_{IN}^- = 0V$, $V^+ = 15V$		10	20		10	20		mA
	Sink			$V_{IN}^- = +1V$, $V_{IN}^+ = 0V$, $V^+ = 15V$		5	8		5	8		

Note 4: For operating at high temperatures, the LM324/LM324A/LM2902 must be derated based on a $+125^\circ C$ maximum junction temperature and a thermal resistance of $88^\circ C/W$ which applies for the device soldered in a printed circuit board, operating in a still air ambient. The LM224/LM224A and LM124/LM124A can be derated based on a $+150^\circ C$ maximum junction temperature. The dissipation is the total of all four amplifiers—use external resistors, where possible, to allow the amplifier to saturate or to reduce the power which is dissipated in the integrated circuit.

Note 5: Short circuits from the output to V^+ can cause excessive heating and eventual destruction. When considering short circuits to ground, the maximum output current is approximately 40 mA independent of the magnitude of V^+ . At values of supply voltage in excess of $+15V$, continuous short-circuits can exceed the power dissipation ratings and cause eventual destruction. Destructive dissipation can result from simultaneous shorts on all amplifiers.

Note 6: This input current will only exist when the voltage at any of the input leads is driven negative. It is due to the collector-base junction of the input PNP transistors becoming forward biased and thereby acting as input diode clamps. In addition to this diode action, there is also lateral NPN parasitic transistor action on the IC chip. This transistor action can cause the output voltages of the op amps to go to the V^+ voltage level (or to ground for a large overdrive) for the time duration that an input is driven negative. This is not destructive and normal output states will re-establish when the input voltage, which was negative, again returns to a value greater than $-0.3V$ (at $25^\circ C$).

Note 7: These specifications are limited to $-55^\circ C \leq T_A \leq +125^\circ C$ for the LM124/LM124A. With the LM224/LM224A, all temperature specifications are limited to $-25^\circ C \leq T_A \leq +85^\circ C$, the LM324/LM324A temperature specifications are limited to $0^\circ C \leq T_A \leq +70^\circ C$, and the LM2902 specifications are limited to $-40^\circ C \leq T_A \leq +85^\circ C$.

Note 8: $V_O \cong 1.4V$, $R_S = 0\Omega$ with V^+ from $5V$ to $30V$; and over the full input common-mode range ($0V$ to $V^+ - 1.5V$) for LM2902, V^+ from $5V$ to $26V$.

Note 9: The direction of the input current is out of the IC due to the PNP input stage. This current is essentially constant, independent of the state of the output so no loading change exists on the input lines.

Note 10: The input common-mode voltage of either input signal voltage should not be allowed to go negative by more than $0.3V$ (at $25^\circ C$). The upper end of the common-mode voltage range is $V^+ - 1.5V$ (at $25^\circ C$), but either or both inputs can go to $+32V$ without damage ($+26V$ for LM2902), independent of the magnitude of V^+ .

Note 11: Due to proximity of external components, insure that coupling is not originating via stray capacitance between these external parts. This typically can be detected as this type of capacitance increases at higher frequencies.

Note 12: Refer to RETS124AX for LM124A military specifications and refer to RETS124X for LM124 military specifications.

Electrical Characteristics (Continued)

Note 13: Human body model, 1.5 kΩ in series with 100 pF.

Schematic Diagram (Each Amplifier)

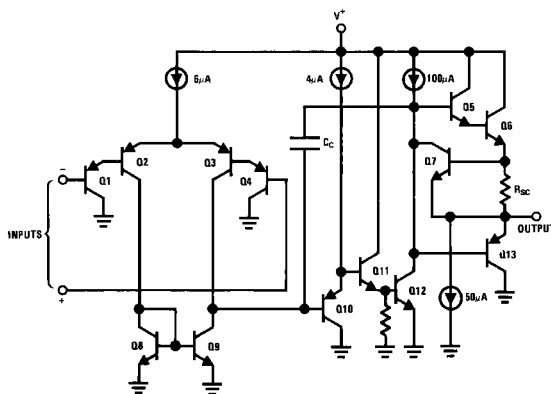

DS009299-2

Typical Performance Characteristics

Input Voltage Range

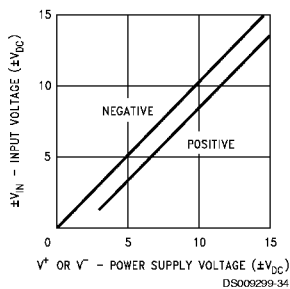

Input Current

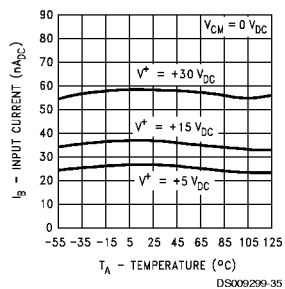

Supply Current

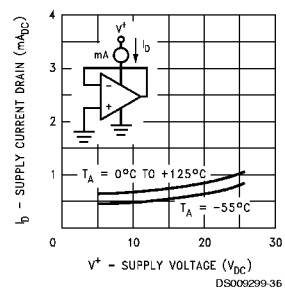

Voltage Gain

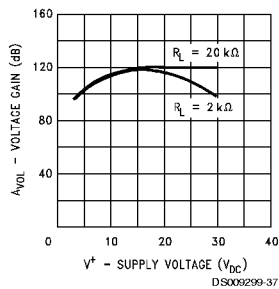

Open Loop Frequency Response

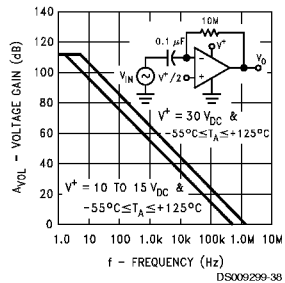

Common Mode Rejection Ratio

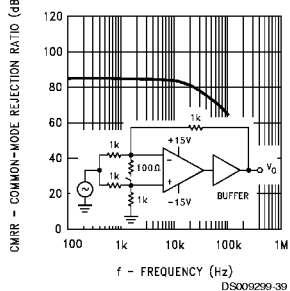

Typical Performance Characteristics (Continued)

Voltage Follower Pulse Response

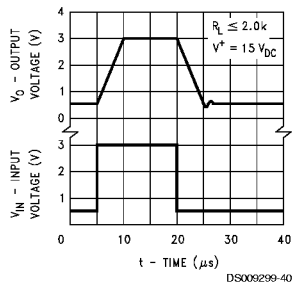

Voltage Follower Pulse Response (Small Signal)

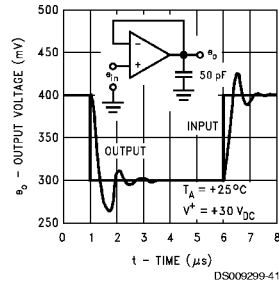

Large Signal Frequency Response

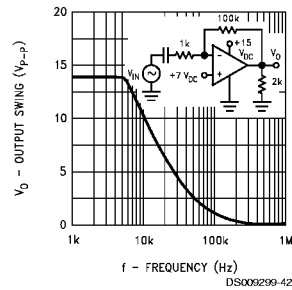

Output Characteristics Current Sourcing

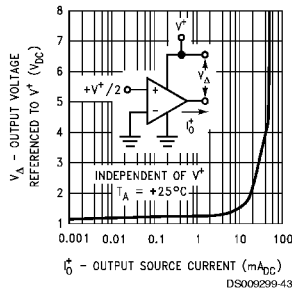

Output Characteristics Current Sinking

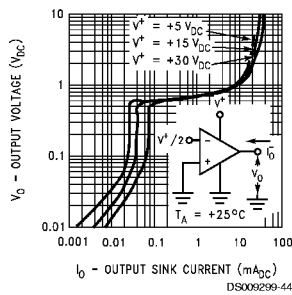

Current Limiting

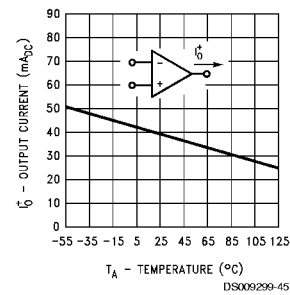

Input Current (LM2902 only)

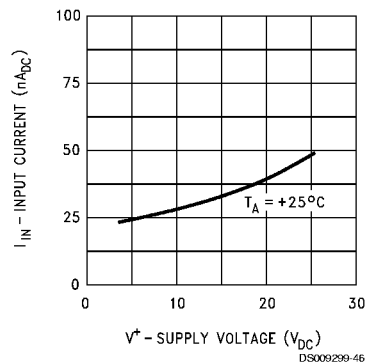

Voltage Gain (LM2902 only)

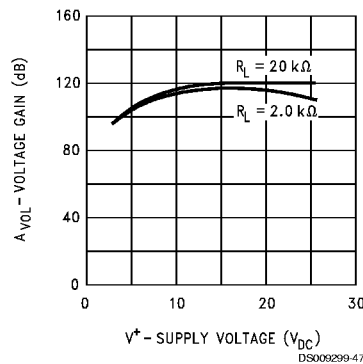

Application Hints

The LM124 series are op amps which operate with only a single power supply voltage, have true-differential inputs, and remain in the linear mode with an input common-mode voltage of 0 V_{DC}. These amplifiers operate over a wide range of power supply voltage with little change in performance characteristics. At 25°C amplifier operation is possible down to a minimum supply voltage of 2.3 V_{DC}.

The pinouts of the package have been designed to simplify PC board layouts. Inverting inputs are adjacent to outputs for all of the amplifiers and the outputs have also been placed at the corners of the package (pins 1, 7, 8, and 14).

Precautions should be taken to insure that the power supply for the integrated circuit never becomes reversed in polarity or that the unit is not inadvertently installed backwards in a

Application Hints (Continued)

test socket as an unlimited current surge through the resulting forward diode within the IC could cause fusing of the internal conductors and result in a destroyed unit.

Large differential input voltages can be easily accommodated and, as input differential voltage protection diodes are not needed, no large input currents result from large differential input voltages. The differential input voltage may be larger than V^+ without damaging the device. Protection should be provided to prevent the input voltages from going negative more than $-0.3 V_{DC}$ (at 25°C). An input clamp diode with a resistor to the IC input terminal can be used.

To reduce the power supply drain, the amplifiers have a class A output stage for small signal levels which converts to class B in a large signal mode. This allows the amplifiers to both source and sink large output currents. Therefore both NPN and PNP external current boost transistors can be used to extend the power capability of the basic amplifiers. The output voltage needs to raise approximately 1 diode drop above ground to bias the on-chip vertical PNP transistor for output current sinking applications.

For ac applications, where the load is capacitively coupled to the output of the amplifier, a resistor should be used, from the output of the amplifier to ground to increase the class A bias current and prevent crossover distortion.

Where the load is directly coupled, as in dc applications, there is no crossover distortion.

Capacitive loads which are applied directly to the output of the amplifier reduce the loop stability margin. Values of 50 pF can be accommodated using the worst-case

non-inverting unity gain connection. Large closed loop gains or resistive isolation should be used if larger load capacitance must be driven by the amplifier.

The bias network of the LM124 establishes a drain current which is independent of the magnitude of the power supply voltage over the range of from $3 V_{DC}$ to $30 V_{DC}$.

Output short circuits either to ground or to the positive power supply should be of short time duration. Units can be destroyed, not as a result of the short circuit current causing metal fusing, but rather due to the large increase in IC chip dissipation which will cause eventual failure due to excessive junction temperatures. Putting direct short-circuits on more than one amplifier at a time will increase the total IC power dissipation to destructive levels, if not properly protected with external dissipation limiting resistors in series with the output leads of the amplifiers. The larger value of output source current which is available at 25°C provides a larger output current capability at elevated temperatures (see typical performance characteristics) than a standard IC op amp.

The circuits presented in the section on typical applications emphasize operation on only a single power supply voltage. If complementary power supplies are available, all of the standard op amp circuits can be used. In general, introducing a pseudo-ground (a bias voltage reference of $V^+/2$) will allow operation above and below this value in single power supply systems. Many application circuits are shown which take advantage of the wide input common-mode voltage range which includes ground. In most cases, input biasing is not required and input voltages which range to ground can easily be accommodated.

Typical Single-Supply Applications ($V^+ = 5.0 V_{DC}$)

Non-Inverting DC Gain ($0V$ Input = $0V$ Output)

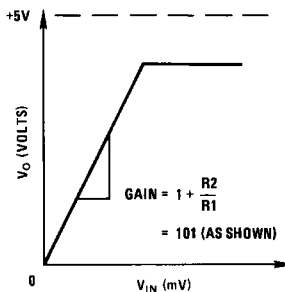
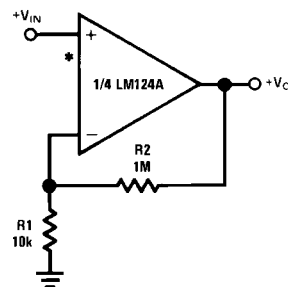

DS009299-5

*R not needed due to temperature independent I_{IN}

Typical Single-Supply Applications ($V^+ = 5.0 V_{DC}$) (Continued)

DC Summing Amplifier
 ($V_{IN'S} \geq 0 V_{DC}$ and $V_O \geq V_{DC}$)

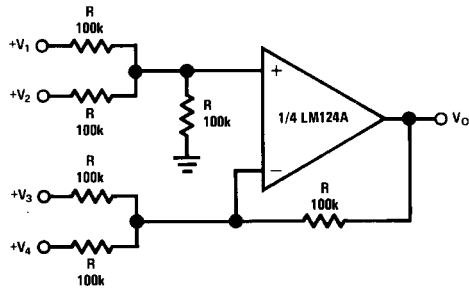

DS009299-6

Where: $V_O = V_1 + V_2 - V_3 - V_4$
 ($V_1 + V_2 \geq (V_3 + V_4)$ to keep $V_O > 0 V_{DC}$)

Power Amplifier

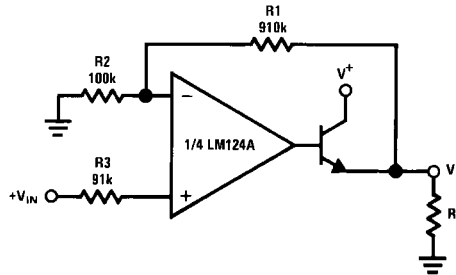

DS009299-7

$V_O = 0 V_{DC}$ for $V_{IN} = 0 V_{DC}$
 $A_V = 10$

LED Driver

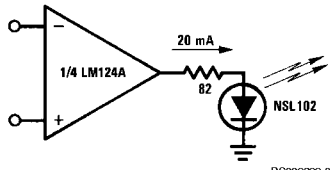

DS009299-8

"BI-QUAD" RC Active Bandpass Filter

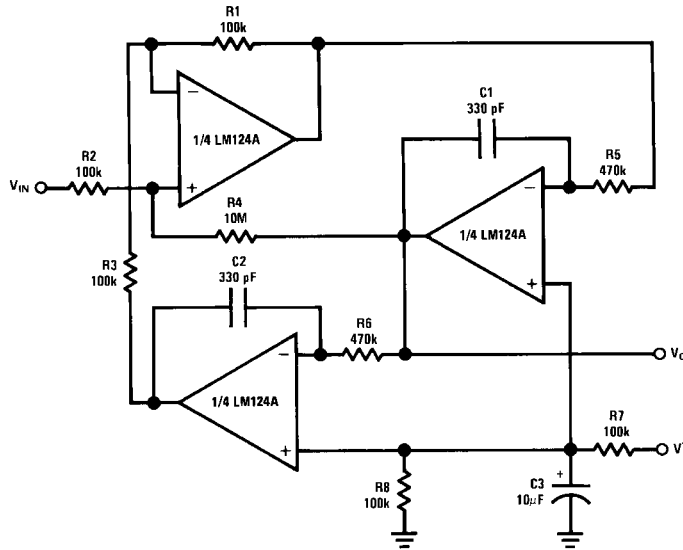

DS009299-9

$f_o = 1 \text{ kHz}$
 $Q = 50$
 $A_V = 100 \text{ (40 dB)}$

Typical Single-Supply Applications $(V^+ = 5.0 V_{DC})$ (Continued)

Fixed Current Sources

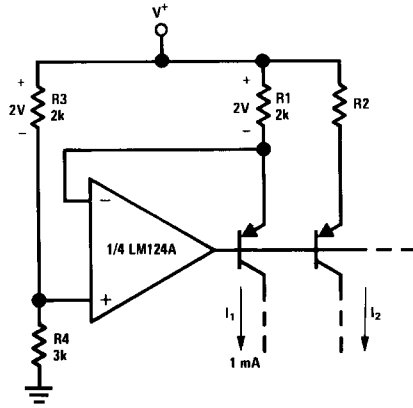

DS009299-10

$$I_2 = \left(\frac{R1}{R2}\right) I_1$$

Lamp Driver

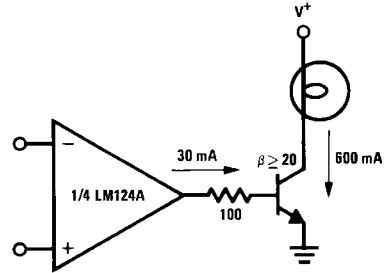

DS009299-11

Current Monitor

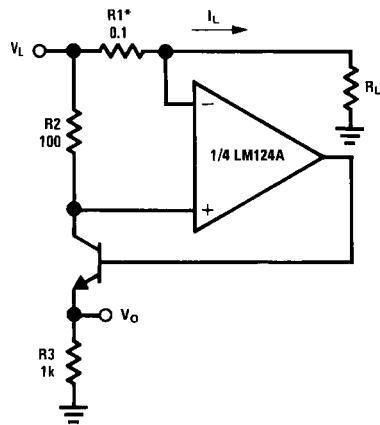

DS009299-12

$$V_O = \frac{1V(I_L)}{1A}$$

$$V_L \leq V^+ - 2V$$

*(Increase R1 for I_L small)

Driving TTL

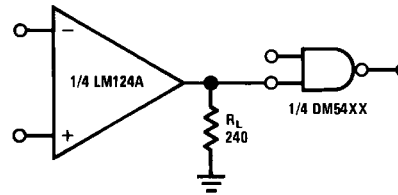

DS009299-13

Typical Single-Supply Applications $(V^+ = 5.0 V_{DC})$ (Continued)

LM124/LM224/LM324/LM2902

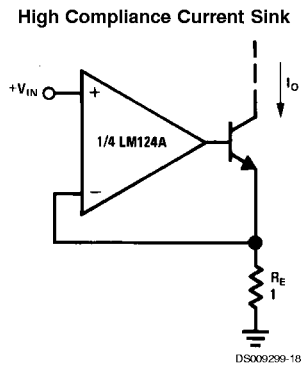
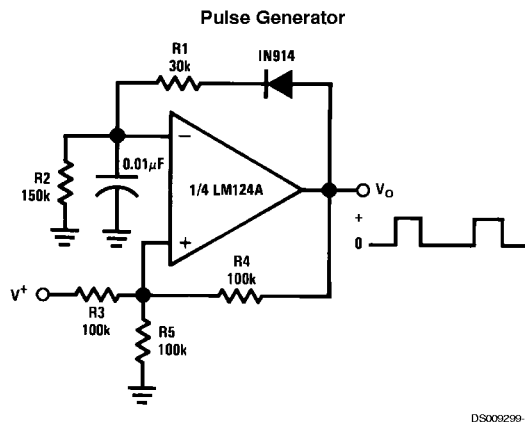
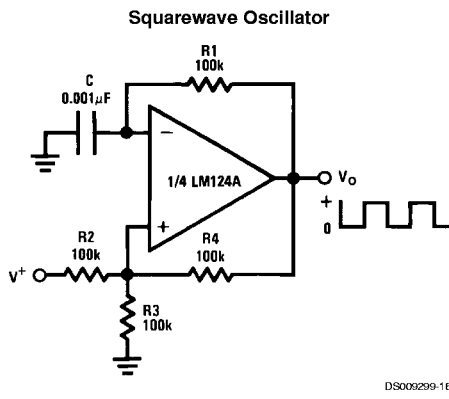
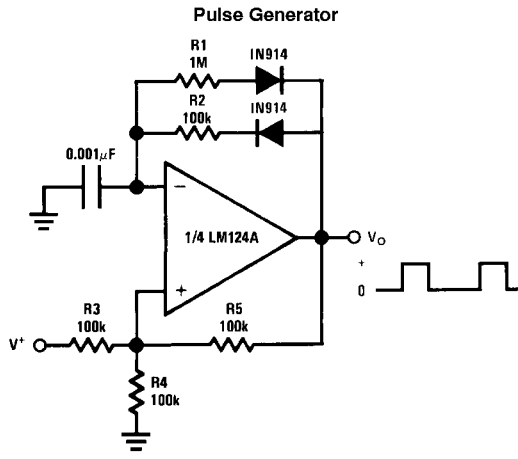
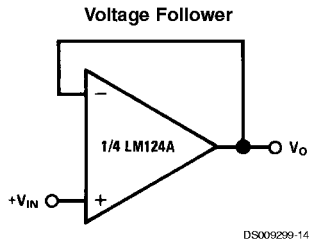

$I_O = 1 \text{ amp/volt } V_{IN}$
 (Increase R_E for I_O small)

Typical Single-Supply Applications ($V^+ = 5.0 V_{DC}$) (Continued)

Low Drift Peak Detector

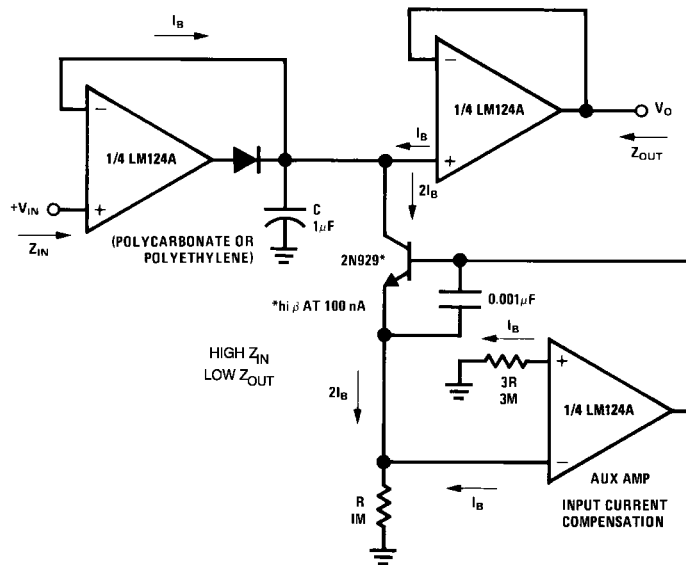

DS009299-19

Comparator with Hysteresis

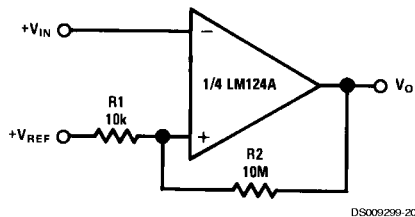

Ground Referencing a Differential Input Signal

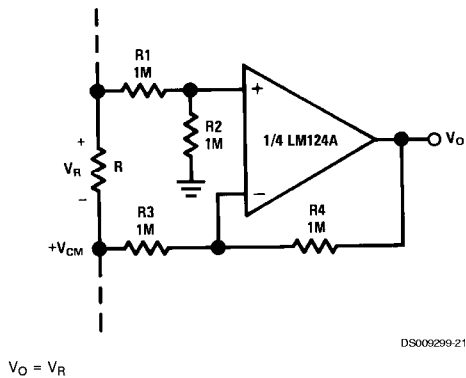

Typical Single-Supply Applications ($V^+ = 5.0 V_{DC}$) (Continued)

Voltage Controlled Oscillator Circuit

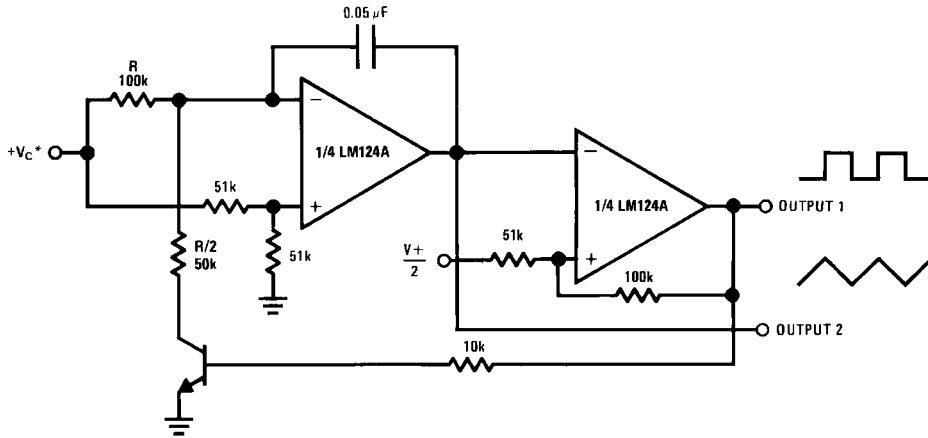

DS009299-22

*Wide control voltage range: $0 V_{DC} \leq V_C \leq 2 (V^+ - 1.5 V_{DC})$

Photo Voltaic-Cell Amplifier

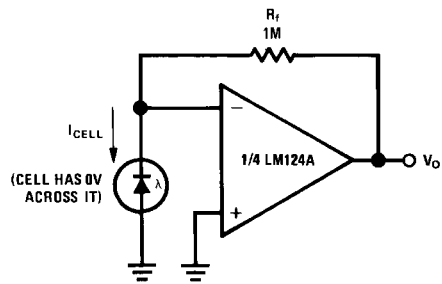

DS009299-23

AC Coupled Inverting Amplifier

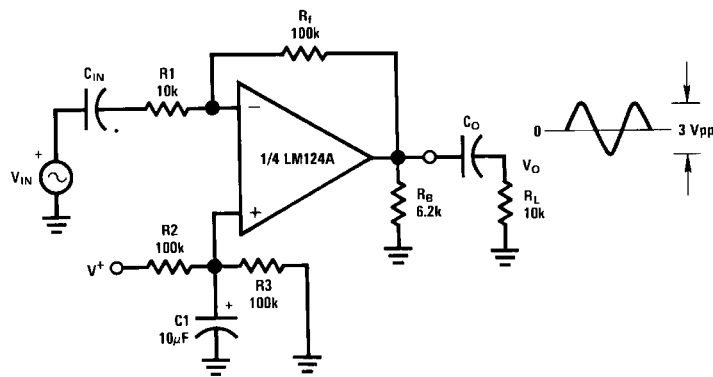

DS009299-24

$A_V = \frac{R_f}{R_1}$ (As shown, $A_V = 10$)

Typical Single-Supply Applications ($V^+ = 5.0 V_{DC}$) (Continued)

AC Coupled Non-Inverting Amplifier

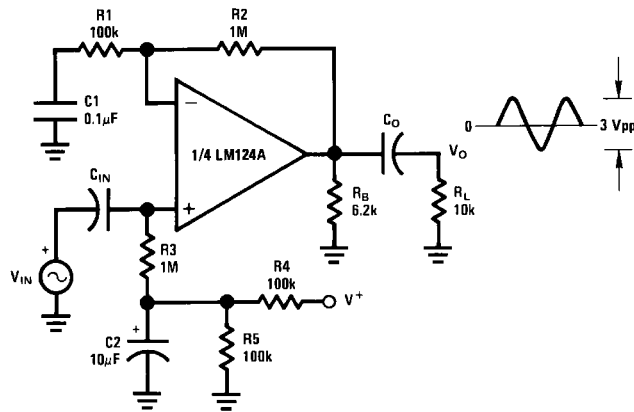

DS009299-25

$$A_V = 1 + \frac{R_2}{R_1}$$

$A_V = 11$ (As shown)

DC Coupled Low-Pass RC Active Filter

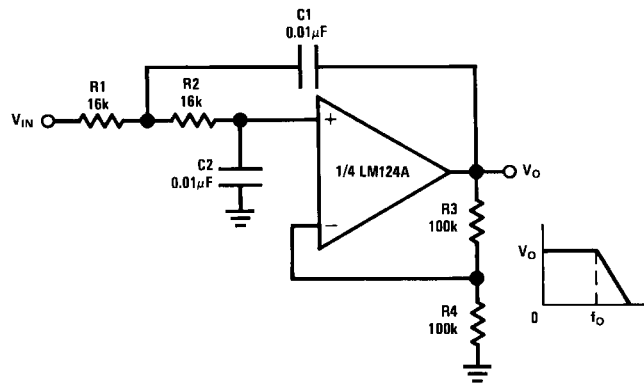

DS009299-26

$f_o = 1 \text{ kHz}$
 $Q = 1$
 $A_V = 2$

Typical Single-Supply Applications ($V^+ = 5.0 V_{DC}$) (Continued)

High Input Z, DC Differential Amplifier

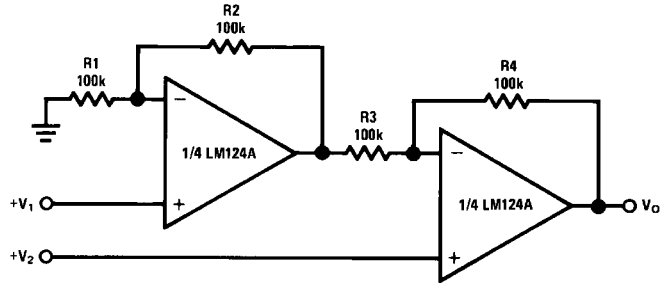

DS009299-27

For $\frac{R1}{R2} = \frac{R4}{R3}$ (CMRR depends on this resistor ratio match)

$$V_O = 1 + \frac{R4}{R3}(V_2 - V_1)$$

As shown: $V_O = 2(V_2 - V_1)$

High Input Z Adjustable-Gain DC Instrumentation Amplifier

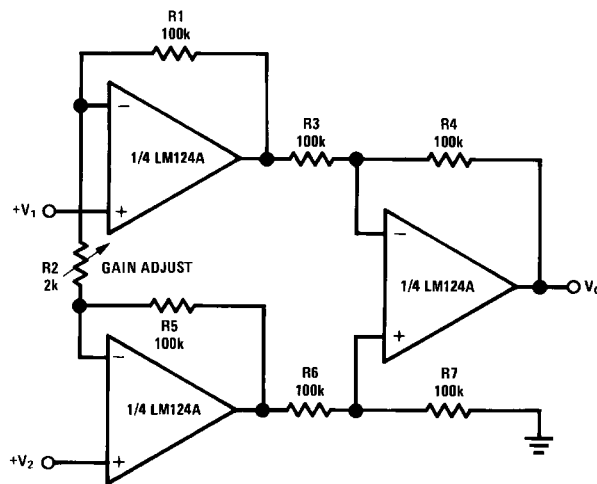

DS009299-28

If $R1 = R5$ & $R3 = R4 = R6 = R7$ (CMRR depends on match)

$$V_O = 1 + \frac{2R1}{R2}(V_2 - V_1)$$

As shown $V_O = 101(V_2 - V_1)$

Typical Single-Supply Applications ($V^+ = 5.0 V_{DC}$) (Continued)

Using Symmetrical Amplifiers to Reduce Input Current (General Concept)

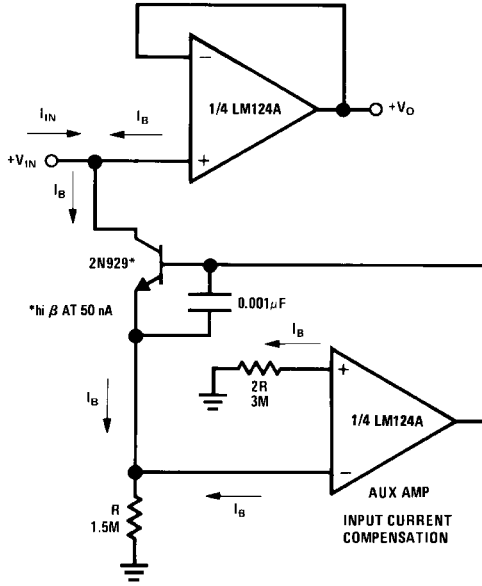

DS009299-29

Bridge Current Amplifier

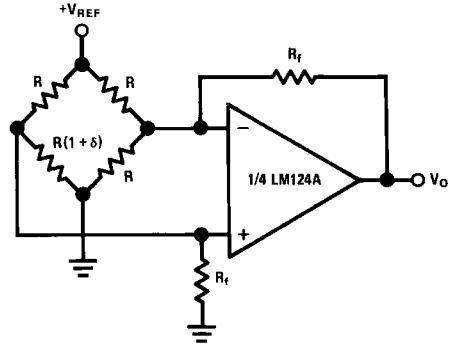

DS009299-30

For $\delta \ll 1$ and $R_f \gg R$
 $V_O \approx V_{REF} \left(\frac{\delta}{2} \right) \frac{R_f}{R}$

Bandpass Active Filter

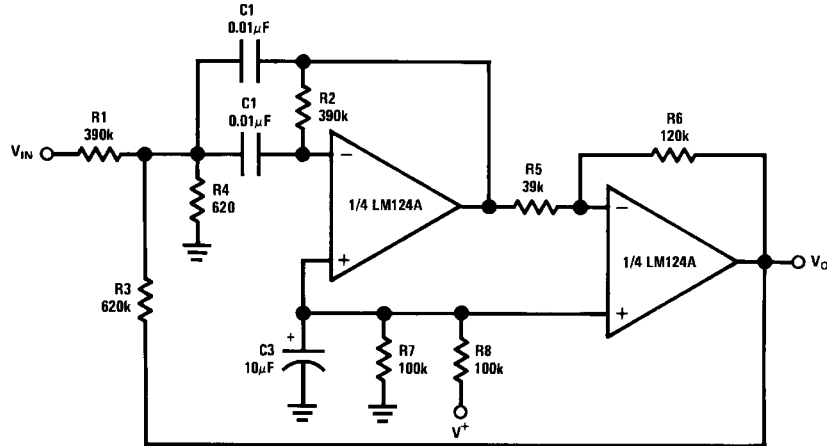

DS009299-31

$f_O = 1 \text{ kHz}$
 $Q = 25$

Physical Dimensions inches (millimeters) unless otherwise noted

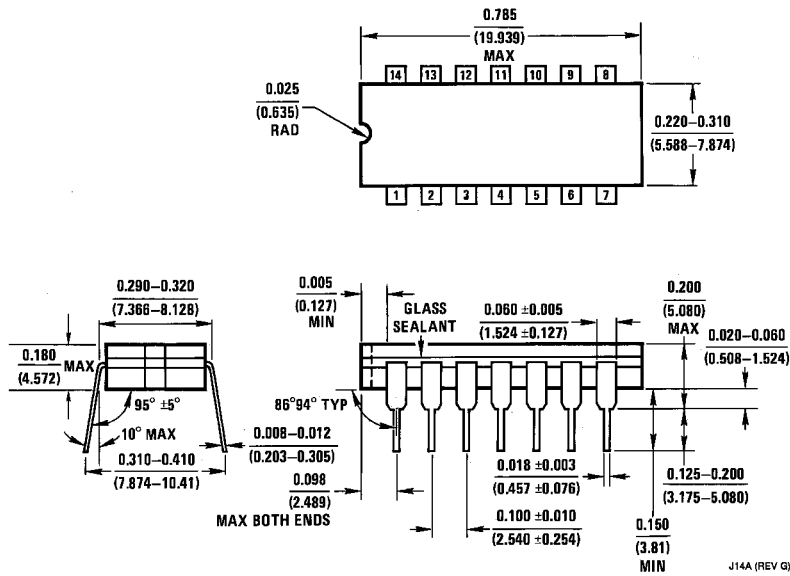

Ceramic Dual-In-Line Package (J)

Order Number LM124J, LM124AJ, LM124AJ/883, LM124J/883, LM224J, LM224AJ or LM324J
NS Package Number J14A

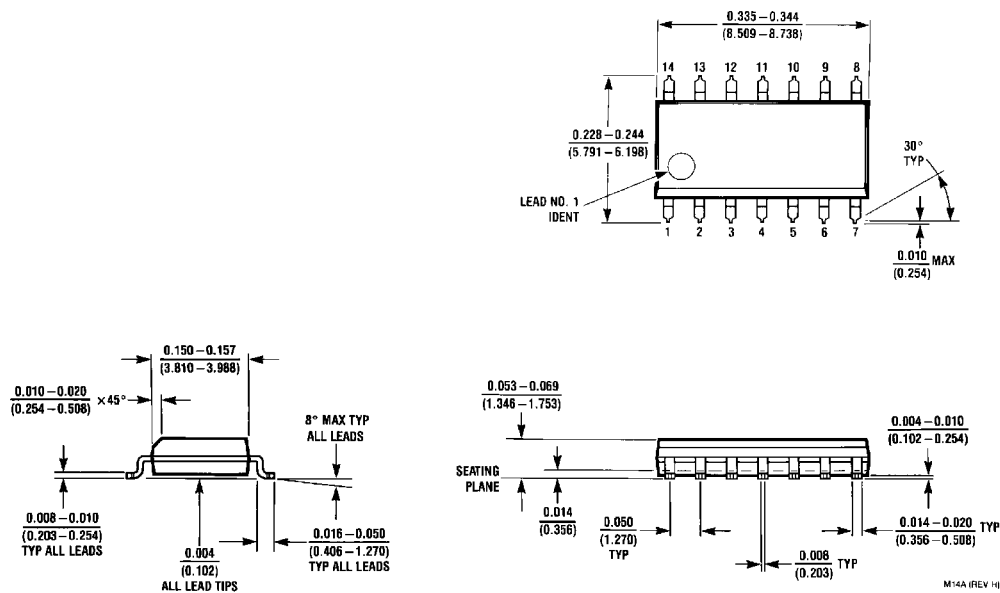

S.O. Package (M)

Order Number LM324M, LM324AM or LM2902M
NS Package Number M14A

