

NA 系列
SERIES

85°C 双极性小型化标准品 85°C Bi-polar Miniaturized

◆ 特 长 / FEATURES

- RoHS指令对应品。
RoHS compliance.

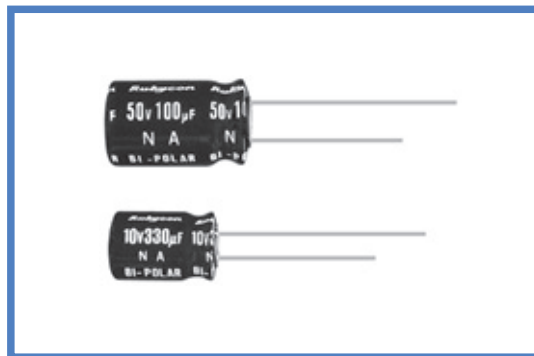

◆ 规格表 / SPECIFICATIONS

项 目 Items	特 性 Characteristics																														
工作温度范围 Category Temperature Range	-40 ~ +85°C																														
额定电压范围 Rated Voltage Range	6.3 ~ 100V.DC																														
静电容量允许差 Capacitance Tolerance	±20% (20°C, 120Hz)																														
漏 电 流 Leakage Current(MAX)	小于 $I=0.03CV$ 和 $3\mu A$ 中的较大值 (施加额定电压5分钟后) $I=0.03CV$ or $3\mu A$ whichever is greater. (After 5 minutes application of rated voltage) I=漏电流 (µA) C=静电容量 (µF) V=额定电压 (V) Leakage Current Capacitance Rated Voltage																														
损失角正切值 (tan δ) Dissipation Factor(MAX)	<table border="1"> <tr> <td>额定电压 (V) Rated Voltage</td> <td>6.3</td> <td>10</td> <td>16</td> <td>25</td> <td>35</td> <td>50</td> <td>63</td> <td>100</td> <td>(20°C, 120Hz)</td> </tr> <tr> <td>tan δ</td> <td>0.25</td> <td>0.25</td> <td>0.20</td> <td>0.20</td> <td>0.15</td> <td>0.15</td> <td>0.15</td> <td>0.15</td> <td></td> </tr> </table>	额定电压 (V) Rated Voltage	6.3	10	16	25	35	50	63	100	(20°C, 120Hz)	tan δ	0.25	0.25	0.20	0.20	0.15	0.15	0.15	0.15											
额定电压 (V) Rated Voltage	6.3	10	16	25	35	50	63	100	(20°C, 120Hz)																						
tan δ	0.25	0.25	0.20	0.20	0.15	0.15	0.15	0.15																							
耐 久 性 Endurance	<p>在85°C中, 每250小时将极性反转一次, 不超过额定电压的范围施加额定纹波电流, 连续加载2000小时后, 满足以下各项要求。 After applying rated voltage with rated ripple current for 2000hrs at 85°C, (The polarity shall be reversed every 250hrs.), the capacitors shall meet the following requirements.</p> <table border="1"> <tr> <td>静电容量变化率 Capacitance Change</td> <td>初期值的±25%以内 Within ±25% of the initial value.</td> </tr> <tr> <td>损失角正切值 Dissipation Factor</td> <td>规格值的200%以下 Not more than 200% of the specified value.</td> </tr> <tr> <td>漏 电 流 Leakage Current</td> <td>规格值以下 Not more than the specified value.</td> </tr> </table>	静电容量变化率 Capacitance Change	初期值的±25%以内 Within ±25% of the initial value.	损失角正切值 Dissipation Factor	规格值的200%以下 Not more than 200% of the specified value.	漏 电 流 Leakage Current	规格值以下 Not more than the specified value.																								
静电容量变化率 Capacitance Change	初期值的±25%以内 Within ±25% of the initial value.																														
损失角正切值 Dissipation Factor	规格值的200%以下 Not more than 200% of the specified value.																														
漏 电 流 Leakage Current	规格值以下 Not more than the specified value.																														
低 温 特 性 Low Temperature Stability (阻抗比) Impedance Ratio(MAX)	<table border="1"> <tr> <td>额定电压 (V) Rated Voltage</td> <td>6.3</td> <td>10</td> <td>16</td> <td>25</td> <td>35</td> <td>50</td> <td>63</td> <td>100</td> <td>(120Hz)</td> </tr> <tr> <td>Z(-25°C)/Z(20°C)</td> <td>6</td> <td>4</td> <td>4</td> <td>3</td> <td>2</td> <td>2</td> <td>2</td> <td>2</td> <td></td> </tr> <tr> <td>Z(-40°C)/Z(20°C)</td> <td>12</td> <td>10</td> <td>8</td> <td>6</td> <td>4</td> <td>4</td> <td>4</td> <td>3</td> <td></td> </tr> </table>	额定电压 (V) Rated Voltage	6.3	10	16	25	35	50	63	100	(120Hz)	Z(-25°C)/Z(20°C)	6	4	4	3	2	2	2	2		Z(-40°C)/Z(20°C)	12	10	8	6	4	4	4	3	
额定电压 (V) Rated Voltage	6.3	10	16	25	35	50	63	100	(120Hz)																						
Z(-25°C)/Z(20°C)	6	4	4	3	2	2	2	2																							
Z(-40°C)/Z(20°C)	12	10	8	6	4	4	4	3																							

◆ 纹波电流修正系数 / MULTIPLIER FOR RIPPLE CURRENT

频率系数 Frequency coefficient

频率 (Hz) Frequency	60(50)	120	500	1k	10k≤
1µF	0.50	1.00	1.20	1.30	1.50
2.2~4.7µF	0.65	1.00	1.20	1.30	1.50
10~47µF	0.80	1.00	1.20	1.30	1.50
100~1000µF	0.80	1.00	1.10	1.15	1.20

◆ 产品型号体系 / PART NUMBER

□□□	NA	□□□□□	□	□□□	□□	D×L
额定电压 Rated Voltage	系列名称 Series	静电容量 Capacitance	静电容量允许差 Capacitance Tolerance	副记号 Option	引线加工记号 Lead Forming	铝壳尺寸 Case Size

◆尺寸图 / DIMENSIONS

(mm)

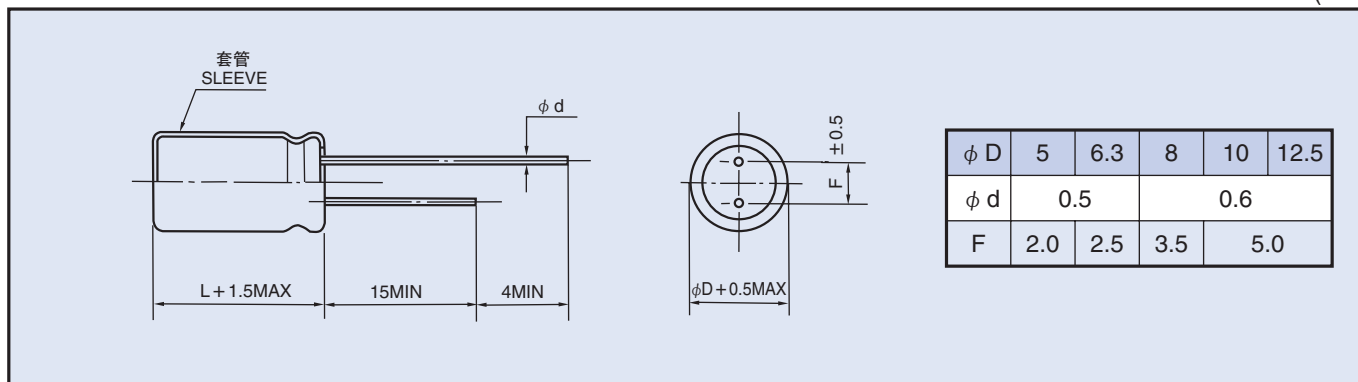

◆标准品一览表 / STANDARD SIZE

Size $\phi D \times L$ (mm), Ripple Current (mA r.m.s./85°C, 120Hz)

额定电压 WV (V.DC) 静电容量 Cap (μF)	6.3 (0J)		10 (1A)		16 (1C)		25 (1E)	
	Size	Ripple	Size	Ripple	Size	Ripple	Size	Ripple
33							5 × 11	77
47					5 × 11	80	6.3 × 11	100
100	5 × 11	100	6.3 × 11	115	6.3 × 11	130	8 × 11.5	175
220	6.3 × 11	160	8 × 11.5	205	8 × 11.5	220	10 × 12.5	295
330	8 × 11.5	225	8 × 11.5	240	10 × 12.5	325	10 × 16	380
470	8 × 11.5	250	10 × 12.5	345	10 × 16	415	10 × 20	510
1000	10 × 16	425	10 × 20	550	12.5 × 20	695		

额定电压 WV (V.DC) 静电容量 Cap (μF)	35 (1V)		50 (1H)		63 (1J)		100 (2A)	
	Size	Ripple	Size	Ripple	Size	Ripple	Size	Ripple
1			5 × 11	12			5 × 11	15
2.2			5 × 11	19			5 × 11	20
3.3			5 × 11	25			5 × 11	27
4.7			5 × 11	35	5 × 11	35	6.3 × 11	37
10			5 × 11	40	6.3 × 11	45	8 × 11.5	65
22	5 × 11	65	6.3 × 11	72	8 × 11.5	82	10 × 12.5	96
33	6.3 × 11	90	6.3 × 11	95	8 × 11.5	100	10 × 16	125
47	6.3 × 11	110	8 × 11.5	130	10 × 12.5	140	10 × 20	165
100	10 × 12.5	220	10 × 16	235	10 × 20	250	12.5 × 25	285
220	10 × 20	390	12.5 × 20	460	12.5 × 25	490		
330	12.5 × 20	540	12.5 × 25	590				
470	12.5 × 25	640						