

DO NOT SCALE FROM THIS PRINT

FIG 1

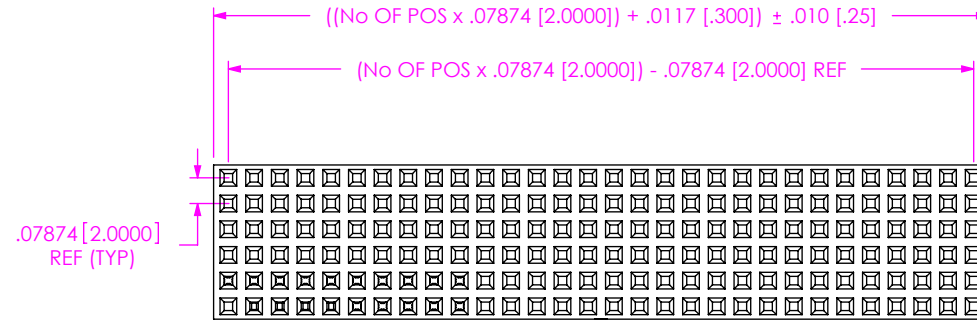

**** -MW OPTION, DO NOT DESIGN IN. SAMTEC WILL ONLY SUPPORT EXISTING BUSINESS 2/07/02.**

POSITION SPECIFICATION

-02 THRU -50 POSITIONS PER ROW (SEE NOTE 1)

LEAD STYLE SPEC

-02: USE C-79-02-X
-03: USE C-79-53-X

PLATING SPECIFICATION

-F: FLASH SELECTIVE, 3 Au / 50 Ni MIN ON CONTACT, MATTE TIN ON TAIL.
-FM: FLASH SELECTIVE, 3 Au / 50 Ni MIN ON CONTACT, MATTE TIN TAIL.
-L: LIGHT SELECTIVE, 10 Au / 50 Ni MIN ON CONTACT, MATTE TIN ON TAIL.
-LM: LIGHT SELECTIVE, 10 Au / 50 Ni MIN ON CONTACT, MATTE TIN TAIL.
-G: GOLD, 20 Au / 50 Ni MIN ON CONTACT, 3 Au / 50 Ni MIN ON TAIL.
-GF: LIGHT GOLD: 15 Au / 50 Ni MIN ON CONTACT, 3 Au / 50 Ni MIN ON TAIL (-02 LEAD STYLE ONLY).
-H: HEAVY GOLD: 30 Au / 50 Ni MIN ON CONTACT, 3 Au / 50 Ni MIN ON TAIL.
-S : SELECTIVE, 30 Au / 50 Ni MIN ON CONTACT, MATTE TIN ON TAIL.
-SM: SELECTIVE: 30 Au / 50Ni MIN ON CONTACT, MATTE TIN ON TAIL.
-M: MEDIUM SELECTIVE, 20 Au / 50 Ni MIN ON CONTACT, MATTE TIN ON TAIL.
-MM: MEDIUM SELECTIVE: 20 Au / 50 Ni MIN ON CONTACT, MATTE TIN ON TAIL.

OPTION

** -MW: METAL WASHER (SEE FIG.2 SHT.2) (5 POS MIN, 30 POS MAX) (USE TMMH-XX-D-XX BODY N/A ON -S ROW SPEC) (.090 [2.29] MIN, .300 [7.62] MAX TAIL FOR -F, -L & -S PLATING) (.090 [2.29] MIN, .482 [12.24] MAX TAIL FOR -G, & -M PLATING)

POLARIZATION OPTION
-XXX: INDICATES POSITION (SEE FIG 3, SHT 2) (USE PK-07)

SPACE OPTION

.309 [7.85] MIN FOR -S, -D, -Q ROWS
.375 [9.53] MIN FOR -T, -5 & -6 ROWS
"B" MAX (SEE TABLE 1)

ROW SPECIFICATION

-S: SINGLE (SEE -S)
-D: DOUBLE (SEE -D)
-T: TRIPLE (SEE -T & SEE NOTE 4)
-Q: QUAD (SEE -Q)
-5: FIVE (SEE -5 & SEE NOTE 4)
-6: SIX (SEE -6 AND SEE NOTE 4)

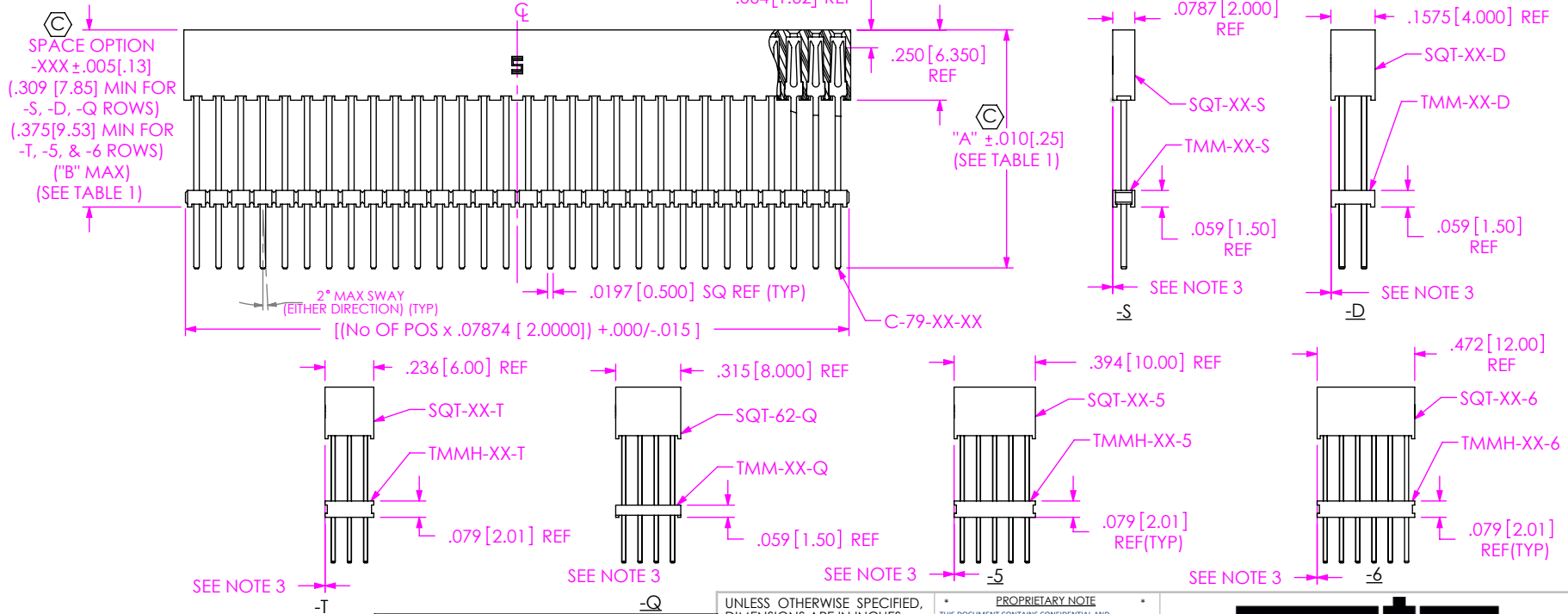

SPACE OPTION
-XXX ± .005 [.13]
(.309 [7.85] MIN FOR -S, -D, -Q ROWS)
(.375 [9.53] MIN FOR -T, -5, & -6 ROWS)
("B" MAX)
(SEE TABLE 1)

2° MAX SWAY (EITHER DIRECTION) (TYP)

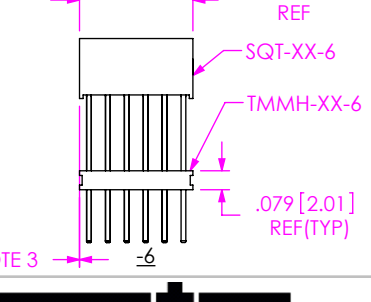
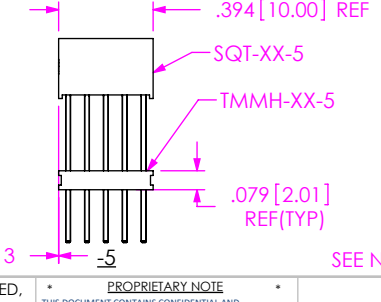
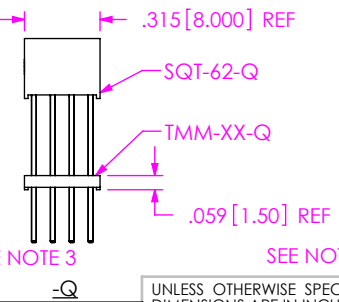
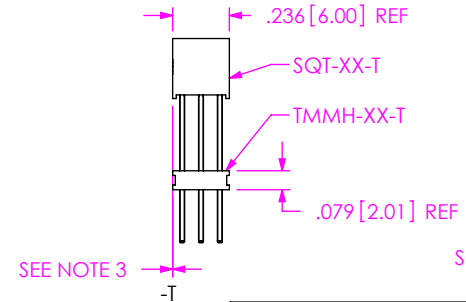

- NOTES:
- ① REPRESENTS A CRITICAL DIMENSION.
 - TOOLING TO BE DESIGNED TO PRODUCE UP TO 61 POSITIONS.
 - TMM / TMMH BODIES ARE NOT TO BE MORE THAN ± .005 FROM PLANE SET BY SQT BODY.
 - XM FOR T, 5 AND 6 ROW OPTIONS CANNOT WITHSTAND PB-FREE REFLOW PROCESSING.
 - MAX CUT FLASH .020 [.51]
 - ORDERS WILL BE PACKAGED ACCORDING TO THE SAMTEC PACKAGING EFFICIENCY STANDARDS (SPES) FOUND ON WWW.SAMTEC.COM

LEAD STYLE	"A"	"B"
-02	.850 [21.59]	.800 [20.32]
-03	.458 [11.63]	.408 [10.36]

UNLESS OTHERWISE SPECIFIED, DIMENSIONS ARE IN INCHES. TOLERANCES ARE: DECIMALS ANGLES
X: ± .1 [2.5]
XX: ± .01 [.3]
XXX: ± .005 [.13]
XXXX: ± .0020 [.051]

PROPRIETARY NOTE
THIS DOCUMENT CONTAINS CONFIDENTIAL AND PROPRIETARY INFORMATION AND ALL DESIGN, MANUFACTURING, REPRODUCTION, USE, PATENT RIGHTS AND SALES RIGHTS ARE EXPRESSLY RESERVED BY SAMTEC, INC. THIS DOCUMENT SHALL NOT BE DISCLOSED, IN WHOLE OR PART, TO ANY UNAUTHORIZED PERSON OR ENTITY NOR REPRODUCED, TRANSFERRED OR INCORPORATED IN ANY OTHER PROJECT IN ANY MANNER WITHOUT THE EXPRESS WRITTEN CONSENT OF SAMTEC, INC.

MATERIAL: DO NOT SCALE DRAWING SHEET SCALE: 2:1
INSULATOR: LCP, UL 94 VO, COLOR: BLACK
CONTACT: PHOS BRONZE



520 PARK EAST BLVD, NEW ALBANY, IN 47150
PHONE: 812-944-6733 FAX: 812-948-5047
e-Mail info@SAMTEC.com code 55322

DESCRIPTION: ELEVATED SQT ASSM.
DWG. NO. ESQT-1XX-XX-XX-X-XXX-XXX-XX
BY: PURVIS 10/20/1995 SHEET 1 OF 3

FIG 2
**** -MW: METAL WASHER**
 (ONE PER POSITION)
 (5 POS MIN, 30 POS MAX)

FLUSH TO $+0.008$ [.20] MAX
 (BELOW TMMH BODY)

3°
 MAX
 SWAY

$.005$ [0.13] MAX
 (MEASURE AT THE TAIL)

SPACE OPTION
 $-XXX +0.008$ [.20]
 $-.005$ [.13]

TMMH-XX-D-XX-XX

**** -MW OPTION, DO NOT DESIGN IN. SAMTEC WILL ONLY SUPPORT EXISTING BUSINESS 2/07/02.**

DETAIL 'A'
 SCALE 6 : 1

DETAIL 'B'
 SCALE 6 : 1

-02 STYLE ONLY

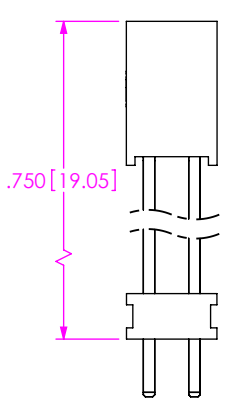

IN PROCESS 1

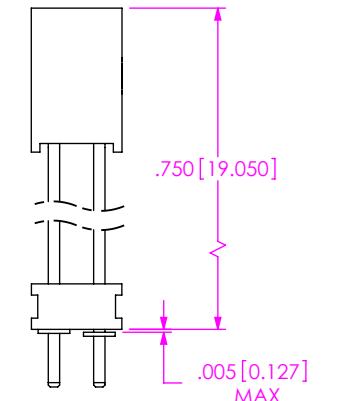

IN PROCESS 2

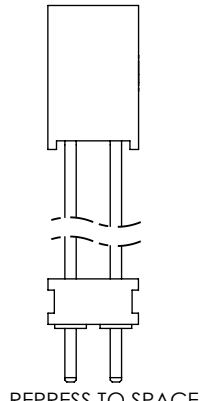

REPRESS TO SPACE OPTION NEEDED
 IN PROCESS 3

TABLE 2

STYLE	ROW	NO. OF POS.	PKG TUBE	TUBE PLUG
-02	-S	15-50 (-MW 5-30 POS)	PT-1-24-01-47	TP-24
-03	-S	15-50 (-MW 5-30 POS)	PT-1-24-01-46	TP-24
-02, -03	-S	02-14	LAYER PACKAGING	
-02	-D	15-50 (-MW 5-30 POS)	PT-1-24-01-34	TP-07
-03	-D	15-50 (-MW 5-30 POS)	PT-1-24-02-46	TP-03
-02, -03	-D	02-14	LAYER PACKAGING	
-02	-T	15-50 (-MW 5-30 POS)	PT-1-24-01-74	TP-07
-03	-T	15-50 (-MW 5-30 POS)	PT-1-24-08-15	TP-07
-02, -03	-T	02-14	LAYER PACKAGING	
-02	-Q	15-50 (-MW 5-30 POS)	PT-1-24-03-51	TP-13
-03	-Q	15-50 (-MW 5-30 POS)	PT-1-24-16-29	TP-07
-02, -03	-Q	02-14	LAYER PACKAGING	
-02	-5	15-50 (-MW 5-30 POS)	PT-1-24-01-56	TP-31
-03	-5	15-50 (-MW 5-30 POS)	PT-1-24-01-08	TP-13
-02, -03	-5	02-14	LAYER PACKAGING	
-02	-6	15-50 (-MW 5-30 POS)	PT-1-24-01-131	TP-26
-03	-6	15-50 (-MW 5-30 POS)	PT-1-24-01-75	TP-13
-02, -03	-6	02-14	LAYER PACKAGING	

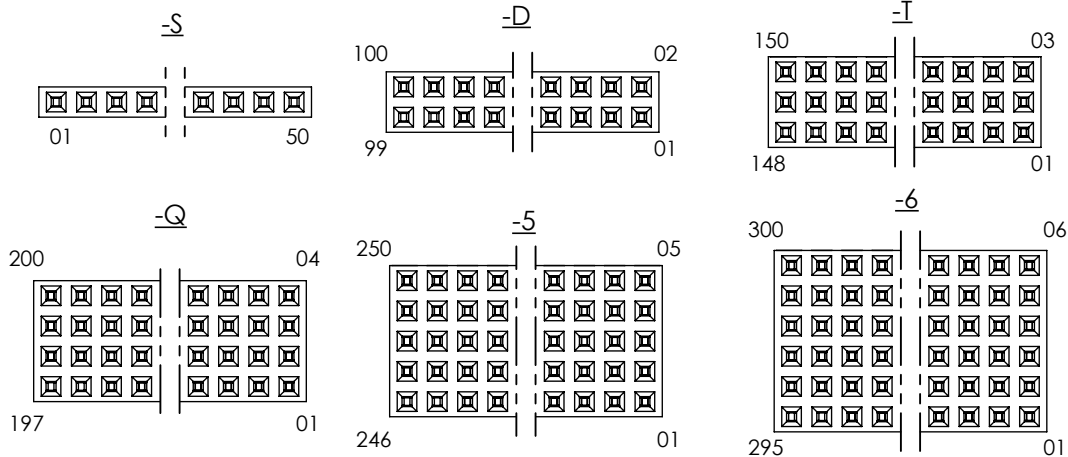

FIG 3
 POLARIZATION OPTION LOCATION
 INSERT PK-07-N INTO SPECIFIED POSITION AND BREAK OFF TAB

NOTE:
 1. MINIMUM CONTACT RETENTION: 0.5 LB PER PIN.

F:\DWG\MISC\MKTG\ESQT-1XX-XX-XX-X-XXX-XXX-XX-MKT.SLDDRW

PROPRIETARY NOTE
 THIS DOCUMENT CONTAINS CONFIDENTIAL AND PROPRIETARY INFORMATION AND ALL DESIGN, MANUFACTURING, REPRODUCTION, USE, PATENT RIGHTS AND SALES RIGHTS ARE EXPRESSLY RESERVED BY SAMTEC, INC. THIS DOCUMENT SHALL NOT BE DISCLOSED, IN WHOLE OR PART, TO ANY UNAUTHORIZED PERSON OR ENTITY NOR REPRODUCED, TRANSFERRED OR INCORPORATED IN ANY OTHER PROJECT IN ANY MANNER WITHOUT THE EXPRESS WRITTEN CONSENT OF SAMTEC, INC.

DO NOT SCALE DRAWING
 SHEET SCALE: 2:1



520 PARK EAST BLVD, NEW ALBANY, IN 47150
 PHONE: 812-944-6733 FAX: 812-948-5047
 e-Mail info@SAMTEC.com code 55322

DESCRIPTION: ELEVATED SQT ASSM.
 DWG. NO. ESQT-1XX-XX-XX-X-XXX-XXX-XX
 BY: PURVIS 10/20/1995 SHEET 2 OF 3

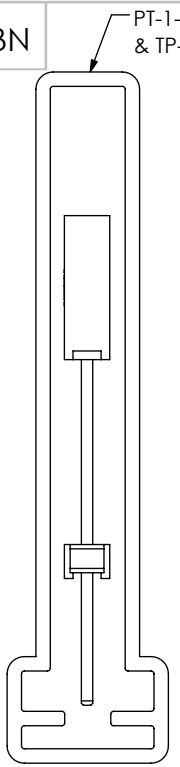

-02-S

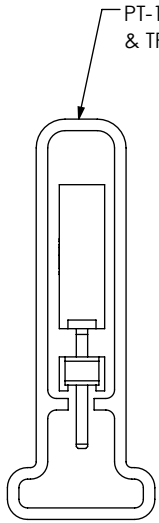

-03-S

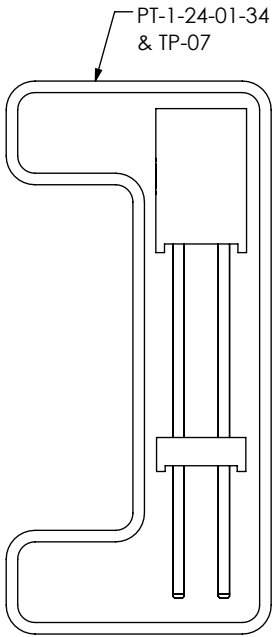

-02-D

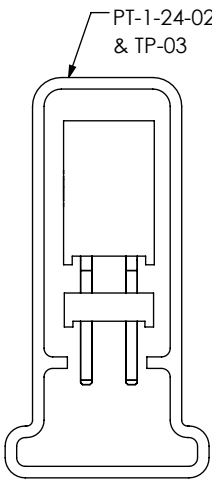

-03-D

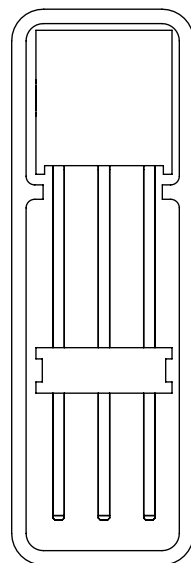

-02-I

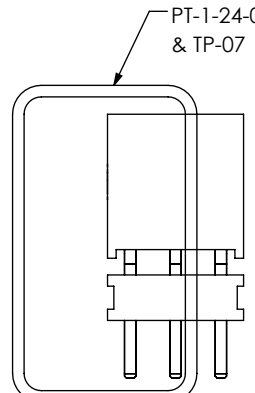

-03-I

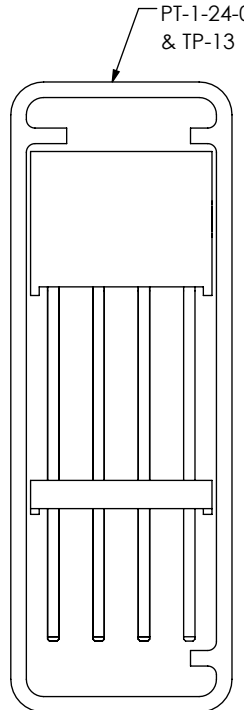

-02-Q

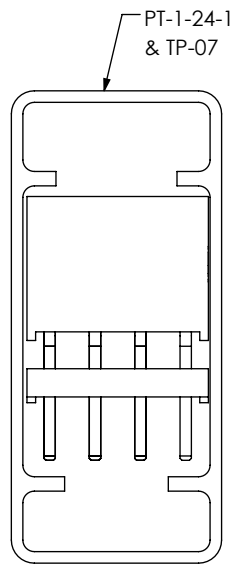

-03-Q

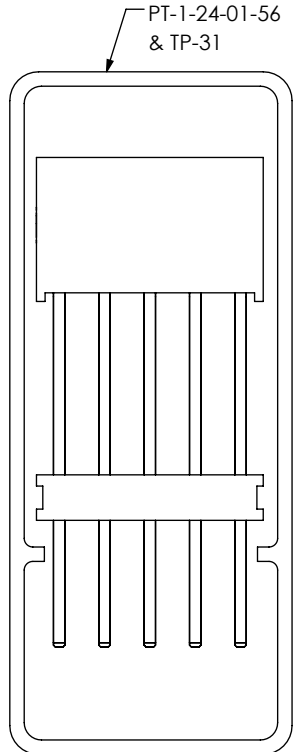

-02-5

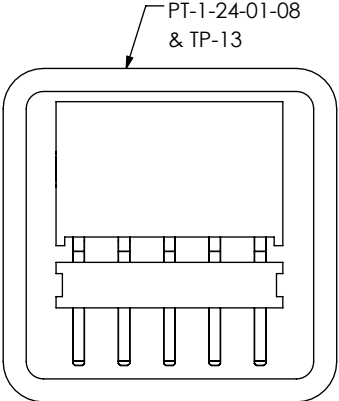

-03-5

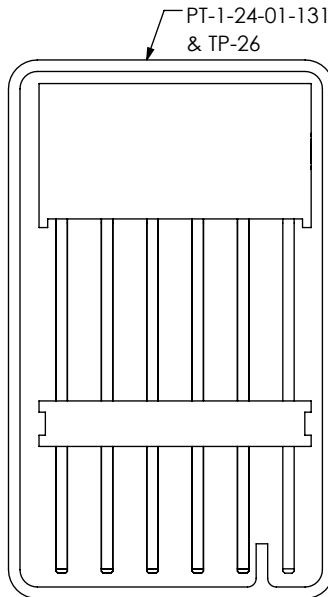

-02-6

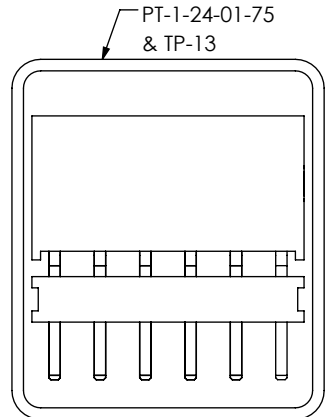

-03-6

PACKAGING VIEWS

PROPRIETARY NOTE
 THIS DOCUMENT CONTAINS CONFIDENTIAL AND PROPRIETARY INFORMATION AND ALL DESIGN, MANUFACTURING, REPRODUCTION, USE, PATENT RIGHTS AND SALES RIGHTS ARE EXPRESSLY RESERVED BY SAMTEC, INC. THIS DOCUMENT SHALL NOT BE DISCLOSED, IN WHOLE OR PART, TO ANY UNAUTHORIZED PERSON OR ENTITY NOR REPRODUCED, TRANSFERRED OR INCORPORATED IN ANY OTHER PROJECT IN ANY MANNER WITHOUT THE EXPRESS WRITTEN CONSENT OF SAMTEC, INC.



520 PARK EAST BLVD, NEW ALBANY, IN 47150
 PHONE: 812-944-6733 FAX: 812-948-5047
 e-Mail: info@SAMTEC.com code 55322

DO NOT SCALE DRAWING

SHEET SCALE: 3:1

DESCRIPTION: ELEVATED SQT ASSM.

DWG. NO. ESQT-1XX-XX-XX-X-XXX-XXX-XX

BY: PURVIS 10/20/1995 SHEET 3 OF 3