

54AC/74AC353 • 54ACT/74ACT353

Dual 4-Input Multiplexer With 3-State Outputs

Description

The 'AC/ACT353 is a dual 4-input multiplexer with 3-state outputs. It can select two bits of data from four sources using common Select inputs. The outputs may be individually switched to a high impedance state with a HIGH on the respective Output Enable (\overline{OE}) inputs, allowing the outputs to interface directly with bus-oriented systems.

- Inverted Version of the 'AC/ACT253
- Multifunction Capability
- Separate Enables for Each Multiplexer
- Outputs Source/Sink 24 mA
- 'ACT353 has TTL-Compatible Inputs

Ordering Code: See Section 6

Logic Symbol

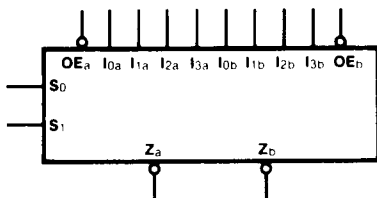

Pin Names

- $I_{0a} - I_{3a}$ Side A Data Inputs
- $I_{0b} - I_{3b}$ Side B Data Inputs
- S_0, S_1 Common Select Inputs
- \overline{OE}_a Side A Output Enable Input
- \overline{OE}_b Side B Output Enable Input
- $\overline{Z}_a, \overline{Z}_b$ 3-State Outputs

Connection Diagrams

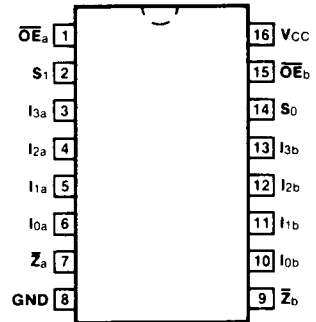

Pin Assignment for DIP, Flatpak and SOIC

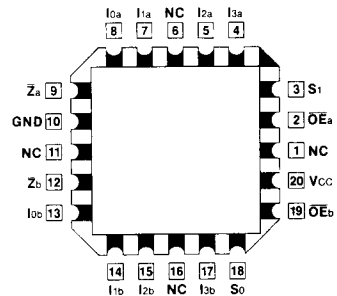

Pin Assignment for LCC and PCC

AC353 • ACT353

Functional Description

The 'AC/ACT353 contains two identical 4-input multiplexers with 3-state outputs. They select two bits from four sources selected by common Select inputs (S₀, S₁). The 4-input multiplexers have individual Output Enable (\overline{OE}_a , \overline{OE}_b) inputs which, when HIGH, force the outputs to a high impedance (High Z) state. The logic equations for the outputs are shown below:

$$Z_a = \overline{OE}_a \cdot (I_{0a} \cdot \overline{S_1} \cdot \overline{S_0} + I_{1a} \cdot \overline{S_1} \cdot S_0 + I_{2a} \cdot S_1 \cdot \overline{S_0} + I_{3a} \cdot S_1 \cdot S_0)$$

$$Z_b = \overline{OE}_b \cdot (I_{0b} \cdot \overline{S_1} \cdot \overline{S_0} + I_{1b} \cdot \overline{S_1} \cdot S_0 + I_{2b} \cdot S_1 \cdot \overline{S_0} + I_{3b} \cdot S_1 \cdot S_0)$$

If the outputs of 3-state devices are tied together, all but one device must be in the high impedance state to avoid high currents that would exceed the maximum ratings. Designers should ensure that Output Enable signals to 3-state devices whose outputs are tied together are designed so that there is no overlap.

Truth Table

Select Inputs		Data Inputs				Output Enable	Outputs
S ₀	S ₁	I ₀	I ₁	I ₂	I ₃	\overline{OE}	Z
X	X	X	X	X	X	H	Z
L	L	L	X	X	X	L	H
L	L	H	X	X	X	L	L
H	L	X	L	X	X	L	H
H	L	X	H	X	X	L	L
L	H	X	X	L	X	L	H
L	H	X	X	H	X	L	L
H	H	X	X	X	L	L	H
H	H	X	X	X	H	L	L

H = HIGH Voltage Level
 L = LOW Voltage Level
 X = Immaterial
 Z = High Impedance

Address inputs S₀ and S₁ are common to both sections.

Logic Diagram

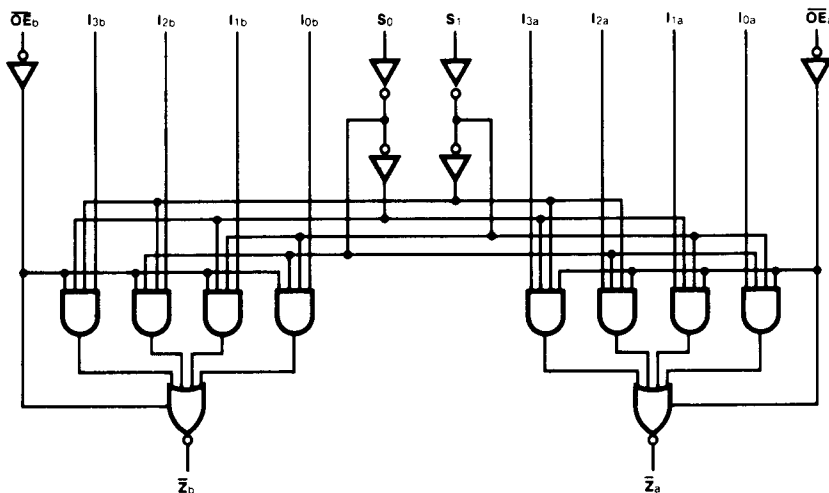

Please note that this diagram is provided only for the understanding of logic operations and should not be used to estimate propagation delays.

DC Characteristics (unless otherwise specified)

Symbol	Parameter	54AC/ACT	74AC/ACT	Units	Conditions
I _{CC}	Maximum Quiescent Supply Current	160	80	μA	V _{IN} = V _{CC} or Ground, V _{CC} = 5.5 V, T _A = Worst Case
I _{CC}	Maximum Quiescent Supply Current	8.0	8.0	μA	V _{IN} = V _{CC} or Ground, V _{CC} = 5.5 V, T _A = 25°C
I _{CC(T)}	Maximum Additional I _{CC} /Input ('ACT353)	1.6	1.5	mA	V _{IN} = V _{CC} - 2.1 V, V _{CC} = 5.5 V, T _A = Worst Case

AC Characteristics

Symbol	Parameter	V _{CC} * (V)	74AC			54AC		74AC		Units	Fig. No.
			T _A = +25°C C _L = 50 pF			T _A = -55°C to +125°C C _L = 50 pF		T _A = -40°C to +85°C C _L = 50 pF			
			Min	Typ	Max	Min	Max	Min	Max		
t _{PLH}	Propagation Delay S _n to Z _n	3.3 5.0	9.0 6.5							ns	3-6
t _{PHL}	Propagation Delay S _n to Z _n	3.3 5.0	9.0 6.5							ns	3-6
t _{PLH}	Propagation Delay I _n to Z _n	3.3 5.0	6.5 5.0							ns	3-5
t _{PHL}	Propagation Delay I _n to Z _n	3.3 5.0	6.5 5.0							ns	3-5
t _{PZH}	Output Enable Time	3.3 5.0	5.5 4.0							ns	3-7
t _{PZL}	Output Enable Time	3.3 5.0	6.0 4.5							ns	3-8
t _{PHZ}	Output Disable Time	3.3 5.0	7.0 5.5							ns	3-7
t _{PLZ}	Output Disable Time	3.3 5.0	5.5 4.0							ns	3-8

*Voltage Range 3.3 is 3.3 V ± 0.3 V
 Voltage Range 5.0 is 5.0 V ± 0.5 V

Military parameters given herein are for general references only. For current military specifications and subgroup testing information please request Fairchild's Table I data sheet from your Fairchild sales engineer or account representative.

AC353 • ACT353

AC Characteristics

Symbol	Parameter	Vcc* (V)	74ACT			54ACT		74ACT		Units	Fig. No.
			TA = +25°C CL = 50 pF			TA = -55°C to +125°C CL = 50 pF		TA = -40°C to +85°C CL = 50 pF			
			Min	Typ	Max	Min	Max	Min	Max		
tPLH	Propagation Delay Sn to Zn	5.0	7.0							ns	3-6
tPHL	Propagation Delay Sn to Zn	5.0	7.0							ns	3-6
tPLH	Propagation Delay In to Zn	5.0	5.5							ns	3-5
tPHL	Propagation Delay In to Zn	5.0	5.5							ns	3-5
tpZH	Output Enable Time	5.0	4.5							ns	3-7
tpZL	Output Enable Time	5.0	5.0							ns	3-8
tPHZ	Output Disable Time	5.0	6.0							ns	3-7
tPLZ	Output Disable Time	5.0	4.5							ns	3-8

*Voltage Range 5.0 is 5.0 V ± 0.5 V

Military parameters given herein are for general references only. For current military specifications and subgroup testing information please request Fairchild's Table I data sheet from your Fairchild sales engineer or account representative.

Capacitance

Symbol	Parameter	54/74AC/ACT	Units	Conditions
		Typ		
CIN	Input Capacitance	4.5	pF	Vcc = 5.5 V
CPD	Power Dissipation Capacitance		pF	Vcc = 5.5 V