

54

DS96172/ $\mu$ A96172/DS96174/ $\mu$ A96174



# DS96172/ $\mu$ A96172/DS96174/ $\mu$ A96174 RS-485/RS-422 Quad Differential Line Drivers

## General Description

The DS96172/ $\mu$ A96172 and DS96174/ $\mu$ A96174 are high speed quad differential line drivers designed to meet EIA Standard RS-485. The devices have TRI-STATE<sup>®</sup> outputs and are optimized for balanced multipoint data bus transmission at rates up to 10 Mbps. The drivers have wide positive and negative common mode range for multipoint applications in noisy environments. Positive and negative current-limiting is provided which protects the drivers from line fault conditions over a +12V to -7.0V common mode range. A thermal shutdown feature is also provided and occurs at junction temperature of approximately 160°C. The DS96172/ $\mu$ A96172 features an active high and active low Enable, common to all four drivers. The DS96174/ $\mu$ A96174 features separate active high Enables for each driver pair. Compatible RS-485 receivers, transceivers, and repeaters are also offered to provide optimum bus performance. The respective device types are DS96173/ $\mu$ A96173, DS96175/ $\mu$ A96175, DS96176/ $\mu$ A96176, DS96177/ $\mu$ A96177 and DS96178/ $\mu$ A96178.

## Features

- Meets EIA Standard RS-485 and RS-422A
- Monotonic differential output switching
- Transmission rate to 10 Mbps
- TRI-STATE outputs
- Designed for multipoint bus transmission
- Common mode output voltage range: -7V to +12V
- Operates from single +5V supply
- Thermal shutdown protection
- DS96172/ $\mu$ A96172/DS96174/ $\mu$ A96174 are lead and function compatible with the SN75172/75174 or the AM26LS31/MC3487 respectively

## Connection Diagrams

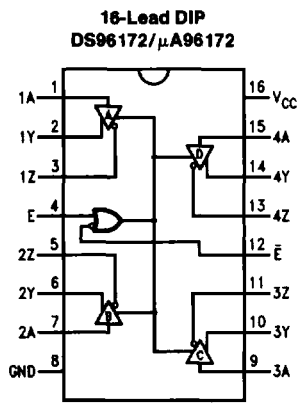

Top View

TL/F/9626-1

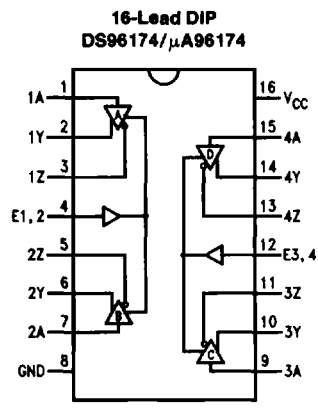

Top View

TL/F/9626-2

Order Number DS96172J,  $\mu$ A96172DC or DS96174J,  $\mu$ A96174DC  
See NS Package Number J16A

Order Number DS96172N,  $\mu$ A96172PC or DS96174N,  $\mu$ A96174PC  
See NS Package Number N16A