

CS-2842A/3843A SERIES

Off-Line Current Mode PWM Control Circuit with Undervoltage Lockout

Description

The CS-284XA, CS-384XA provides all the necessary features to implement off-line fixed frequency current-mode control with a minimum number of external components.

The CS-384XA family incorporates a new precision temperature-controlled oscillator with an internally trimmed discharge current to minimize variations in frequency. A precision duty-cycle clamp eliminates the need for an external oscillator when a 50% duty-cycle is used. Duty-cycles greater than 50% are also possible. On board logic ensures that V_{REF} is stabilized before

the output stage is enabled. Ion implant resistors provide tighter control of undervoltage lockout.

Other features include low start-up current, pulse-by-pulse current limiting, and a high-current totem pole output for driving capacitive loads, such as the gate of power MOSFET. The output is LOW in the off state, consistent with N-channel devices.

The CS-384XA series of current-mode control ICs are available in 8 and 14 lead packages for surface mount (SO) applications as well as 8 lead PDIP packages.

Features

- Optimized for Off-line Control
- Internally Trimmed Temperature Compensated Oscillator
- Maximum Duty-cycle Clamp
- V_{REF} stabilized before Output Stage is Enabled
- Low Start-up Current
- Pulse-by-pulse Current Limiting
- Improved Undervoltage Lockout
- Double Pulse Suppression
- 1% Trimmed Bandgap Reference
- High Current Totem Pole Output

Absolute Maximum Ratings

Supply Voltage ($I_{CC} < 30mA$).....	Self Limiting
Supply Voltage (Low Impedance Source)	30V
Output Current.....	$\pm 1A$
Output Energy (Capacitive Load).....	$5\mu J$
Analog Inputs (V_{FB} , Sense).....	-0.3V to 5.5V
Error Amp Output Sink Current.....	10mA
Lead Temperature Soldering	
Wave Solder (through hole styles only).....	10 sec. max, 260°C peak
Reflow (SMD styles only).....	60 sec. max above 183°C, 230°C peak

Package Options

8 Lead PDIP & SO Narrow

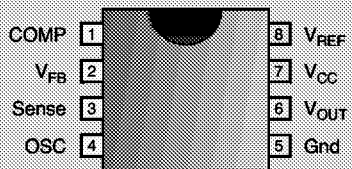

14 Lead SO Narrow

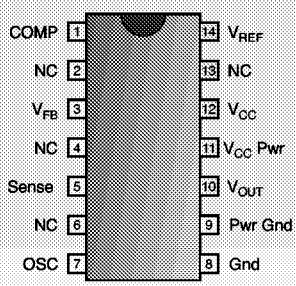

Block Diagram

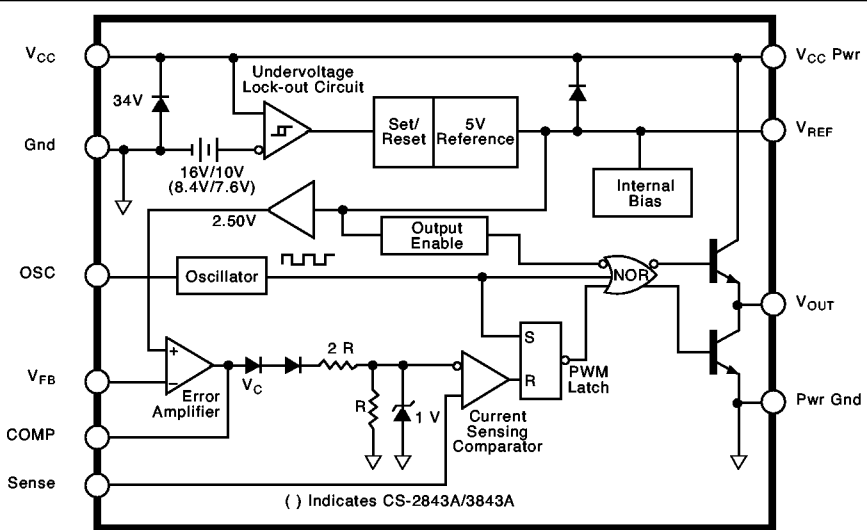

Cherry Semiconductor Corporation
 2000 South County Trail
 East Greenwich, Rhode Island 02818-1530
 Tel: (401)885-3600 Fax (401)885-5786
 email: info@cherry-semi.com

Electrical Characteristics: $-25 \leq T_A \leq 85^\circ\text{C}$ for CS-2842A/2843A, $0 \leq T_A \leq 70^\circ\text{C}$ for CS-3842A/3843A. $V_{CC}=15\text{V}$ (Note 1); $R_T=680\Omega$, $C_T=.022\mu\text{F}$ for triangular mode, $R_T=10\text{k}\Omega$, $C_T=3.3\text{nF}$ for sawtooth mode (see Fig. 3), u unless otherwise stated

PARAMETER	TEST CONDITIONS	CS-2842A/CS-2843A			CS-3842A/CS-3843A			UNITS
		MIN	TYP	MAX	MIN	TYP	MAX	
Reference Section								
Output Voltage	$T_J=25^\circ\text{C}$, $I_{OUT}=1\text{mA}$	4.95	5.00	5.05	4.90	5.00	5.10	V
Line Regulation	$12 \leq V_{IN} \leq 25\text{V}$		6	20		6	20	mV
Load Regulation	$1 \leq I_{OUT} \leq 20\text{mA}$		6	25		6	25	mV
Temperature Stability	(Note 2)		0.2	0.4		0.2	0.4	mV/ $^\circ\text{C}$
Total Output Variation	Line, Load, Temp. (Note 2)	4.90		5.10	4.82		5.18	V
Output Noise Voltage	$10\text{Hz} \leq f \leq 10\text{kHz}$, $T_J=25^\circ\text{C}$ (Note 2)		50			50		μV
Long Term Stability	$T_A=125^\circ\text{C}$, 1kHrs. (Note 2)		5	25		5	25	mV
Output Short Circuit	$T_A=25^\circ\text{C}$	-30	-100	-180	-30	-100	-180	mA
Oscillator Section								
Initial Accuracy	Sawtooth Mode (see Fig. 3), $T_J=25^\circ\text{C}$	47	52	57	47	52	57	kHz
	Triangular Mode (see Fig. 3), $T_J=25^\circ\text{C}$	47	52	57	44	52	60	kHz
Voltage Stability	$12 \leq V_{CC} \leq 25\text{V}$		0.2	1.0		0.2	1.0	%
Temp. Stability	Sawtooth Mode $T_{MIN} \leq T_A \leq T_{MAX}$ (Note 2)		5			5		%
	Triangular Mode $T_{MIN} \leq T_A \leq T_{MAX}$ (Note 2)		8			8		%
Amplitude	OSC peak to peak		1.7			1.7		V
Discharge Current	$T_J=25^\circ\text{C}$	7.5	8.3	9.3	7.5	8.3	9.3	mA
	$T_{MIN} \leq T_A \leq T_{MAX}$	7.2		9.5	7.2		9.5	mA
Error Amp Section								
Input Voltage	$V_{COMP}=2.5\text{V}$	2.45	2.50	2.55	2.42	2.50	2.58	V
Input Bias Current	$V_{FB}=0$		-0.3	-1.0		-0.3	-2.0	μA
A_{VOL}	$2 \leq V_{OUT} \leq 4\text{V}$	65	90		65	90		dB
Unity Gain Bandwidth	(Note 2)	0.7	1.0		0.7	1.0		MHz
PSRR	$12 \leq V_{CC} \leq 25\text{V}$	60	70		60	70		dB
Output Sink Current	$V_{FB}=2.7\text{V}$, $V_{COMP}=1.1\text{V}$	2	6		2	6		mA
Output Source Current	$V_{FB}=2.3\text{V}$, $V_{COMP}=5\text{V}$	-0.5	-0.8		-0.5	-0.8		mA
V_{OUT} High	$V_{FB}=2.3\text{V}$, $R_L=15\text{k}\Omega$ to ground	5	6		5	6		V
V_{OUT} Low	$V_{FB}=2.7\text{V}$, $R_L=15\text{k}\Omega$ to V_{REF}		0.7	1.1		0.7	1.1	V
Current Sense Section								
Gain	(Notes 3 & 4)	2.85	3.00	3.15	2.85	3.00	3.15	V/V
Maximum Input Signal	$V_{COMP}=5\text{V}$ (Note 3)	0.9	1.0	1.1	0.9	1.0	1.1	V
PSRR	$12 \leq V_{CC} \leq 25\text{V}$ (Note 3)		70			70		dB
Input Bias Current	$V_{Sense}=0$		-2	-10		-2	-10	μA
Delay to Output	$T_J=25^\circ\text{C}$ (Note 2)		150	300		150	300	ns
Output Section								
Output Low Level	$I_{SINK}=20\text{mA}$		0.1	0.4		0.1	0.4	V
	$I_{SINK}=200\text{mA}$		1.5	2.2		1.5	2.2	V
Output High Level	$I_{SOURCE}=20\text{mA}$	13.0	13.5		13.0	13.5		V
	$I_{SOURCE}=200\text{mA}$	12.0	13.5		12.0	13.5		V

Electrical Characteristics: continued

PARAMETER	TEST CONDITIONS	CS-2842A/CS-2843A			CS-3842A/CS-3843A			UNITS
		MIN	TYP	MAX	MIN	TYP	MAX	
■ Output Section: continued								
Rise Time	T _J =25°C, C _L =1nF (Note 2)		50	150		50	150	ns
Fall Time	T _J =25°C, C _L =1nF (Note 2)		50	150		50	150	ns
Output Leakage	UVLO Active, V _{OUT} =0		-0.01	-10.00		-0.01	-10.00	μA

■ Total Standby Current

Start-Up Current			0.5	1.0		0.5	1.0	mA
Operating Supply Current	V _{FB} =V _{Sense} =0V R _T =10kΩ, C _T =3.3nF		11	17		11	17	mA
V _{CC} Zener Voltage	I _{CC} =25mA		34			34		V

PARAMETER	TEST CONDITIONS	CS-2842A			CS-3842A			CS-2843A/CS-3843A			UNITS
		MIN	TYP	MAX	MIN	TYP	MAX	MIN	TYP	MAX	

■ Under-Voltage Lockout Section

Start Threshold		15	16	17	14.5	16.0	17.5	7.8	8.4	9.0	V
Min. Operating Voltage	After Turn On	9	10	11	8.5	10.0	11.5	7.0	7.6	8.2	V

Notes: 1. Adjust V_{CC} above the start threshold before setting at 15V.

2. These parameters, although guaranteed, are not 100% tested in production.

3. Parameter measured at trip point of latch with V_{FB}=0.

4. Gain defined as:

$$A = \frac{\Delta V_{COMP}}{\Delta V_{Sense}} ; 0 \leq V_{Sense} \leq 0.8V.$$

Package Pin Description

PACKAGE PIN #		PIN SYMBOL	FUNCTION
8L PDIP/SO	14L SO Narrow		
1	1	COMP	Error amp output, used to compensate error amplifier
2	3	V _{FB}	Error amp inverting input
3	5	Sense	Noninverting input to Current Sense Comparator
4	7	OSC	Oscillator timing network with Capacitor to Ground, resistor to V _{REF}
5	8	Gnd	Ground
	9	Pwr Gnd	Output driver Ground
6	10	V _{OUT}	Output drive pin
	11	V _{CC} Pwr	Output driver positive supply
7	12	V _{CC}	Positive power supply
8	14	V _{REF}	Output of 5V internal reference
	2,4,6,13	NC	No Connection

Typical Performance Characteristics

Oscillator Frequency vs C_T

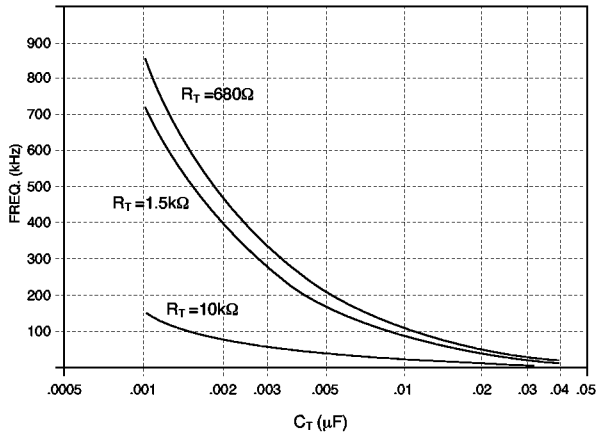

Oscillator Duty Cycle vs R_T

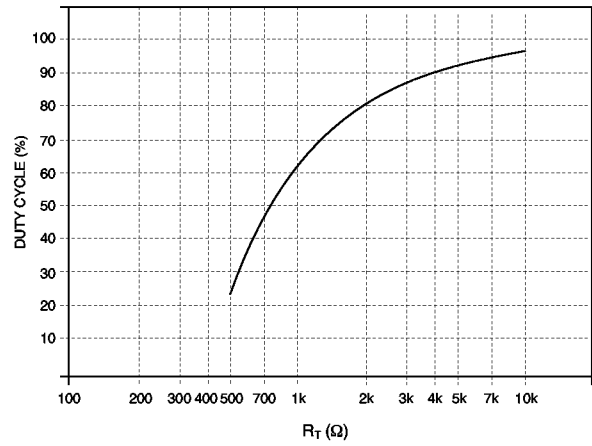

Test Circuit

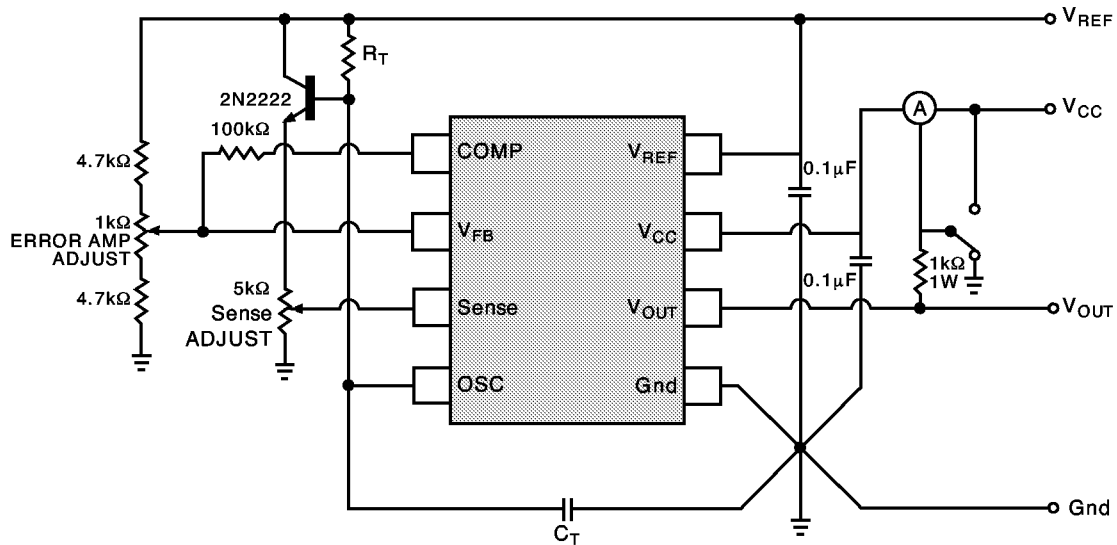

Circuit Description

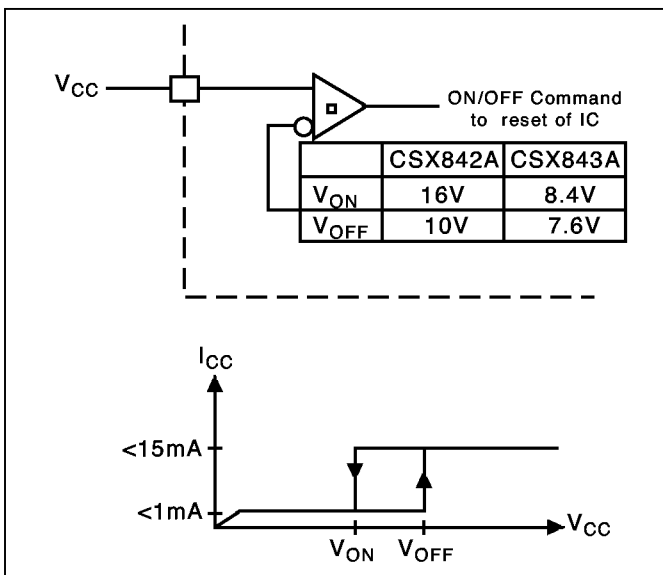

Figure 1: Typical Undervoltage Characteristics

Undervoltage Lockout

During Undervoltage Lockout (Figure 1), the output driver is biased to a high impedance state. The output should be shunted to ground with a resistor to prevent output leakage current from activating the power switch.

PWM Waveform

To generate the PWM waveform, the control voltage from the error amplifier is compared to a current sense signal which represents the peak output inductor current (Figure 2). An increase in V_{CC} causes the inductor current slope to increase, thus reducing the duty cycle. This is an inherent feed-forward characteristic of current mode control, since the control voltage does not have to change during changes of input supply voltage.

When the power supply sees a sudden large output current increase, the control voltage will increase allowing the duty cycle to momentarily increase. Since the duty cycle tends to exceed the maximum allowed to prevent trans-

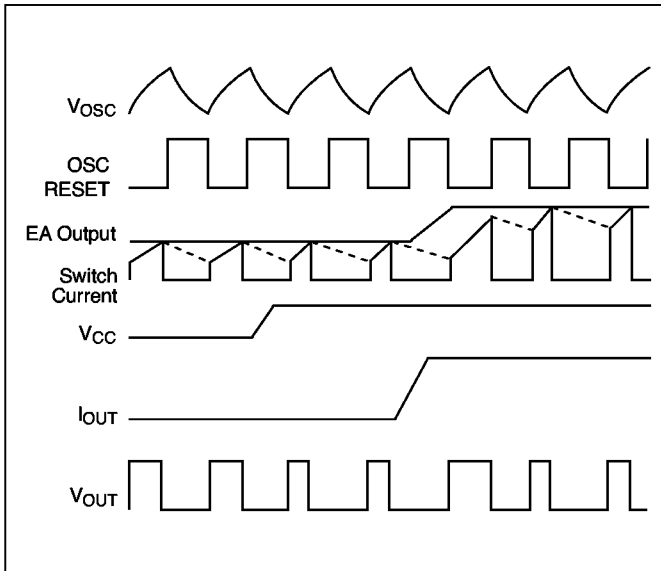

Figure 2: Timing Diagram for key CS-2841B parameters

former saturation in some power supplies, the internal oscillator waveform provides the maximum duty cycle clamp as programmed by the selection of oscillator components.

Setting the Oscillator

Oscillator timing capacitor, C_T , is charged by V_{REF} through R_T and discharged by an internal current source. During the discharge time, the internal clock signal blanks out the output to the Low state, thus providing a user selected maximum duty cycle clamp. Charge and discharge times are determined by the formula:

$$t_c = R_T C_T \ln \left(\frac{V_{REF} - V_{lower}}{V_{REF} - V_{upper}} \right)$$

$$t_d = R_T C_T \ln \left(\frac{V_{REF} - I_d R_T - V_{lower}}{V_{REF} - I_d R_T - V_{upper}} \right)$$

Substituting in typical values for the parameters in the above formulas:

$$V_{REF} = 5.0V, V_{upper} = 2.7V, V_{lower} = 1.0V, I_d = 8.3A$$

$$t_c \approx 0.5534 R_T C_T$$

$$t_d = R_T C_T \ln \left(\frac{2.3 - 0.0083 R_T}{4.0 - 0.0083 R_T} \right)$$

The frequency and maximum duty cycle can be determined using the Typical Performance Characteristic graphs.

Grounding

High peak currents associated with capacitive loads necessitate careful grounding techniques. Timing and bypass capacitors should be connected close to Gnd pin in a single point ground.

The transistor and 5kΩ potentiometer, shown in the test circuit, are used to sample the oscillator waveform and apply an adjustable ramp to Sense.

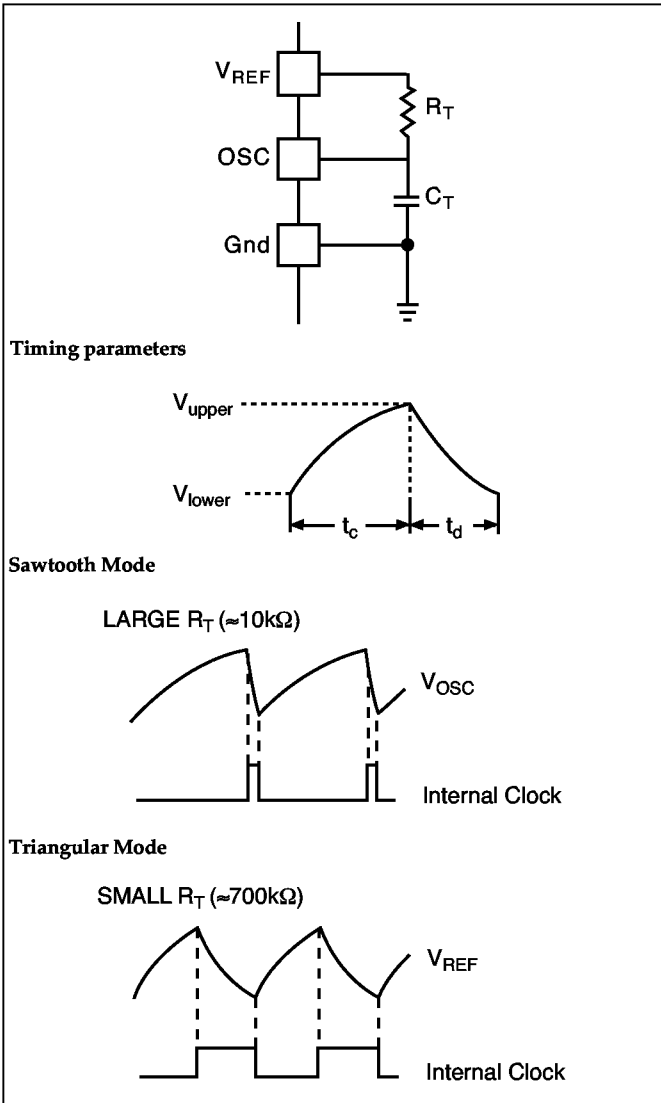

Figure 3: Oscillator Timing Network and parameters

Package Specification

PACKAGE DIMENSIONS IN mm (INCHES)

Lead Count	D			
	Metric		English	
	Max	Min	Max	Min
8 Lead PDIP	9.40	9.14	.370	.360
8 Lead SO Narrow	5.00	4.80	.197	.188
14 Lead SO Narrow	8.74	8.53	.344	.336

PACKAGE THERMAL DATA

Thermal Data		8 L PDIP	8 L SO Narrow	14 L SO Narrow	
$R_{\theta JC}$	typ	52	45	30	$^{\circ}C/W$
$R_{\theta JA}$	typ	100	165	125	$^{\circ}C/W$

8 & 14L SO Narrow

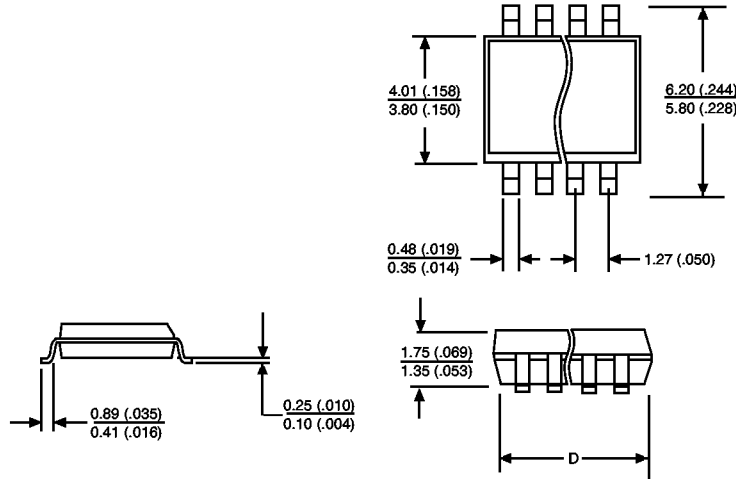

8 L PDIP

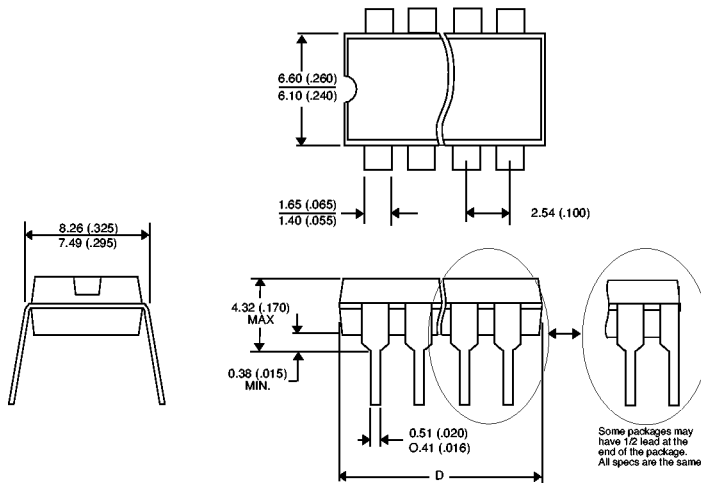

Ordering Information

Part Number	0°C to 70°C	-25°C to 85°C	Description
CS-2842AN8		•	8L PDIP
CS-2843AN8		•	8L PDIP
CS-3842AN8	•		8L PDIP
CS-3842AD8	•		8L SO Narrow
CS-3842AD14	•		14L SO Narrow
CS-2843AD14		•	14L SO Narrow
CS-3843AN8	•		8L PDIP
CS-3843AD8	•		8L SO Narrow
CS-3843AD14	•		14L SO Narrow

Cherry Semiconductor Corporation reserves the right to make changes to the specifications without notice. Please contact Cherry Semiconductor Corporation for the latest available information.