



Dual High-Speed FET Driver

FEATURES

- 1.5 Amp Source/Sink Drive
- Pin Compatible with 0026 Products
- 40 ns Rise and Fall into 1000 pF
- Low Quiescent Current
- 5V to 40V Operation
- Thermal Protection

DESCRIPTION

The UC3709 family of power drivers is an effective low-cost solution to the problem of providing fast turn-on and off for the capacitive gates of power MOSFETs. Made with a high-speed Schottky process, these devices will provide up to 1.5 amps of either source or sink current from a totem-pole output stage configured for minimal cross-conduction current spike.

The UC3709 is pin compatible with the MMH0026 or DS0026, and while the delay times are longer, the supply current is much less than these older devices.

With inverting logic, these units feature complete TTL compatibility at the inputs with an output stage that can swing over 30V. This design also includes thermal shutdown protection.

ABSOLUTE MAXIMUM RATINGS

	N-Pkg	J-Pkg
Supply Voltage, V_{CC}	40V	40V
Output Current (Source or Sink)		
Steady-State	±500	±500 mA
Peak Transient	±1.5A	±1.0A
Capacitive Discharge Energy	20 μ J	15 μ J
Digital Inputs (See Note)	5.5V	5.5V
Power Dissipation at $T_A = 25^\circ\text{C}$	1W	1W
Power Dissipation at $T_C = 25^\circ\text{C}$	3W	2W
Operating Temperature Range	-55°C to +125°C	-55°C to +125°C
Storage Temperature Range	-65°C to +150°C	-65°C to +150°C
Lead Temperature (Soldering, 10 Seconds)	300°C	300°C

Note: All currents are positive into, negative out of the specified terminals. Digital drive can exceed 5.5V if input current is limited to 10mA. Consult Packaging section of Databook for thermal limitations and considerations of package.

SIMPLIFIED SCHEMATIC (Only One Driver Shown)

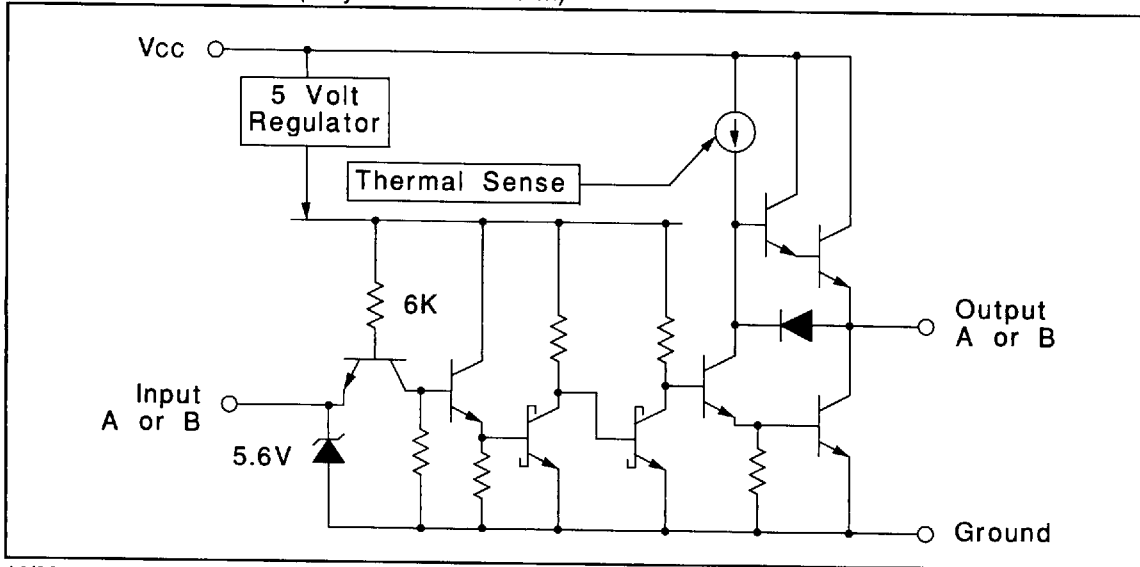

CONNECTION DIAGRAMS

8 PIN DIL (TOP VIEW)
N or J Package

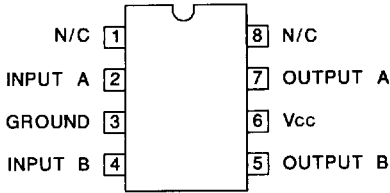

SOIC-16 (TOP VIEW)
DW Package

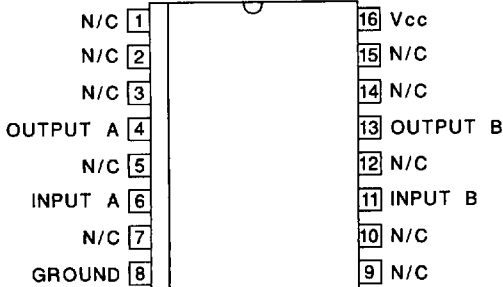

PLCC-20, LCC-20 (TOP VIEW)
Q, L Packages

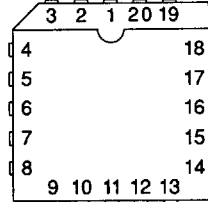

PACKAGE PIN FUNCTION	
FUNCTION	PIN
N/C	1
N/C	2
INPUT A	3
N/C	4
N/C	5
GROUND	6
N/C	7
N/C	8
INPUT B	9
N/C	10
N/C	11
OUTPUT B	12
N/C	13
N/C	14
N/C	15
Vcc	16
N/C	17
N/C	18
N/C	19
OUTPUT A	20

ELECTRICAL CHARACTERISTICS: Unless otherwise stated, these specifications apply for TA = -55°C to +125°C for the UC1709, -40°C to +85°C for the UC2709, and 0°C to +70°C for the UC3709; Vcc = 20V, TA = TJ.

PARAMETERS	TEST CONDITIONS	MIN	TYP	MAX	UNITS
Supply Current	Both Outputs High		10	12	mA
	Both Outputs Low		7	10	mA
Logic 0 Input Voltage				0.8	V
Logic 1 Input Voltage		2.2			V
Input Current	Vi = 0		-0.6	-1.0	mA
Input Leakage	Vi = 5V		0.05	0.1	mA
Output High Sat., Vcc-Vo	Io = -50mA		1.5	2.0	V
	Io = -500mA		2.0	2.5	V
Output Low Sat., Vo	Io = 50mA		0.1	0.4	V
	Io = 500mA		2.0	2.5	V
Thermal Shutdown			155		°C

TYPICAL SWITCHING CHARACTERISTICS: Vcc = 20V, TA = 25°C. Delays measured to 10% output change.

PARAMETERS	TEST CONDITIONS	OUTPUT CL =		UNIT
		0 nF	2.2 nF	
Rise Time Delay		80	80	ns
10% to 90% Rise		20	40	ns
Fall Time Delay		60	80	ns
90% to 10% Fall		20	40	ns
Vcc Cross-Conduction	Output Rise	25		ns
Current Spike Duration	Output Fall	0		ns

Note: Refer to UC1705 specifications for further information

APPLICATIONS

Power Bipolar Drive Circuit

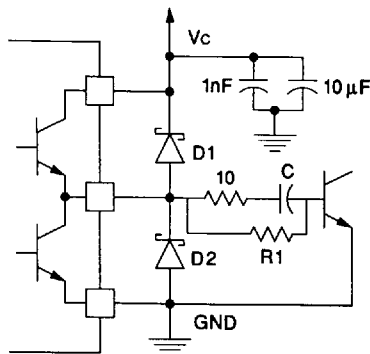

D1, D2: UC3611 Schottky Diodes

Transformer Coupled Push-Pull MOSFET Drive Circuit

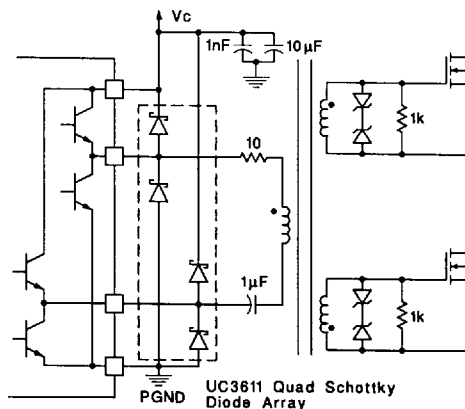

D1, D2: UC3611 Schottky Diodes

Power MOSFET Drive Circuit

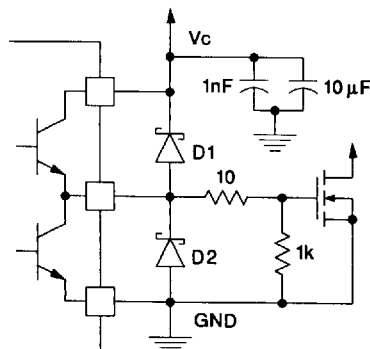

D1, D2: UC3611 Schottky Diodes

Power MOSFET Drive Circuit Using Negative Bias Voltage and Level Shifting To Ground Referenced PWMS

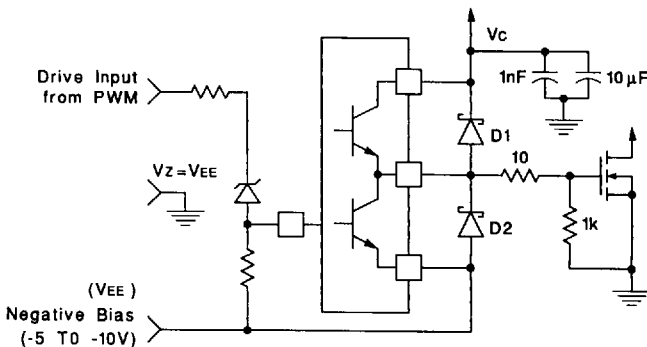

D1, D2: UC3611 Schottky Diodes

Charge Pump Circuits

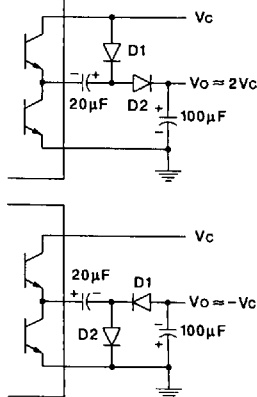

Transformer Coupled MOSFET Drive Circuit

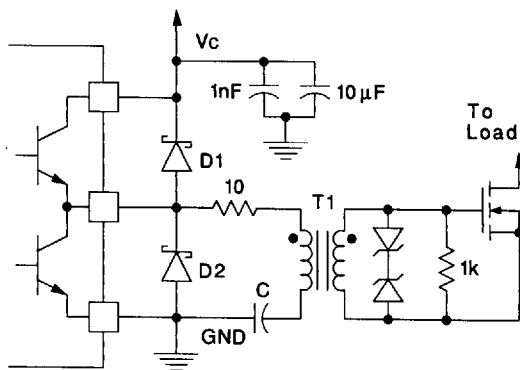

D1, D2: UC3611 Schottky Diodes