

### Characters

- Chip LED (1.6x0.8x0.6)
- Super compact type



### Package Outline Dimensions

(Unit:mm Tolerance:+/-0.1)

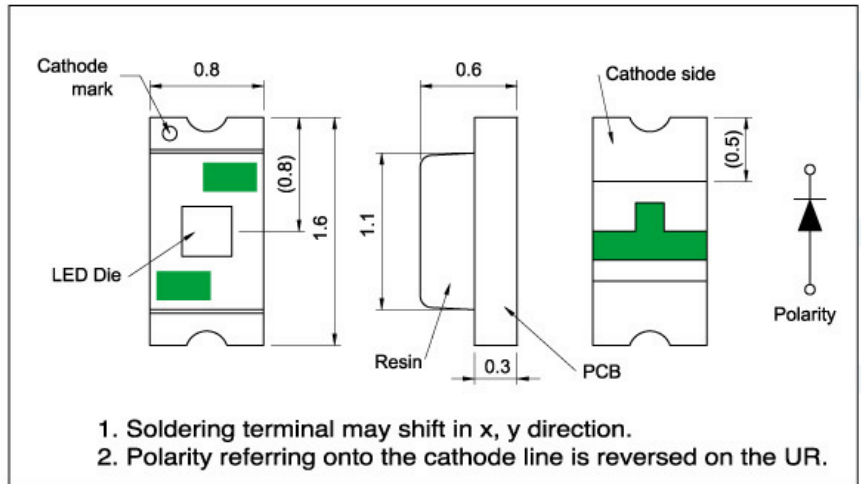

### Directive Characteristics

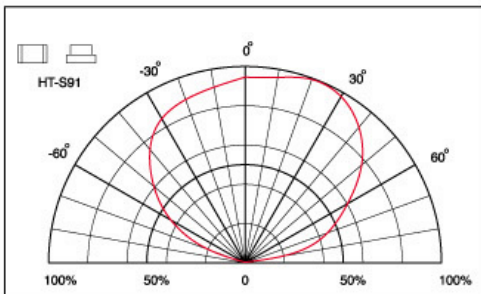
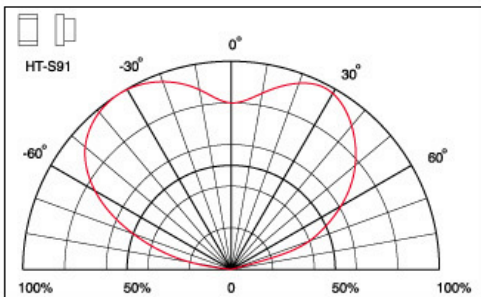

### Recommended Soldering Pattern

Unit: mm

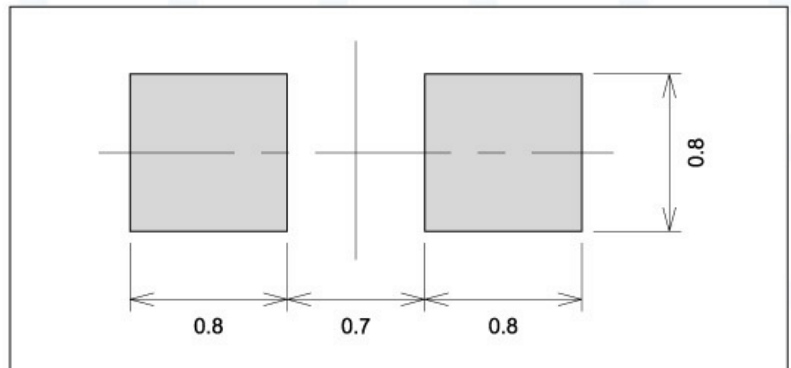

### Absolute Maximum Ratings

(Ta=25 °C)

Item	Symbol	Value					Unit
		GaP	GaAsP	AlGaAs	AlInGaP	InGaN	
Power Dissipation	P <sub>D</sub>	65	65	66	72	78	mW
DC Forward Current	I <sub>F</sub>	25	25	30	30	20	mA
Pulsed Forward Current	I <sub>FP</sub> *	100	100	100	100	80	mA
Reverse Voltage (I <sub>R</sub> =100uA)	V <sub>R</sub>	5					V
Operating Temperature	T <sub>OP</sub>	-30 to 80					°C
Storage Temperature	T <sub>ST</sub>	-40 to 85					°C

\*Condition for I<sub>FP</sub> is pulse of 1/10 duty and 0.1msec width

## Electrical-Optical Characteristics

(Ta=25 °C)

Code for parts	Lighting Color	Material	Forward Voltage (V)		Wavelength (nm) typ			Luminous Intensity (mcd)*		I <sub>F</sub> (mA)
			typ	max	λ <sub>D</sub>	λ <sub>P</sub>	Δλ	min	typ	
HT-S91YG	Yellow Green	GaP	2.2	2.6	573	568	30	9	20	20
HT-S91Y	Yellow	GaAsP	2.1	2.6	590	589	35	3.6	8	20
HT-S91D	Amber	GaAsP	2.1	2.6	608	610	35	3.6	9	20
HT-S91SD	Super Bright Orange	GaAsP	2.1	2.6	629	642	35	5.6	11	20
HT-S91UR	Super Bright Red	AlGaAs	1.8	2.2	643	660	20	9	16	20

Code for parts	Lighting Color	Material	Forward Voltage (V)		Wavelength (nm) typ			Luminous Intensity (mcd)*		I <sub>F</sub> (mA)
			typ	max	λ <sub>D</sub>	λ <sub>P</sub>	Δλ	min	typ	
HT-S91UYG	Ultra Bright Yellow Green	AllnGaP	2.0	2.4	573	574	20	35	60	20
HT-S91UY	Ultra Bright Yellow	AllnGaP	1.9	2.4	591	593	15	35	140	20
HT-S91UD	Ultra Bright Amber	AllnGaP	1.9	2.4	605	609	17	25	110	20
HT-S91USD	Ultra Bright Orange	AllnGaP	1.9	2.4	622	636	17	56	120	20

Code for parts	Lighting Color	Material	I <sub>F</sub> = 20mA						I <sub>F</sub> = 5mA							
			Forward Voltage (V)		Wavelength (nm) typ			Luminous Intensity (mcd)*		Forward Voltage (V)		Wavelength (nm) typ			Luminous Intensity (mcd)*	
			typ	max	λ <sub>D</sub>	λ <sub>P</sub>	Δλ	min	typ	typ	max	λ <sub>D</sub>	λ <sub>P</sub>	Δλ	min	typ
HT-S91NB	Blue	InGaN	3.3	3.9	470	468	40	25	40	2.8	3.15	472	470	40	9	25
HT-S91NG	Green	InGaN	3.3	3.9	527	520	40	60	140	2.8	3.15	529	522	40	15	45
HT-S91TW	White	InGaN	3.3	3.9	X=0.29 Y=0.31	-	-	140	285	2.8	3.15	X=0.29 Y=0.32	-	-	25	60

\*Per NIST standards

