

CD54/74HC126 CD54/74HCT126

High-Speed CMOS Logic

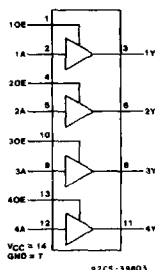

FUNCTIONAL DIAGRAM

Quad Buffer, 3-State

Type Features:

- Separate output enable inputs
- 3-state outputs

The RCA CD54/74HC126 and CD54/74HCT126 contain four independent 3-state buffers, each having its own output enable input, which when "low" puts the output in the high-impedance state.

The CD54HC/HCT126 are supplied in 14-lead hermetic dual-in-line ceramic packages (F suffix). The CD74HC/HCT126 are supplied in 14-lead dual-in-line plastic packages (E suffix) and in 14-lead dual-in-line surface mount plastic packages (M suffix). Both types are also available in chip form (H suffix).

Family Features:

- Fanout (Over Temperature Range):
Standard Outputs - 10 LSTTL Loads
Bus Driver Outputs - 15 LSTTL Loads
- Wide Operating Temperature Range:
CD74HC/HCT/HCU: -40 to +85°C
- Balanced Propagation Delay and Transition Times
- Significant Power Reduction Compared to LSTTL Logic ICs
- Alternate Source is Philips/Signetics
- CD54HC/CD74HC Types:
2 to 6 V Operation
High Noise Immunity:
 $N_{IL} = 30\%$, $N_{IH} = 30\%$ of V_{CC} ; @ $V_{CC} = 5 V$
- CD54HCT/CD74HCT Types:
4.5 to 5.5 V Operation
Direct LSTTL Input Logic Compatibility
 $V_{IL} = 0.8 V$ Max., $V_{IH} = 2 V$ Min.
CMOS Input Compatibility $I_{iL} \leq 1 \mu A$ @ V_{OL} , V_{OH}

TRUTH TABLE

Inputs		Outputs
nA	nOE	nY
H	H	H
L	H	L
X	L	Z

H = High Level
L = Low Level
X = Don't Care
Z = High Impedance (Off-State)

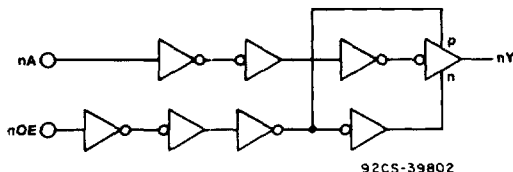

Fig. 1 - Logic Diagram

CD54/74HC126 CD54/74HCT126

MAXIMUM RATINGS, Absolute-Maximum Values:

DC SUPPLY-VOLTAGE, (V_{cc}):

(Voltages referenced to ground) -0.5 to +7 V

DC INPUT DIODE CURRENT, I_{IK} (FOR V_I < -0.5 V OR V_I > V_{cc} + 0.5 V) ±20mA

DC OUTPUT DIODE CURRENT, I_{OK} (FOR V_O < -0.5 V OR V_O > V_{cc} + 0.5 V) ±20mA

DC DRAIN CURRENT, PER OUTPUT (I_O) (FOR -0.5 V < V_O < V_{cc} + 0.5 V) ±35mA

DC V_{cc} OR GROUND CURRENT (I_{cc}) ±70mA

POWER DISSIPATION PER PACKAGE (P_D):

For T_A = -40 to +60°C (PACKAGE TYPE E) 500 mW

For T_A = +60 to +85°C (PACKAGE TYPE E) Derate Linearly at 8 mW/°C to 300 mW

For T_A = -55 to +100°C (PACKAGE TYPE F, H) 500 mW

For T_A = +100 to +125°C (PACKAGE TYPE F, H) Derate Linearly at 8 mW/°C to 300 mW

For T_A = -40 to +70°C (PACKAGE TYPE M) 400 mW

For T_A = +70 to +125°C (PACKAGE TYPE M) Derate Linearly at 6 mW/°C to 70 mW

OPERATING-TEMPERATURE RANGE (T_A):

PACKAGE TYPE F, H -55 to +125°C

PACKAGE TYPE E, M -40 to +85°C

STORAGE TEMPERATURE (T_{stg}) -65 to +150°C

LEAD TEMPERATURE (DURING SOLDERING):

At distance 1/16 ± 1/32 in. (1.59 ± 0.79 mm) from case for 10 s max. +265°C

Unit inserted into a PC Board (min. thickness 1/16 in., 1.59 mm)

with solder contacting lead tips only +300°C

RECOMMENDED OPERATING CONDITIONS:

For maximum reliability, nominal operating conditions should be selected so that operation is always within the following ranges:

CHARACTERISTIC	LIMITS		UNITS
	MIN.	MAX.	
Supply-Voltage Range (For T _A = Full Package-Temperature Range) V _{cc} .* CD54/74HC Types CD54/74HCT Types	2 4.5	6 5.5	V
DC Input or Output Voltage V _I , V _O	0	V _{cc}	V
Operating Temperature T _A : CD74 Types CD54 Types	-40 -55	+85 +125	°C
Input Rise and Fall Times t _r , t _f at 2 V at 4.5 V at 6 V	0 0 0	1000 500 400	ns

*Unless otherwise specified, all voltages are referenced to Ground.

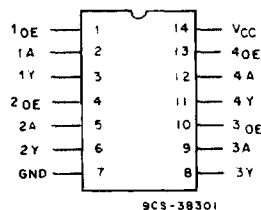

TERMINAL ASSIGNMENT

CD54/74HC126 CD54/74HCT126

STATIC ELECTRICAL CHARACTERISTICS

CHARACTERISTIC	CD74HC126/CD54HC126										CD74HCT126/CD54HCT126										UNITS
	TEST CONDITIONS			74HC/54HC TYPES			74HC TYPE		54HC TYPE		TEST CONDITIONS		74HCT/54HCT TYPES			74HCT TYPE		54HCT TYPE			
	V _I V	I _O mA	V _{CC} V	+25°C			-40/ +85°C		-55/ +125°C		V _I V	V _{CC} V	+25°C			-40/ +85°C		-55/ +125°C			
				Min	Typ	Max	Min	Max	Min	Max			Min	Typ	Max	Min	Max	Min	Max		
High-Level Input Voltage V _{IH}			2	1.5	—	—	1.5	—	1.5	—	—	4.5									V
			4.5	3.15	—	—	3.15	—	3.15	—	—	to	2	—	—	2	—	2	—		
			6	4.2	—	—	4.2	—	4.2	—	—	5.5									
Low-Level Input Voltage V _{IL}			2	—	—	0.5	—	0.5	—	0.5	—	4.5									V
			4.5	—	—	1.35	—	1.35	—	1.35	—	to	—	—	0.8	—	0.8	—	0.8	—	
			6	—	—	1.8	—	1.8	—	1.8	—	5.5									
High-Level Output Voltage V _{OH}	V _{IL}		2	1.9	—	—	1.9	—	1.9	—	V _{IL}										V
or		-0.02	4.5	4.4	—	—	4.4	—	4.4	—	or	4.5	4.4	—	—	4.4	—	4.4	—		
CMOS Loads	V _{IH}		6	5.9	—	—	5.9	—	5.9	—	V _{IH}										
TTL Loads (Bus Driver)	V _{IL}										V _{IL}										V
or			-6	4.5	3.98	—	—	3.84	—	3.7	—	or	4.5	3.98	—	—	3.84	—	3.7	—	
V _{IH}			-7.8	6	5.48	—	—	5.34	—	5.2	—	V _{IH}									
Low-Level Output Voltage V _{OL}	V _{IL}		2	—	—	0.1	—	0.1	—	0.1	V _{IL}										V
or		0.02	4.5	—	—	0.1	—	0.1	—	0.1	or	4.5	—	—	0.1	—	0.1	—	0.1	—	
CMOS Loads	V _{IH}		6	—	—	0.1	—	0.1	—	0.1	V _{IH}										
TTL Loads (Bus Driver)	V _{IL}										V _{IL}										V
or			6	4.5	—	—	0.26	—	0.33	—	0.4	or	4.5	—	—	0.26	—	0.33	—	0.4	
V _{IH}			7.8	6	—	—	0.26	—	0.33	—	0.4	V _{IH}									
Input Leakage Current I _I	V _{CC}		6	—	—	±0.1	—	±1	—	±1	Any Voltage Between V _{CC} and Gnd	5.5	—	—	±0.1	—	±1	—	±1	—	μA
or	Gnd																				
Quiescent Device Current I _{CC}	V _{CC}		0	6	—	—	8	—	80	—	160	V _{CC}	5.5	—	—	8	—	80	—	160	μA
or	Gnd											or									
Additional Quiescent Device Current per input pin: 1 unit load ΔI _{CC} *												V _{CC} -2.1	4.5 to 5.5	—	100	360	—	450	—	490	μA
3-State Leakage Current I _{OZ}	V _{IL} or V _{IH}	V _O =V _{CC} or Gnd	6	—	—	±0.5	—	±5	—	±10	V _{IL} or V _{IH}	5.5	—	—	±0.5	—	±5	—	±10	—	μA

* For dual-supply systems theoretical worst case (V_I = 2.4 V, V_{CC} = 5.5 V) specification is 1.8 mA.

HCT Input Loading Table

Input	Unit Loads*
nA, nOE	1

*Unit Load is ΔI_{CC} limit specified in Static Characteristics Chart, e.g., 360 μA max. @ 25°C.

CD54/74HC126 CD54/74HCT126

SWITCHING CHARACTERISTICS ($V_{CC}=5\text{ V}$, $T_A=25^\circ\text{C}$, Input t_r , $t_f=6\text{ ns}$)

CHARACTERISTIC	C_L pF	SYMBOL	TYPICAL		UNITS
			HC	HCT	
Propagation Delay Data to Outputs	15	t_{PHL}, t_{PLH}	8	9	ns
Output Enabling Time	15	t_{PZL}, t_{PZH}	10	10	
Output Disabling Time	15	t_{PLZ}, t_{PHZ}	10	11	
Power Dissipation Capacitance*	—	C_{PD}	30	36	pF

* C_{PD} is used to determine the dynamic power consumption, per multiplexer.
 $P_D = V_{CC}^2 \cdot f_i (C_{PD} + C_L)$ where: f_i =input frequency
 C_L =load capacitance
 V_{CC} =supply voltage

SWITCHING CHARACTERISTICS ($C_L=50\text{ pF}$, Input $t_r, t_f=6\text{ ns}$)

CHARACTERISTIC	SYMBOL	V_{CC}	25°C				-40°C to +85°C				-55°C to +125°C				UNITS
			HC		HCT		74HC		74HCT		54HC		54HCT		
			Min.	Max.	Min.	Max.	Min.	Max.	Min.	Max.	Min.	Max.	Min.	Max.	
Propagation Delay Data to Outputs	t_{PLH}	2	—	100	—	—	—	125	—	—	—	150	—	—	ns
	t_{PHL}	4.5	—	20	—	24	—	25	—	30	—	30	—	36	
		6	—	17	—	—	—	21	—	—	—	36	—	—	
Enable Delay Times	t_{PZH}	2	—	125	—	—	—	155	—	—	—	190	—	—	ns
	t_{PZL}	4.5	—	25	—	25	—	31	—	31	—	38	—	38	
		6	—	21	—	—	—	26	—	—	—	32	—	—	
Disable Delay Times	t_{PHZ}	2	—	125	—	—	—	155	—	—	—	190	—	—	ns
	t_{PLZ}	4.5	—	25	—	28	—	31	—	35	—	38	—	42	
		6	—	21	—	—	—	26	—	—	—	32	—	—	
Output Transition Time	t_{TLH}	2	—	60	—	—	—	75	—	—	—	90	—	—	ns
	t_{THL}	4.5	—	12	—	12	—	15	—	15	—	18	—	18	
		6	—	10	—	—	—	13	—	—	—	15	—	—	
Input Capacitance	C_i	—	—	10	—	10	—	10	—	10	—	10	—	10	pF
3-State Output Capacitance	C_o	—	—	20	—	20	—	20	—	20	—	20	—	20	

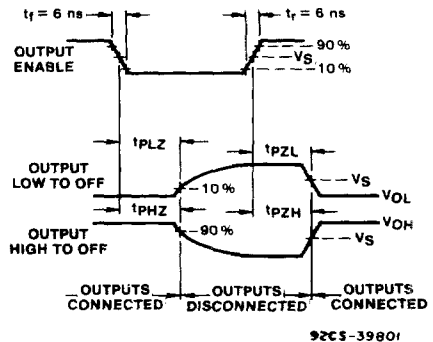
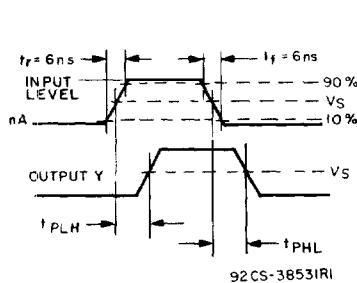

	54/74HC	54/74HCT
Input Level	V_{CC}	3 V
Switching Voltage, V_s	50% V_{CC}	1.3 V

Fig. 2 — Transition and propagation delay times.

CD54/74HC126 CD54/74HCT126

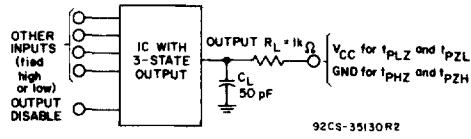

Fig. 3 - Three-state propagation delay test circuit.