



MT58LC128K36D7  
128K x 36 SYNCBURST™ SRAM

NEW  
SYNCHRONOUS PIPELINED SRAM

# SYNCHRONOUS SRAM

# 128K x 36 SRAM

+3.3V SUPPLY, PIPELINED, SINGLE CYCLE DESELECT AND SELECTABLE BURST MODE

## FEATURES

- Fast access times: 4.5, 5, 6, 7 and 8ns
- Fast OE access times: 5 and 6ns
- Single +3.3V +10%/-5% power supply
- SNOOZE MODE for reduced power standby
- Single cycle disable (Pentium™ BSRAM compatible)
- Common data inputs and data outputs
- Individual BYTE WRITE control and GLOBAL WRITE
- Three chip enables for simple depth expansion and address pipelining
- Clock controlled, registered, address, data I/O and control for fully pipelined applications
- Internally self-timed WRITE cycle
- WRITE pass-through capability
- Burst control pin (interleaved or linear burst)
- Automatic power-down for portable applications
- 100-lead TQFP package for high density, high speed
- Low capacitive bus loading
- High 30pF output drive capability at rated access time
- DIMMs also available

## OPTIONS

- Timing
  - 4.5ns access/8ns cycle -4.5
  - 5ns access/10ns cycle -5
  - 6ns access/12ns cycle -6
  - 7ns access/15ns cycle -7
  - 8ns access/20ns cycle -8
- Packages
  - 100-pin TQFP LG
- Low power P
- 2V data retention, low power L
- Part Number Example: MT58LC128K36D7LG-7P

## MARKING

## GENERAL DESCRIPTION

The Micron SyncBurst™ SRAM family employs high-speed, low-power CMOS designs using a four-transistor memory cell. Micron SRAMs are fabricated using an advanced CMOS process.

The MT58LC128K36D7 SRAM integrates a 128K x 36 SRAM core with advanced synchronous peripheral circuitry and a 2-bit burst counter. All synchronous inputs pass through registers controlled by a positive-edge-triggered single clock input (CLK). The synchronous inputs include all addresses, all data inputs, active LOW chip enable ( $\overline{CE}$ ), two additional chip enables for easy depth expansion ( $\overline{CE2}$ ,

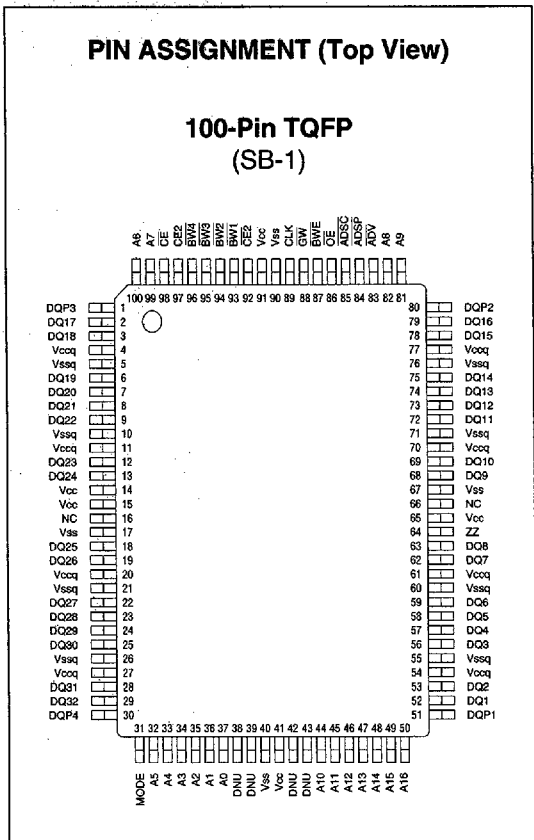

$\overline{CE2}$ ), burst control inputs ( $\overline{ADSC}$ ,  $\overline{ADSP}$ ,  $\overline{ADV}$ ), byte write enables ( $\overline{BWT}$ ,  $\overline{BW2}$ ,  $\overline{BW3}$ ,  $\overline{BW4}$ ,  $\overline{BWE}$ ) and global write ( $\overline{GW}$ ).

Asynchronous inputs include the output enable ( $\overline{OE}$ ), clock (CLK), snooze enable (ZZ) and burst mode (MODE). The data-out (Q), enabled by  $\overline{OE}$ , is also asynchronous. WRITE cycles can be from 1 to 4 bytes wide as controlled by the write control inputs.

Burst operation can be initiated with either address status processor ( $\overline{ADSP}$ ) or address status controller ( $\overline{ADSC}$ ) input pins. Subsequent burst addresses can be internally generated as controlled by the burst advance pin ( $\overline{ADV}$ ).

**GENERAL DESCRIPTION (continued)**

Address and write control are registered on-chip to simplify WRITE cycles. This allows self-timed WRITE cycles. Individual byte enables allow individual bytes to be written.  $\overline{BW1}$  controls DQ1-DQ8 and DQP1,  $\overline{BW2}$  controls DQ9-DQ16 and DQP2,  $\overline{BW3}$  controls DQ17-DQ24 and DQP3, and  $\overline{BW4}$  controls DQ25-DQ32 and DQP4, conditioned by  $\overline{BWE}$  being LOW.  $\overline{GW}$  LOW causes all bytes to be written. WRITE pass-through makes written data immediately available at the output register during the READ cycle following a WRITE as controlled solely by  $\overline{OE}$  to improve cache system response. The device incorporates an additional pipelined enable register to allow depth expansion without penalizing system performance.

The "L" version of this device has a data retention option which is useful for battery backup mode of operation. Although the part is not guaranteed to operate functionally below  $V_{CC\ MIN}$ , it will retain data with a minimum of power dissipation.

The MT58LC128K36D7 operates from a +3.3V power supply and all inputs and outputs are TTL-compatible. The device is ideally suited for Pentium and PowerPC™ pipelined systems and systems that benefit from a very wide high-speed data bus. The device is also ideal in generic 36- and 72-bit-wide applications.

**FUNCTIONAL BLOCK DIAGRAM**

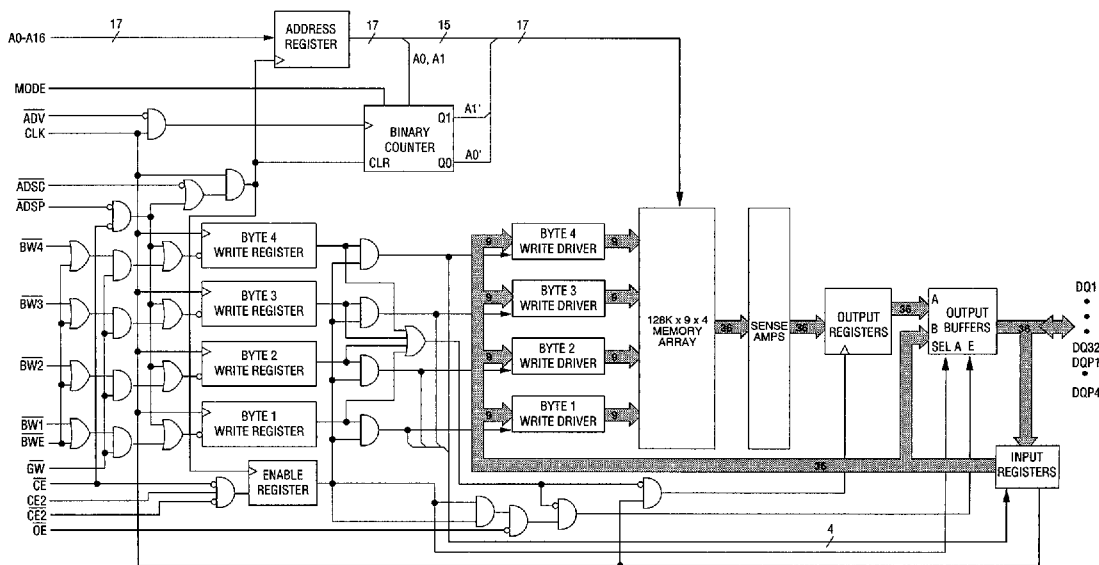

**NOTE:** 1. The Functional Block Diagram illustrates simplified device operation. See Truth Table, Pin Descriptions and timing diagrams for detailed information.

## PIN DESCRIPTIONS

TQFP PIN NUMBERS	SYMBOL	TYPE	DESCRIPTION
37, 36, 35, 34, 33, 32, 100, 99, 82, 81, 44, 45, 46, 47, 48, 49, 50	A0-A16	Input	Synchronous Address Inputs: These inputs are registered and must meet the setup and hold times around the rising edge of CLK.
93, 94, 95, 96	$\overline{BW1}$ , $\overline{BW2}$ , $\overline{BW3}$ , $\overline{BW4}$	Input	Synchronous Byte Write Enables: These active LOW inputs allow individual bytes to be written when $\overline{BWE}$ is LOW and must meet the setup and hold times around the rising edge of CLK. A Byte Write Enable is LOW for a WRITE cycle and HIGH for a READ cycle. $\overline{BW1}$ controls DQ1-DQ8 and DQP1. $\overline{BW2}$ controls DQ9-DQ16 and DQP2. $\overline{BW3}$ controls DQ17-DQ24 and DQP3. $\overline{BW4}$ controls DQ25-DQ32 and DQP4. Data I/O are tristated if any of these four inputs are LOW.
89	CLK	Input	Clock: This signal registers the address, data, chip enables, byte write enables and burst control inputs on its rising edge. All synchronous inputs must meet setup and hold times around the clock's rising edge.
98	$\overline{CE}$	Input	Synchronous Chip Enable: This active LOW input is used to enable the device and conditions internal use of $\overline{ADSP}$ . This input is sampled only when a new external address is loaded.
92	$\overline{CE2}$	Input	Synchronous Chip Enable: This active LOW input is used to enable the device. This input is sampled only when a new external address is loaded. This input can be used for memory depth expansion.
97	CE2	Input	Synchronous Chip Enable: This active HIGH input is used to enable the device. This input is sampled only when a new external address is loaded. This input can be used for memory depth expansion.
86	$\overline{OE}$	Input	Output Enable: This active LOW asynchronous input enables the data I/O output drivers.
83	ADV	Input	Synchronous Address Advance: This active LOW input is used to advance the internal burst counter, controlling burst access after the external address is loaded. A HIGH on this pin effectively causes wait states to be generated (no address advance). This pin must be HIGH at the rising edge of the first clock after an $\overline{ADSP}$ cycle is initiated if a WRITE cycle is desired (to ensure use of correct address).
84	$\overline{ADSP}$	Input	Synchronous Address Status Processor: This active LOW input interrupts any ongoing burst, causing a new external address to be registered. A READ is performed using the new address, independent of the byte write enables and $\overline{ADSC}$ but dependent upon CE2 and $\overline{CE2}$ . $\overline{ADSP}$ is ignored if $\overline{CE}$ is HIGH. Power-down state is entered if CE2 is LOW or $\overline{CE2}$ is HIGH.
85	$\overline{ADSC}$	Input	Synchronous Address Status Controller: This active LOW input interrupts any ongoing burst and causes a new external address to be registered. A READ or WRITE is performed using the new address if all chip enables are active. Power-down state is entered if one or more chip enables are inactive.

**PIN DESCRIPTIONS (continued)**

TQFP PIN NUMBERS	SYMBOL	TYPE	DESCRIPTION
87	$\overline{BWE}$	Input	Byte Write Enable: This active LOW input permits byte write operations and must meet the setup and hold times around the rising edge of CLK.
88	$\overline{GW}$	Input	Global Write: This active LOW input allows a full 36-bit WRITE to occur independent of the $\overline{BWE}$ and $\overline{BWN}$ lines and must meet the setup and hold times around the rising edge of CLK.
64	$\overline{ZZ}$	Input	Snooze Enable: This active HIGH asynchronous input causes the device to enter a low-power standby mode in which all data in the memory array is retained.
16, 66	NC	-	No Connect: These signals are not internally connected. These signals may be connected to ground to improve package heat dissipation.
38, 39, 42, 43	DNU	-	Do Not Use: These signals must not be connected.
52, 53, 56, 57, 58, 59, 62, 63, 68, 69, 72, 73, 74, 75, 78, 79, 2, 3, 6, 7, 8, 9, 12, 13, 18, 19, 22, 23, 24, 25, 28, 29	DQ1-DQ32	Input/Output	SRAM Data I/O: Byte 1 is DQ1-DQ8; Byte 2 is DQ9-DQ16; Byte 3 is DQ17-DQ24; Byte 4 is DQ25-DQ32. Input data must meet setup and hold times around the rising edge of CLK.
51, 80, 1, 30	DQP1-DQP4	Input/Output	Parity Data I/O: Byte 1 Parity is DQP1; Byte 2 Parity is DQP2; Byte 3 Parity is DQP3; Byte 4 Parity is DQP4.
31	MODE	Input	Mode: This input selects the burst sequence. A LOW on this pin selects LINEAR BURST. A NC or HIGH on this pin selects INTERLEAVED BURST. Do not alter input state while device is operating.
4, 11, 14, 15, 20, 27, 41, 54, 61, 65, 70, 77, 91	Vcc	Supply	Power Supply: +3.3V +10%/-5%
5, 10, 17, 21, 26, 40, 55, 60, 67, 71, 76, 90	Vss	Supply	Ground: GND

**PASS-THROUGH TRUTH TABLE**

PREVIOUS CYCLE <sup>1</sup>		PRESENT CYCLE				NEXT CYCLE
OPERATION	$\overline{BWs}$	OPERATION	$\overline{CE}$	$\overline{BWs}$	$\overline{OE}$	OPERATION
Initiate WRITE cycle, all bytes Address = A(n-1), data = D(n-1)	All L <sup>2,3</sup>	Initiate READ cycle Register A(n), Q = D(n-1)	L	H	L	Read D(n)
Initiate WRITE cycle, all bytes Address = A(n-1), data = D(n-1)	All L <sup>2,3</sup>	No new cycle Q = D(n-1)	H	H	L	No carry-over from previous cycle
Initiate WRITE cycle, all bytes Address = A(n-1), data = D(n-1)	All L <sup>2,3</sup>	No new cycle Q = HIGH-Z	H	H	H	No carry-over from previous cycle
Initiate WRITE cycle, one byte Address = A(n-1), data = D(n-1)	One L <sup>2</sup>	No new cycle Q = D(n-1) for one byte	H	H	L	No carry-over from previous cycle

- NOTE:**
1. Previous cycle may be either BURST or NONBURST cycle.
  2.  $\overline{BWE}$  is LOW when one or more  $\overline{BWN}$  is LOW.
  3.  $\overline{GW}$  LOW will yield identical results.



**INTERLEAVED BURST ADDRESS TABLE (MODE = NC OR HIGH)**

First Address (External)	Second Address (Internal)	Third Address (Internal)	Fourth Address (Internal)
X...X00	X...X01	X...X10	X...X11
X...X01	X...X00	X...X11	X...X10
X...X10	X...X11	X...X00	X...X01
X...X11	X...X10	X...X01	X...X00

**LINEAR BURST ADDRESS TABLE (MODE = GND)**

First Address (External)	Second Address (Internal)	Third Address (Internal)	Fourth Address (Internal)
X...X00	X...X01	X...X10	X...X11
X...X01	X...X10	X...X11	X...X00
X...X10	X...X11	X...X00	X...X01
X...X11	X...X00	X...X01	X...X10

**PARTIAL TRUTH TABLE FOR WRITE COMMANDS**

Function	GW	BWE	BWT	BW2	BW3	BW4
READ	H	H	X	X	X	X
READ	H	L	H	H	H	H
WRITE Byte 1	H	L	L	H	H	H
WRITE all bytes	H	L	L	L	L	L
WRITE all bytes	L	X	X	X	X	X

**NOTE:** Using BWE and BWT through BW4, any one or more bytes may be written.

**TRUTH TABLE**

OPERATION	ADDRESS USED	CE	CE2	CE2	ZZ	ADSP	ADSC	ADV	WRITE	OE	CLK	DQ
Deselected Cycle, Power-down	None	H	X	X	L	X	L	X	X	X	L-H	High-Z
Deselected Cycle, Power-down	None	L	X	L	L	L	X	X	X	X	L-H	High-Z
Deselected Cycle, Power-down	None	L	H	X	L	L	X	X	X	X	L-H	High-Z
Deselected Cycle, Power-down	None	L	X	L	L	H	L	X	X	X	L-H	High-Z
Deselected Cycle, Power-down	None	L	H	X	L	H	L	X	X	X	L-H	High-Z
SNOOZE MODE, Power-down	None	X	X	X	H	X	X	X	X	X	X	High-Z
READ Cycle, Begin Burst	External	L	L	H	L	L	X	X	X	L	L-H	Q
READ Cycle, Begin Burst	External	L	L	H	L	L	X	X	X	H	L-H	High-Z
WRITE Cycle, Begin Burst	External	L	L	H	L	H	L	X	L	X	L-H	D
READ Cycle, Begin Burst	External	L	L	H	L	H	L	X	H	L	L-H	Q
READ Cycle, Begin Burst	External	L	L	H	L	H	L	X	H	H	L-H	High-Z
READ Cycle, Continue Burst	Next	X	X	X	L	H	H	L	H	L	L-H	Q
READ Cycle, Continue Burst	Next	X	X	X	L	H	H	L	H	H	L-H	High-Z
READ Cycle, Continue Burst	Next	H	X	X	L	X	H	L	H	L	L-H	Q
READ Cycle, Continue Burst	Next	H	X	X	L	X	H	L	H	H	L-H	High-Z
WRITE Cycle, Continue Burst	Next	X	X	X	L	H	H	L	L	X	L-H	D
WRITE Cycle, Continue Burst	Next	H	X	X	L	X	H	L	L	X	L-H	D
READ Cycle, Suspend Burst	Current	X	X	X	L	H	H	H	H	L	L-H	Q
READ Cycle, Suspend Burst	Current	X	X	X	L	H	H	H	H	H	L-H	High-Z
READ Cycle, Suspend Burst	Current	H	X	X	L	X	H	H	H	L	L-H	Q
READ Cycle, Suspend Burst	Current	H	X	X	L	X	H	H	H	H	L-H	High-Z
WRITE Cycle, Suspend Burst	Current	X	X	X	L	H	H	H	L	X	L-H	D
WRITE Cycle, Suspend Burst	Current	H	X	X	L	X	H	H	L	X	L-H	D

- NOTE:**
1. X means "don't care." H means logic HIGH. L means logic LOW.  $\overline{\text{WRITE}}=\text{L}$  means any one or more byte write enable signals ( $\overline{\text{BW1}}$ ,  $\overline{\text{BW2}}$ ,  $\overline{\text{BW3}}$  or  $\overline{\text{BW4}}$ ) and  $\overline{\text{BWE}}$  are LOW or  $\overline{\text{GW}}$  is LOW.  $\overline{\text{WRITE}}=\text{H}$  means all byte write enable signals are HIGH.
  2.  $\overline{\text{BW1}}$  enables WRITES to Byte 1 (DQ1-DQ8, DQP1).  $\overline{\text{BW2}}$  enables WRITES to Byte 2 (DQ9-DQ16, DQP2).  $\overline{\text{BW3}}$  enables WRITES to Byte 3 (DQ17-DQ24, DQP3).  $\overline{\text{BW4}}$  enables WRITES to Byte 4 (DQ25-DQ32, DQP4).
  3. All inputs except  $\overline{\text{OE}}$  must meet setup and hold times around the rising edge (LOW to HIGH) of CLK.
  4. Wait states are inserted by suspending burst.
  5. For a WRITE operation following a READ operation,  $\overline{\text{OE}}$  must be HIGH before the input data required setup time and held HIGH throughout the input data hold time.
  6. This device contains circuitry that will ensure the outputs will be in High-Z during power-up.
  7.  $\overline{\text{ADSP}}$  LOW always initiates an internal READ at the L-H edge of CLK. A WRITE is performed by setting one or more byte write enable signals and  $\overline{\text{BWE}}$  LOW or  $\overline{\text{GW}}$  LOW for the subsequent L-H edge of CLK. Refer to WRITE timing diagram for clarification.



**MT58LC128K36D7**  
**128K x 36 SYNCBURST™ SRAM**

**NEW SYNCHRONOUS PIPELINED SRAM**

**ABSOLUTE MAXIMUM RATINGS\***

Voltage on Vcc Supply Relative to Vss .....	-0.5V to +4.6V
V <sub>IN</sub> .....	-0.5V to V <sub>CC</sub> +0.5V
Storage Temperature (plastic) .....	-55°C to +150°C
Junction Temperature** .....	+150°C
Short Circuit Output Current .....	100mA

\*Stresses greater than those listed under "Absolute Maximum Ratings" may cause permanent damage to the device. This is a stress rating only and functional operation of the device at these or any other conditions above those indicated in the operational sections of this specification is not implied. Exposure to absolute maximum rating conditions for extended periods may affect reliability.

\*\*Maximum junction temperature depends upon package type, cycle time, loading, ambient temperature and airflow. See technical note TN-05-14 for more information.

**ELECTRICAL CHARACTERISTICS AND RECOMMENDED DC OPERATING CONDITIONS**

(0°C ≤ T<sub>A</sub> ≤ 70°C; V<sub>CC</sub> = +3.3V ±10%/±5% unless otherwise noted)

DESCRIPTION	CONDITIONS	SYMBOL	MIN	MAX	UNITS	NOTES
Input High (Logic 1) Voltage		V <sub>IH</sub>	2.0	V <sub>CC</sub> +0.3	V	1, 2
Input High (Logic 1) Voltage	For MODE and ZZ	V <sub>IH</sub>	2.4	V <sub>CC</sub> +0.3	V	1, 2
Input Low (Logic 0) Voltage		V <sub>IL</sub>	-0.3	0.8	V	1, 2
Input Leakage Current	0V ≤ V <sub>IN</sub> ≤ V <sub>CC</sub>	I <sub>LI</sub>	-1	1	μA	14
Output Leakage Current	Output(s) disabled, 0V ≤ V <sub>OUT</sub> ≤ V <sub>CC</sub>	I <sub>LO</sub>	-1	1	μA	
Output High Voltage	I <sub>OH</sub> = -4.0mA	V <sub>OH</sub>	2.4		V	1, 11
Output Low Voltage	I <sub>OL</sub> = 8.0mA	V <sub>OL</sub>		0.4	V	1, 11
Supply Voltage		V <sub>CC</sub>	3.135	3.6	V	1

DESCRIPTION	CONDITIONS	SYM	VER	TYP	MAX					UNITS	NOTES
					-4.5	-5	-6	-7	-8		
Power Supply Current: Operating	Device selected; all inputs ≤ V <sub>IL</sub> or ≥ V <sub>IH</sub> ; cycle time ≥ 1/4 KC MIN; V <sub>CC</sub> = MAX; outputs open	I <sub>CC</sub>	ALL	200	500	425	375	325	275	mA	3, 12, 13
Power Supply Current: Idle	Device selected; V <sub>CC</sub> = MAX; ADSC, ADSP, GW, BWS, ADV ≥ V <sub>IH</sub> ; all inputs ≤ V <sub>SS</sub> +0.2 or ≥ V <sub>CC</sub> -0.2; cycle time ≥ 1/4 KC MIN	I <sub>CC1</sub>	ALL	30	81	81	76	66	51	mA	12, 13
CMOS Standby	Device deselected; V <sub>CC</sub> = MAX; all inputs ≤ V <sub>SS</sub> +0.2 or ≥ V <sub>CC</sub> -0.2; all inputs static; CLK frequency = 0	I <sub>SB2</sub>	STD	0.5	5	5	5	5	5	mA	12, 13
			P	0.2	2	2	2	2	2	mA	
TTL Standby	Device deselected; V <sub>CC</sub> = MAX; all inputs ≤ V <sub>IL</sub> or ≥ V <sub>IH</sub> ; all inputs static; CLK frequency = 0	I <sub>SB3</sub>	STD	15	25	25	25	25	25	mA	12, 13
			P	8	18	18	18	18	18	mA	
Clock Running	Device deselected; V <sub>CC</sub> = MAX; all inputs ≤ V <sub>SS</sub> +0.2 or ≥ V <sub>CC</sub> -0.2; CLK cycle time ≥ 1/4 KC MIN	I <sub>SB4</sub>	ALL	30	81	81	76	66	51	mA	12, 13

## CAPACITANCE

DESCRIPTION	CONDITIONS	SYMBOL	TYP	MAX	UNITS	NOTES
Control Input Capacitance	$T_A = 25^\circ\text{C}; f = 1 \text{ MHz}$ $V_{CC} = 3.3\text{V}$	$C_i$	3	4	pF	4
Input/Output Capacitance (DQ)		$C_o$	6	8	pF	4
Address and Clock Input Capacitance		$C_A$	2.5	3	pF	4

## THERMAL CONSIDERATIONS

DESCRIPTION	CONDITIONS	SYMBOL	TYP	UNITS	NOTES
Thermal resistance - Junction to Ambient	Still Air, Soldered on 4.25 x 1.125 inch 4-layer circuit board	$\theta_{JA}$	20	$^\circ\text{C/W}$	
Thermal resistance - Junction to Case		$\theta_{JC}$	1	$^\circ\text{C/W}$	

## ELECTRICAL CHARACTERISTICS AND RECOMMENDED AC OPERATING CONDITIONS

(Note 5) ( $0^\circ\text{C} \leq T_A \leq 70^\circ\text{C}; V_{CC} = +3.3\text{V} \pm 10\%/ -5\%$ )

DESCRIPTION	SYM	-4.5		-5		-6		-7		-8		UNITS	NOTES
		MIN	MAX	MIN	MAX	MIN	MAX	MIN	MAX	MIN	MAX		
<b>Clock</b>													
Clock cycle time	$t_{KC}$	8		10		12		15		20		ns	
Clock HIGH time	$t_{KH}$	3		4		4.5		5		6		ns	
Clock LOW time	$t_{KL}$	3		4		4.5		5		6		ns	
<b>Output Times</b>													
Clock to output valid	$t_{KQ}$		4.5		5		6		7		8	ns	
Clock to output invalid	$t_{KQX}$	2		2		2		2		2		ns	
Clock to output in Low-Z	$t_{KQLZ}$	2		2		2		2		2		ns	4, 6, 7
Clock to output in High-Z	$t_{KQHZ}$		4.5		5		5		6		6	ns	4, 6, 7
$\overline{\text{OE}}$ to output valid	$t_{\text{OEQ}}$		4.5		5		5		5		6	ns	9
$\overline{\text{OE}}$ to output in Low-Z	$t_{\text{OELZ}}$	0		0		0		0		0		ns	4, 6, 7
$\overline{\text{OE}}$ to output in High-Z	$t_{\text{OEHZ}}$		3		4		5		6		6	ns	4, 6, 7
<b>Setup Times</b>													
Address	$t_{AS}$	2.5		2.5		2.5		2.5		3.5		ns	8, 10
Address Status (ADSC, ADSP)	$t_{ADSS}$	2.5		2.5		2.5		2.5		3.5		ns	8, 10
Address Advance (ADV)	$t_{AAS}$	2.5		2.5		2.5		2.5		3.5		ns	8, 10
Write Signals (BW1, BW2, BW3, BW4, BWE, GW)	$t_{WS}$	2.5		2.5		2.5		2.5		3.5		ns	8, 10
Data-in	$t_{DS}$	2.5		2.5		2.5		2.5		3.5		ns	8, 10
Chip Enables ( $\overline{\text{CE}}$ , $\overline{\text{CE2}}$ , CE2)	$t_{CES}$	2.5		2.5		2.5		2.5		3.5		ns	8, 10
<b>Hold Times</b>													
Address	$t_{AH}$	0.5		0.5		0.5		0.5		0.8		ns	8, 10
Address Status (ADSC, ADSP)	$t_{ADSH}$	0.5		0.5		0.5		0.5		0.8		ns	8, 10
Address Advance (ADV)	$t_{AAH}$	0.5		0.5		0.5		0.5		0.8		ns	8, 10
Write Signals (BW1, BW2, BW3, BW4, BWE, GW)	$t_{WH}$	0.5		0.5		0.5		0.5		0.8		ns	8, 10
Data-in	$t_{DH}$	0.5		0.5		0.5		0.5		0.8		ns	8, 10
Chip Enables ( $\overline{\text{CE}}$ , $\overline{\text{CE2}}$ , CE2)	$t_{CEH}$	0.5		0.5		0.5		0.5		0.8		ns	8, 10



**AC TEST CONDITIONS**

Input pulse levels .....	Vss to 3.0V
Input rise and fall times .....	2.5ns
Input timing reference levels .....	1.5V
Output reference levels .....	1.5V
Output load .....	See Figures 1 and 2

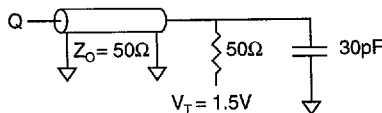

Fig. 1 OUTPUT LOAD EQUIVALENT

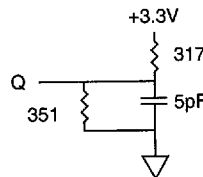

Fig. 2 OUTPUT LOAD EQUIVALENT

**NOTES**

- All voltages referenced to Vss (GND).
- Overshoot:  $V_{IH} \leq +4.6V$  for  $t \leq {}^tKC / 2$  for  $I \leq 20mA$ .  
Undershoot:  $V_{IL} \geq -0.7V$  for  $t \leq {}^tKC / 2$  for  $I \leq 20mA$ .  
Power-up:  $V_{IH} \leq +3.6V$  and  $V_{CC} \leq 3.135V$  for  $t \leq 200ms$ .
- Icc is given with no output current. Icc increases with greater output loading and faster cycle times.
- This parameter is sampled.
- Test conditions as specified with the output loading as shown in Fig. 1 unless otherwise noted.
- Output loading is specified with  $C_L = 5pF$  as in Fig. 2. Transition is measured  $\pm 500mV$  from steady state voltage.
- At any given temperature and voltage condition,  ${}^tKQHZ$  is less than  ${}^tKQLZ$  and  ${}^tOEHZ$  is less than  ${}^tOELZ$ .
- A WRITE cycle is defined by at least one byte write enable LOW and  $\overline{ADSP}$  HIGH for the required setup and hold times. A READ cycle is defined by all byte write enables HIGH and ( $\overline{ADSC}$  or  $\overline{ADV}$  LOW) or  $\overline{ADSP}$  LOW for the required setup and hold times.
- $\overline{OE}$  is a "don't care" when a byte write enable is sampled LOW.
- This is a synchronous device. All addresses must meet the specified setup and hold times for all rising edges of CLK when either  $\overline{ADSP}$  or  $\overline{ADSC}$  is LOW and chip enabled. All other synchronous inputs must meet the setup and hold times with stable logic levels for all rising edges of clock (CLK) when the chip is enabled. Chip enable must be valid at each rising edge of CLK (when either  $\overline{ADSP}$  or  $\overline{ADSC}$  is LOW) to remain enabled.
- The load used for  $V_{OH}$ ,  $V_{OL}$  testing is shown in Fig. 2. AC load current is higher than the shown DC values. AC I/O curves are available upon request.
- "Device Deselected" means device is in POWER-DOWN mode as defined in the Truth Table. "Device Selected" means device is active (not in POWER-DOWN mode).
- Typical values are measured at 3.3V, 25°C and 20ns cycle time.
- MODE pin has an internal pull-up and exhibits an input leakage current of  $\pm 10\mu A$ .
- Typical values are measured at 25°C.
- The device must have a deselect cycle applied at least two clock cycles before data retention mode is entered.

DATA RETENTION ELECTRICAL CHARACTERISTICS (L version only)

DESCRIPTION	CONDITIONS	SYMBOL	MIN	MAX	UNITS	NOTES
V <sub>cc</sub> for Retention Data		V <sub>DR</sub>	2		V	
Data Retention Current Method 1	$\overline{CE}, \overline{CE2} \geq (V_{cc} - 0.2V), CE2 \leq 0.2V$ $V_{IN} \geq (V_{cc} - 0.2V) \text{ or } \leq 0.2V$ $V_{cc} = 2V, ZZ \leq 0.2V$	I <sub>CCDR</sub>		TBD	μA	15
Data Retention Current Method 2	$ZZ \geq -0.2V$ $V_{cc} = 2V$	I <sub>CCDR</sub>		TBD	μA	15
Chip Deselect to Data Retention Time		t <sub>CDR</sub>	2(t <sub>KC</sub> )		ns	4, 16
Operation Recovery Time		t <sub>R</sub>		2(t <sub>KC</sub> )	ns	4

LOW V<sub>cc</sub> DATA RETENTION WAVEFORM

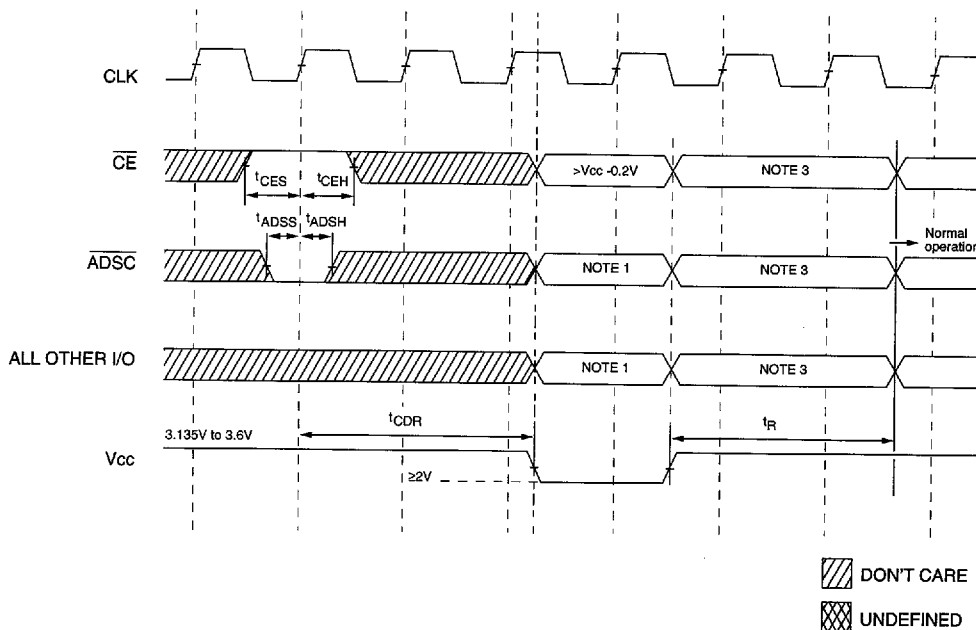

- NOTE:**
1. If ZZ is inactive ( $ZZ \leq 0.2V$ ),  $\overline{CE} > V_{cc} - 0.2V$  and other inputs must be  $\geq V_{cc} - 0.2V$  or  $\leq 0.2V$  to guarantee I<sub>CCDR</sub> in data retention mode. If inputs are between these levels or left floating, I<sub>CCDR</sub> may be exceeded. If ZZ is active ( $ZZ \geq V_{cc} - 0.2V$ ), then this restriction on input may be ignored.
  2. Only one of the available deselect cycle sequences is shown above ( $\overline{CE} = \text{HIGH}, \overline{ADSC} = \text{LOW}$ ). Any of the other deselect cycle sequences may also be used.
  3. The device control signals should be in a deselect state between the rising edge of V<sub>cc</sub> and until t<sub>R</sub> is met.
  4. All inputs must be  $\leq V_{cc} + 0.3V$  while the device is in data retention mode.

**SNOOZE MODE**

SNOOZE MODE is a low current, "power down" mode in which the device is deselected and current is reduced to  $I_{SB2}$ . The duration of SNOOZE MODE is dictated by the length of time the ZZ pin is in a HIGH state. After entering SNOOZE MODE, the clock and all other inputs are ignored.

The ZZ pin (pin 64) is an asynchronous, active HIGH input that causes the device to enter SNOOZE MODE.

When the ZZ pin becomes a logic HIGH,  $I_{SB2}$  is guaranteed after the setup time  $t_{ZZ}$  is met. Any access pending when entering SNOOZE MODE is not guaranteed to successfully complete. Therefore, SNOOZE MODE must not be initiated until valid pending operations are completed.

**SNOOZE MODE ELECTRICAL CHARACTERISTICS**

DESCRIPTION	CONDITIONS	SYMBOL	MIN	MAX	UNITS	NOTES
Current during SNOOZE MODE	$ZZ \geq V_{IH}$	$I_{SB2}$		5	mA	
Current during SNOOZE MODE (P Version)	$ZZ \geq V_{IH}$	$I_{SB2}$		2	mA	
ZZ HIGH to SNOOZE MODE time		$t_{ZZ}$	$2(t_{KC})$		ns	4
SNOOZE MODE Operation Recovery Time		$t_{RZZ}$		$2(t_{KC})$	ns	4

**SNOOZE MODE WAVEFORM**

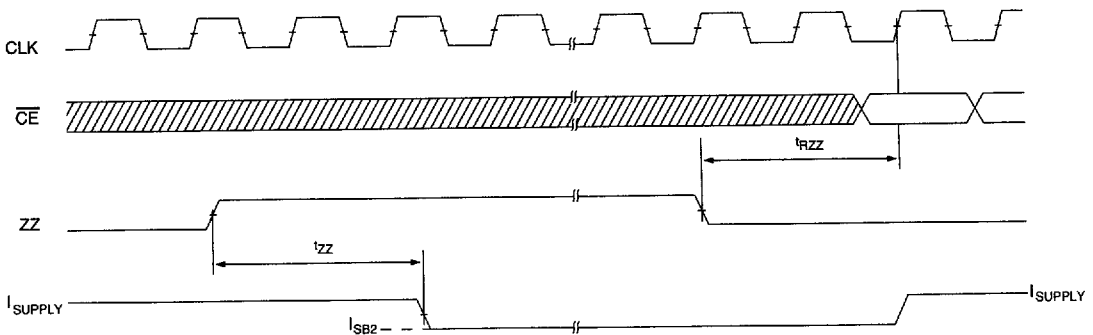

**NOTE:** 1. The  $\overline{CE}$  signal shown above refers to a TRUE state on all chip selects for the device.

**READ TIMING**

**NEW SYNCHRONOUS PIPELINED SRAM**

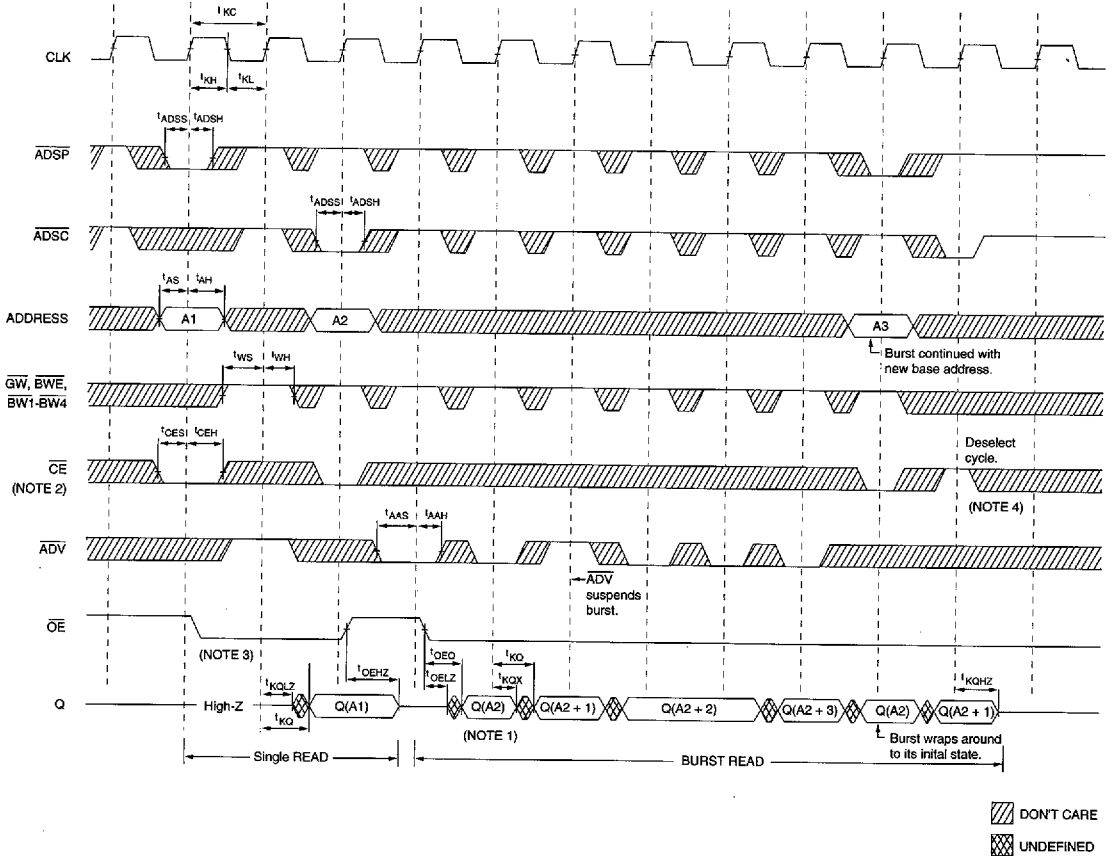

- NOTE:**
1. Q(A2) refers to output from address A2. Q(A2+1) refers to output from the next internal burst address following A2.
  2.  $\overline{CE2}$  and CE2 have timing identical to  $\overline{CE}$ . On this diagram, when  $\overline{CE}$  is LOW,  $\overline{CE2}$  is LOW and CE2 is HIGH. When  $\overline{CE}$  is HIGH,  $\overline{CE2}$  is HIGH and CE2 is LOW.
  3. Timing is shown assuming that the device was not enabled before entering into this sequence.  $\overline{OE}$  does not cause Q to be driven until after the following clock rising edge.
  4. Outputs are disabled within one clock cycle after deselect.

**WRITE TIMING**

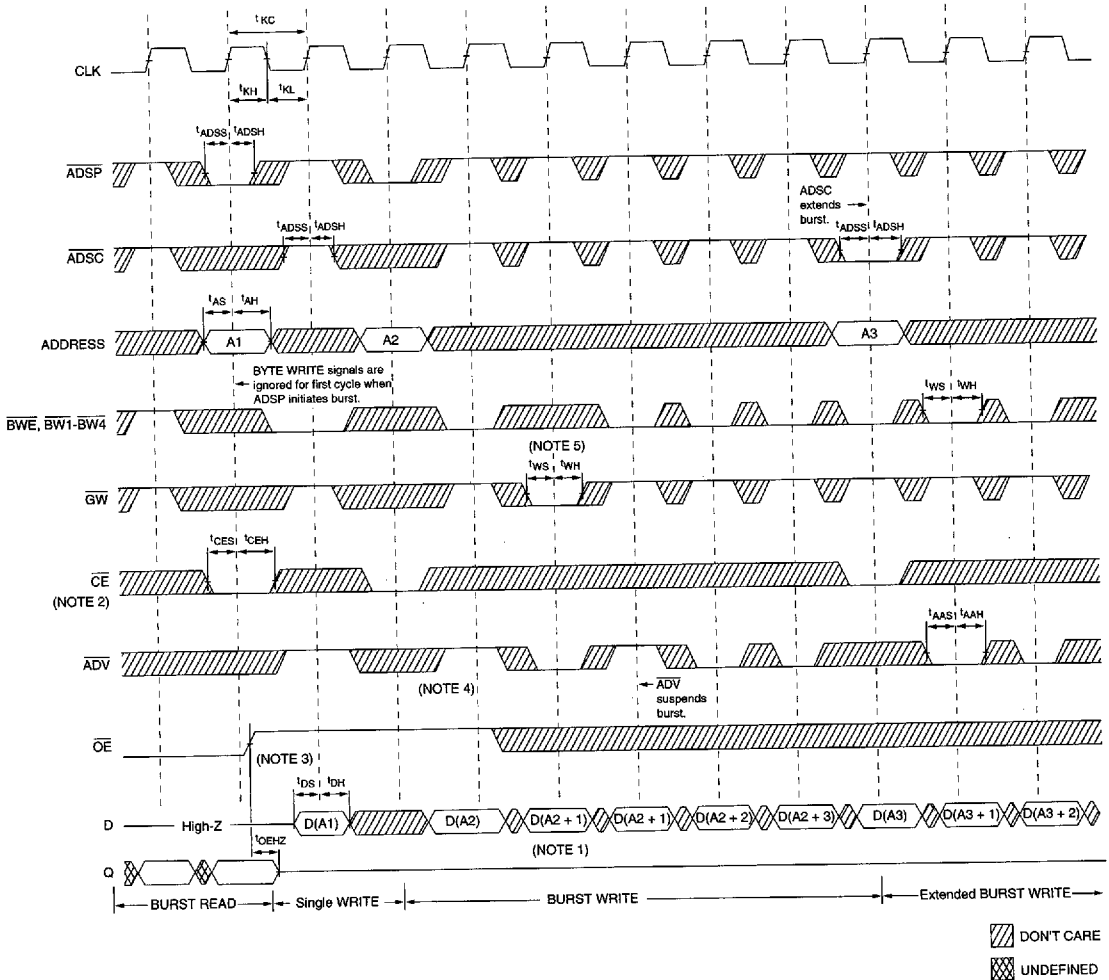

- NOTE:**
1. D(A2) refers to input for address A2. D(A2+1) refers to input for the next internal burst address following A2.
  2.  $\overline{CE2}$  and CE2 have timing identical to  $\overline{CE}$ . On this diagram, when  $\overline{CE}$  is LOW,  $\overline{CE2}$  is LOW and CE2 is HIGH. When  $\overline{CE}$  is HIGH,  $\overline{CE2}$  is HIGH and CE2 is LOW.
  3.  $\overline{OE}$  must be HIGH before the input data setup and held HIGH throughout the data hold time. This prevents input/output data contention for the time period prior to the byte write enable inputs being sampled.
  4.  $\overline{ADV}$  must be HIGH to permit a WRITE to the loaded address.
  5. Full width WRITE can be initiated by  $\overline{GW}$  LOW or  $\overline{GW}$  HIGH and  $\overline{BWE}$ ,  $\overline{BW1}$ -  $\overline{BW4}$  LOW.

READ/WRITE TIMING

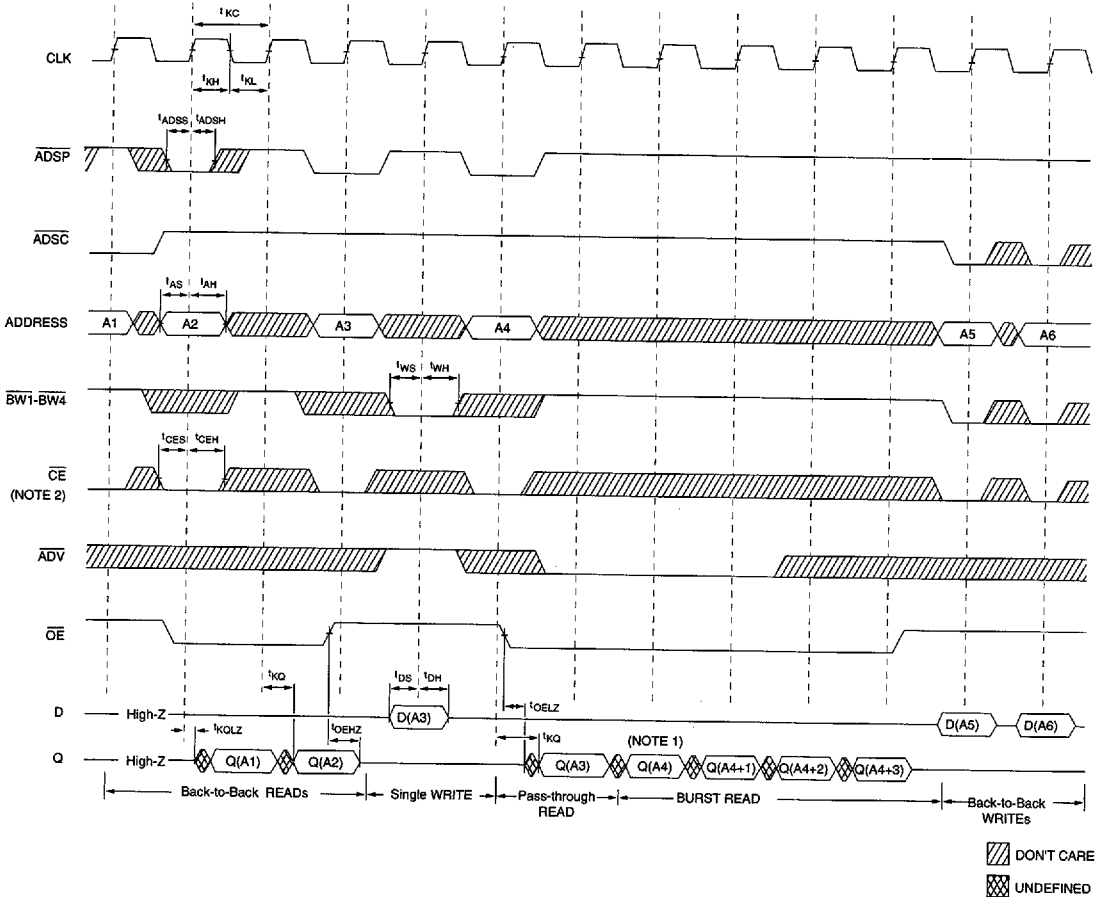

- NOTE:**
1. Q(A4) refers to output from address A4. Q(A4+1) refers to output from the next internal burst address following A4.
  2.  $\overline{CE2}$  and CE2 have timing identical to  $\overline{CE}$ . On this diagram, when  $\overline{CE}$  is LOW,  $\overline{CE2}$  is LOW and CE2 is HIGH. When  $\overline{CE}$  is HIGH,  $\overline{CE2}$  is HIGH and CE2 is LOW.
  3. The data bus (Q) remains in High-Z following a WRITE cycle unless an  $\overline{ADSP}$ ,  $\overline{ADSC}$  or  $\overline{ADV}$  cycle is performed.
  4.  $\overline{GW}$  is HIGH.
  5. Back-to-back READs may be controlled by either  $\overline{ADSP}$  or  $\overline{ADSC}$ .

## APPLICATION INFORMATION

### LOAD DERATING CURVES

The Micron 128K x 36 Synchronous SRAM timing is dependent upon the capacitive loading on the outputs. The data sheet is written assuming a load of 30pF. Access time changes with load capacitance as follows:

$$\Delta t_{KQ} = 0.016 \text{ ns/pF} \times \Delta C_L \text{ pF.}$$

(Note: this is preliminary information subject to change.)

For example, if the SRAM loading is 22pF,  $\Delta C_L$  is -8pF (8pF less than rated load). The clock to valid output time of the SRAM is reduced by  $0.016 \times 8 = 0.128\text{ns}$ . If the device is a 12ns part, the worst case  $t_{KQ}$  becomes 11.87ns (approximately).

Consult the factory for copies of I/O current versus voltage curves. For capacitive loading derating curves see technical note TN-05-20, "3.3V SRAM Capacitive Loading."

**52-PIN PLCC**  
**SA-1**

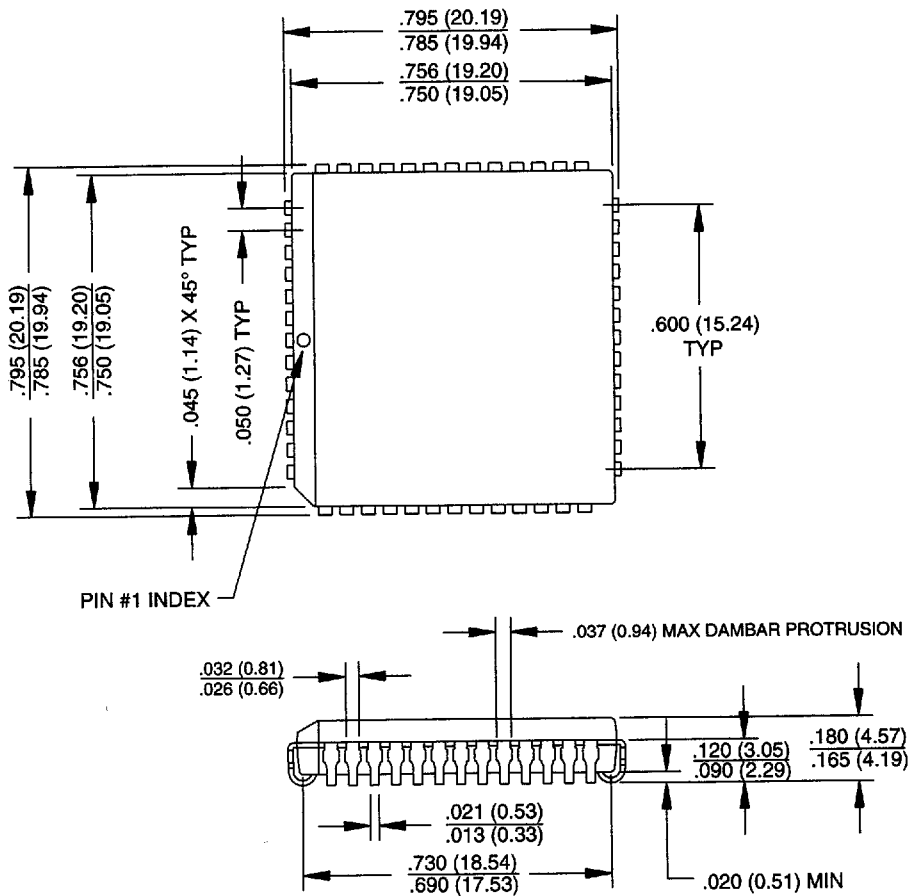

**PACKAGE INFORMATION**

- NOTE:**
1. All dimensions in inches (millimeters)  $\frac{\text{MAX}}{\text{MIN}}$  or typical where noted.
  2. Package width and length do not include mold protrusion; allowable mold protrusion is .01" per side.



**100-PIN TQFP**  
**SB-1**

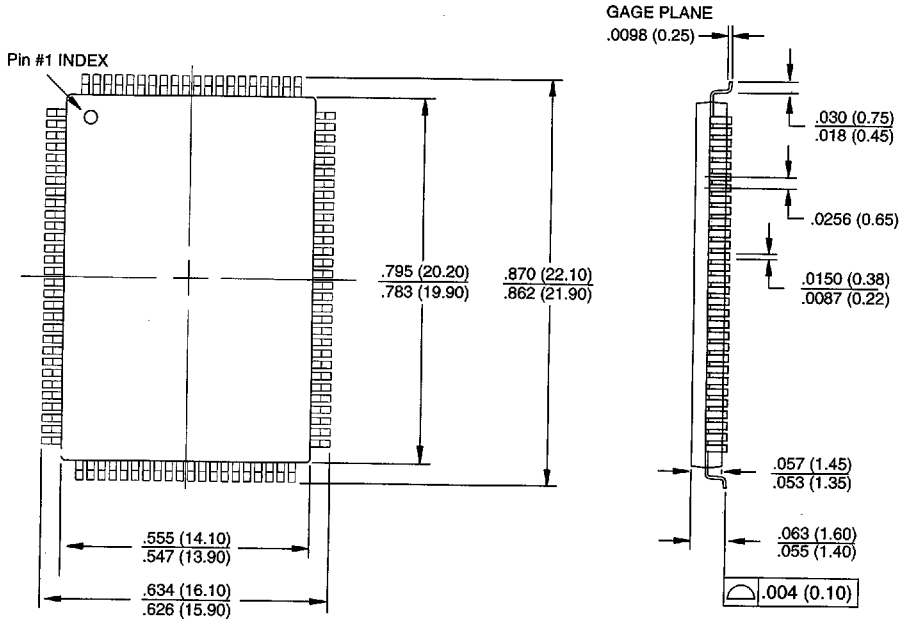

PACKAGE INFORMATION

- NOTE:**
1. All dimensions in inches (millimeters) <sup>MAX</sup> or typical where noted.  
MIN
  2. Package width and length do not include mold protrusion; allowable mold protrusion is .01" per side.

**28-PIN PLASTIC SOJ  
SC-1**

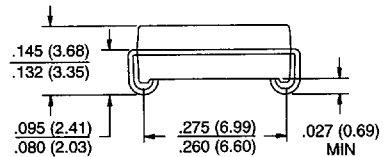
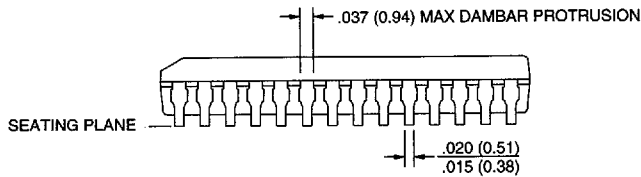
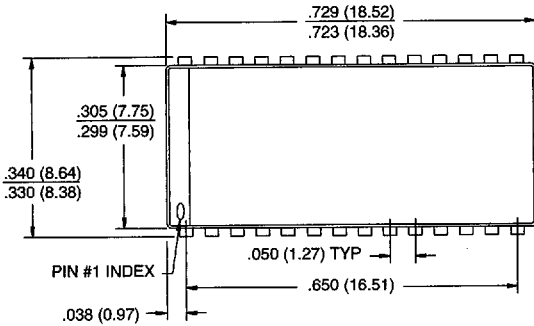

**PACKAGE INFORMATION**

- NOTE:**
1. All dimensions in inches (millimeters)  $\frac{\text{MAX}}{\text{MIN}}$  or typical where noted.
  2. Package width and length do not include mold protrusion; allowable mold protrusion is .01" per side.

**160-PIN MODULE DIMM  
SD-1**

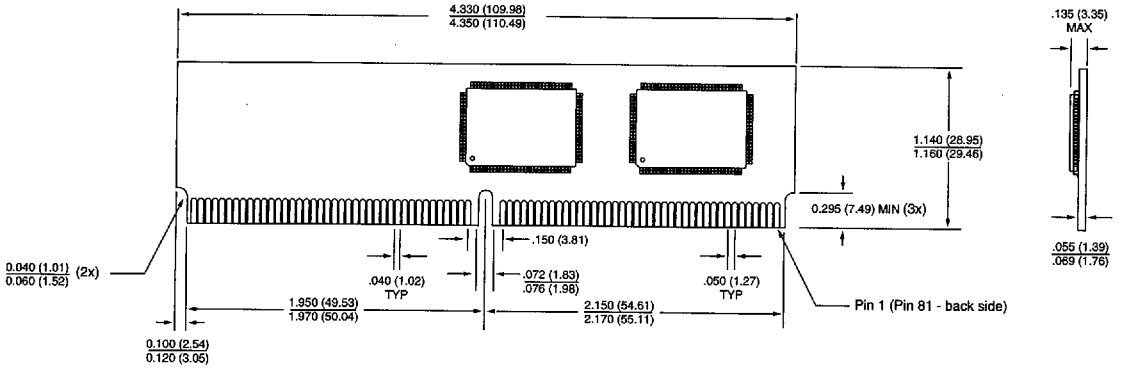

**160-PIN MODULE DIMM  
SD-2**

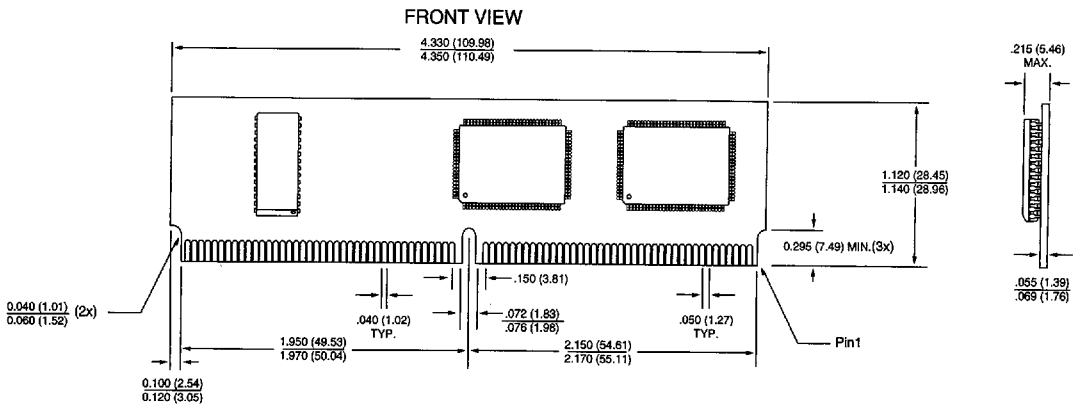

**NOTE:** 1. All dimensions in inches (millimeters)  $\frac{\text{MAX}}{\text{MIN}}$  or typical where noted.

**PACKAGE INFORMATION**

**160-PIN MODULE DIMM  
SD-3**

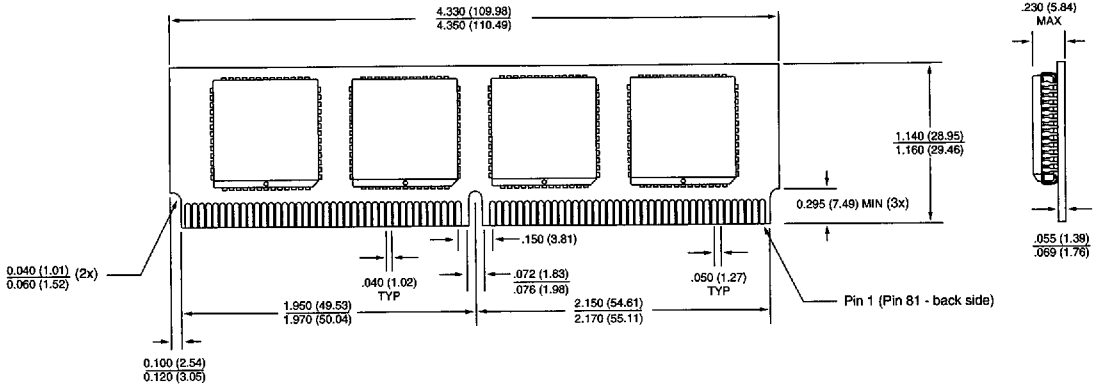

**160-PIN MODULE DIMM  
SD-4**

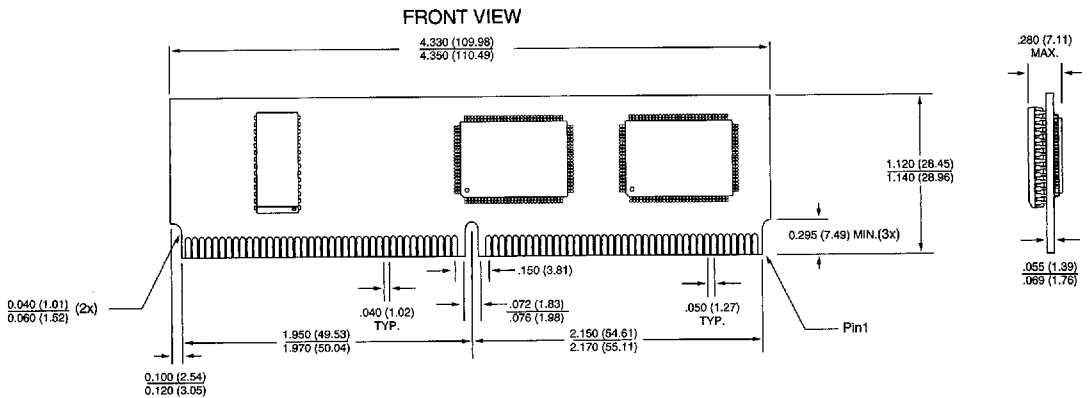

**NOTE:** 1. All dimensions in inches (millimeters)  $\frac{\text{MAX}}{\text{MIN}}$  or typical where noted.

**PACKAGE INFORMATION**