

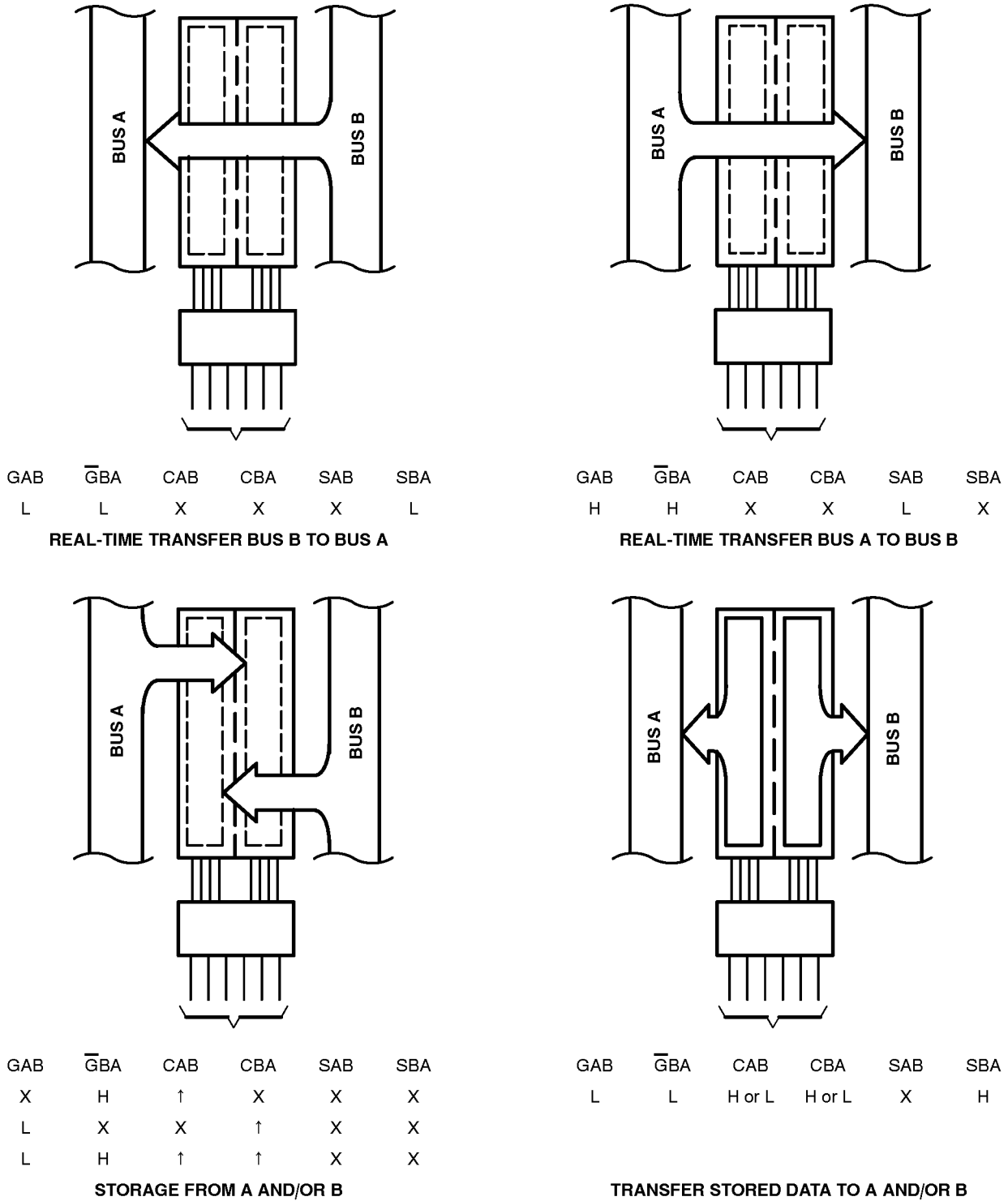

**74ACT11652**  
**OCTAL BUS TRANSCEIVER AND REGISTER**  
**WITH 3-STATE OUTPUTS**

SCAS087A – APRIL 1993 – REVISED APRIL 1996



**Figure 1. Bus Transfer Diagram**

**74ACT11652**  
**OCTAL BUS TRANSCEIVER AND REGISTER**  
**WITH 3-STATE OUTPUTS**

SCAS087A – APRIL 1993 – REVISED APRIL 1996

**FUNCTION TABLE**

INPUTS						DATA I/O†		OPERATION OR FUNCTION
GAB	$\overline{\text{GBA}}$	CAB	CBA	SAB	SBA	A1–A8	B1–B8	
L	H	H or L	H or L	X	X	Input	Input	Isolation
L	H	↑	↑	X	X	Input	Input	Store A and B data
X	H	↑	H or L	X	X	Input	Unspecified†	Store A, hold B
H	H	↑	↑	X‡	X	Input	Output	Store A in both registers
L	X	H or L	↑	X	X	Unspecified†	Input	Hold A, store B
L	L	↑	↑	X	X‡	Output	Input	Store B in both registers
L	L	X	X	X	L	Output	Input	Real-time B data to A bus
L	L	X	H or L	X	H	Output	Input	Stored B data to A bus
H	H	X	X	L	X	Input	Output	Real-time A data to B bus
H	H	H or L	X	H	X	Input	Output	Stored A data to B bus
H	L	H or L	H or L	H	H	Output	Output	Stored A data to B bus and stored B data to A bus

† The data-output functions may be enabled or disabled by various signals at the GAB or  $\overline{\text{GBA}}$  inputs. Data-input functions are always enabled, i.e., data at the bus terminals is stored on every low-to-high transition on the clock inputs.

‡ Select control = L: clocks can occur simultaneously. Select control = H: clocks must be staggered to load both registers.

**logic symbols§**

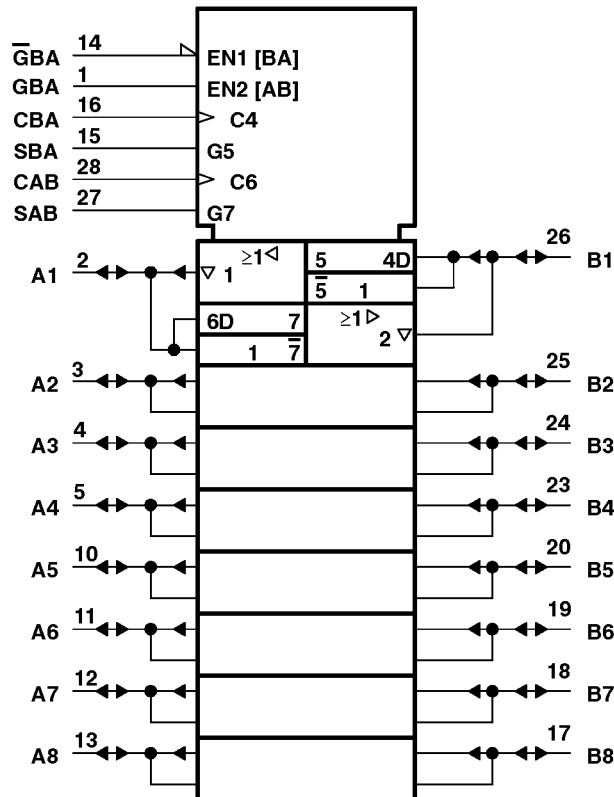

§ This symbol is in accordance with ANSI/IEEE Std 91-1984 and IEC Publication 617-12.

# 74ACT11652 OCTAL BUS TRANSCEIVER AND REGISTER WITH 3-STATE OUTPUTS

SCAS087A – APRIL 1993 – REVISED APRIL 1996

## logic diagram (positive logic)

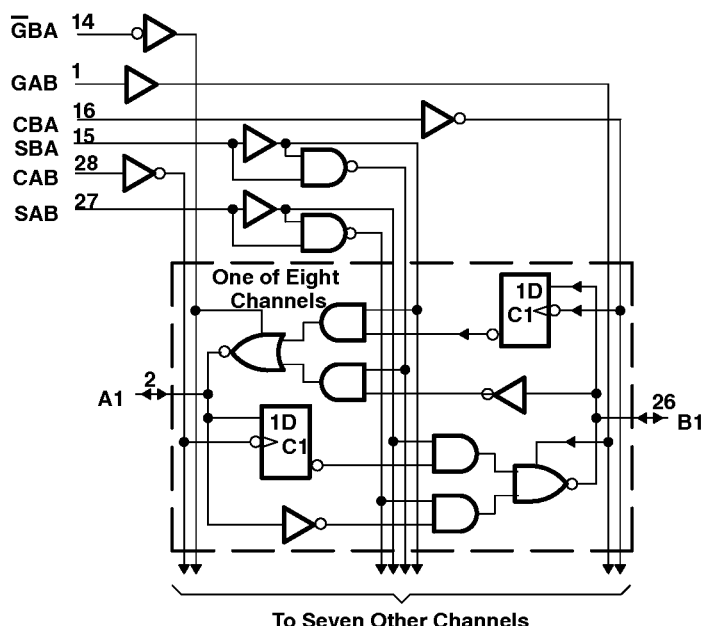

## absolute maximum rating over operating free-air temperature range (unless otherwise noted)†

Supply voltage, $V_{CC}$	.....	-0.5 V to 7 V
Input voltage range, $V_I$ (see Note 1)	.....	-0.5 V to $V_{CC} + 0.5$ V
Output voltage range, $V_O$ (see Note 1)	.....	-0.5 V to $V_{CC} + 0.5$ V
Input clamp current, $I_{IK}$ ( $V_I < 0$ or $V_I > V_{CC}$ )	.....	$\pm 20$ mA
Output clamp current, $I_{OK}$ ( $V_O < 0$ or $V_O > V_{CC}$ )	.....	$\pm 50$ mA
Continuous output current, $I_O$ ( $V_O = 0$ to $V_{CC}$ )	.....	$\pm 50$ mA
Continuous current through $V_{CC}$ or GND	.....	$\pm 200$ mA
Maximum power dissipation at $T_A = 55^\circ\text{C}$ (in still air) (see Note 2)	.....	1.7 W
Storage temperature range, $T_{stg}$	.....	$-65^\circ\text{C}$ to $150^\circ\text{C}$

† Stresses beyond those listed under "absolute maximum ratings" may cause permanent damage to the device. These are stress ratings only, and functional operation of the device at these or any other conditions beyond those indicated under "recommended operating conditions" is not implied. Exposure to absolute-maximum-rated conditions for extended periods may affect device reliability.

- NOTES: 1. The input and output voltage ratings may be exceeded if the input and output current ratings are observed.  
2. The maximum package power dissipation is calculated using a junction temperature of  $150^\circ\text{C}$  and a board trace length of 750 mils.

## recommended operating conditions (see Note 3)

		MIN	MAX	UNIT
$V_{CC}$	Supply voltage	4.5	5.5	V
$V_{IH}$	High-level input voltage	2		V
$V_{IL}$	Low-level input voltage		0.8	V
$V_I$	Input voltage	0	$V_{CC}$	V
$V_O$	Output voltage	0	$V_{CC}$	V
$I_{OH}$	High-level output current		-24	mA
$I_{OL}$	Low-level output current		24	mA
$\Delta t/\Delta V$	Input transition rise or fall rate	0	10	ns/V
$T_A$	Operating free-air temperature	-40	85	$^\circ\text{C}$

NOTE 3: Unused inputs must be held high or low to prevent them from floating.



POST OFFICE BOX 655303 • DALLAS, TEXAS 75265

**74ACT11652**  
**OCTAL BUS TRANSCEIVER AND REGISTER**  
**WITH 3-STATE OUTPUTS**

SCAS087A – APRIL 1993 – REVISED APRIL 1996

**electrical characteristics over recommended operating free-air temperature range (unless otherwise noted)**

PARAMETER		TEST CONDITIONS	V <sub>CC</sub>	T <sub>A</sub> = 25°C			MIN	MAX	UNIT
				MIN	TYP	MAX			
V <sub>OH</sub>		I <sub>OH</sub> = - 50 μA	4.5 V	4.4		4.4		V	
			5.5 V	5.4		5.4			
	I <sub>OH</sub> = - 24 mA	4.5 V	3.94		3.8				
		5.5 V	4.94		4.8				
		I <sub>OH</sub> = - 75 mA <sup>†</sup>	5.5 V			3.85			
V <sub>OL</sub>		I <sub>OL</sub> = 50 μA	4.5 V		0.1		0.1	V	
			5.5 V		0.1		0.1		
	I <sub>OL</sub> = 24 mA	4.5 V		0.36		0.44			
		5.5 V		0.36		0.44			
			I <sub>OL</sub> = 75 mA <sup>†</sup>	5.5 V			1.65		
I <sub>OZ</sub>	A or B ports <sup>‡</sup>	V <sub>O</sub> = V <sub>CC</sub> or GND	5.5 V		±0.5		±5	μA	
I <sub>I</sub>	GAB or $\overline{\text{G}}\text{BA}$	V <sub>I</sub> = V <sub>CC</sub> or GND	5.5 V		±0.1		±1	μA	
I <sub>CC</sub>		V <sub>I</sub> = V <sub>CC</sub> or GND, I <sub>O</sub> = 0	5.5 V		8		80	μA	
ΔI <sub>CC</sub> <sup>§</sup>		One input at 3.4 V, Other inputs at GND or V <sub>CC</sub>	5.5 V		0.9		1	mA	
C <sub>i</sub>	GAB or $\overline{\text{G}}\text{BA}$	V <sub>I</sub> = V <sub>CC</sub> or GND	5 V		4.5			pF	
C <sub>o</sub>	A or B ports	V <sub>O</sub> = V <sub>CC</sub> or GND	5 V		12			pF	

<sup>†</sup> Not more than one output should be tested at a time, and the duration of the test should not exceed 10 ms.

<sup>‡</sup> For I/O ports, the parameter I<sub>OZ</sub> includes the input leakage current.

<sup>§</sup> This is the increase in supply current for each input that is at one of the specified TTL voltage levels rather than 0 V or V<sub>CC</sub>.

**timing requirements over recommended ranges of supply voltage and operating free-air temperature (unless otherwise noted) (see Figure 2)**

PARAMETER		T <sub>A</sub> = 25°C		MIN	MAX	UNIT
		MIN	MAX			
f <sub>clock</sub>	Clock frequency	0	105	0	105	MHz
t <sub>w</sub>	Pulse duration, CAB or CBA high or low	4.8		4.8		ns
t <sub>su</sub>	Setup time, A before CLK <sup>↑</sup> or B before CBA <sup>↑</sup>	4		4		ns
t <sub>h</sub>	Hold time, A after CAB <sup>↑</sup> or B after CBA <sup>↑</sup>	2.5		2.5		ns



**74ACT11652**  
**OCTAL BUS TRANSCEIVER AND REGISTER**  
**WITH 3-STATE OUTPUTS**

SCAS087A – APRIL 1993 – REVISED APRIL 1996

**switching characteristics over recommended ranges of supply voltage and operating free-air temperature (unless otherwise noted) (see Figure 2)**

PARAMETER	FROM (INPUT)	TO (OUTPUT)	T <sub>A</sub> = 25°C			MIN	MAX	UNIT
			MIN	TYP	MAX			
f <sub>max</sub>			105			105		MHz
t <sub>PLH</sub>	A or B	B or A	3.8	7	9.9	3.8	11.1	ns
t <sub>PHL</sub>			3.4	6.7	10.7	3.4	11.6	
t <sub>PLH</sub>	CBA or CAB	A or B	5.4	8.4	11.8	5.4	13.1	ns
t <sub>PHL</sub>			6.1	9.4	13.1	6.1	14.4	
t <sub>PLH</sub>	SBA or SAB† with A or B high	A or B	2.8	6.2	10.1	2.8	11	ns
t <sub>PHL</sub>			5.5	8.7	12.1	5.5	13.3	
t <sub>PLH</sub>	SBA or SAB† with A or B low	A or B	4.9	7.8	11	4.9	12.2	ns
t <sub>PHL</sub>			3.9	7.5	11.6	3.9	12.6	
t <sub>PZH</sub>	$\overline{\text{G}}\text{BA}$	A	3.3	7.2	11.4	3.3	12.6	ns
t <sub>PZL</sub>			4.1	7.8	12.6	4.1	13.8	
t <sub>PHZ</sub>	$\overline{\text{G}}\text{BA}$	A	5.2	7.2	9.3	5.2	9.9	ns
t <sub>PLZ</sub>			4.8	6.7	8.6	4.8	9.3	
t <sub>PZH</sub>	GAB	B	5.1	9.1	13.4	5.1	15.2	ns
t <sub>PZL</sub>			5.8	9.7	14.2	5.8	16.1	
t <sub>PHZ</sub>	GAB	B	3.4	6.8	9.7	3.4	10.3	ns
t <sub>PLZ</sub>			3.1	6	8.8	3.1	9.3	

† These parameters are measured with the internal output state of the storage register opposite that of the bus input.

**operating characteristics, V<sub>CC</sub> = 5 V, T<sub>A</sub> = 25°C**

PARAMETER		TEST CONDITIONS	TYP	UNIT
C <sub>pd</sub>	Power dissipation capacitance per transceiver	C <sub>L</sub> = 50 pF, f = 1 MHz	59	pF
			14	



