

**DESCRIPTION**

The HY62QF8100 is a high speed, low power and 1M bit full CMOS SRAM organized as 131,072 words by 8bit. The HY62QF8100 uses high performance full CMOS process technology and designed for high speed low power circuit technology. It is particularly well suited for used in high density low power system application. This device has a data retention mode that guarantees data to remain valid at a minimum power supply voltage of 1.5V.

**FEATURES**

- Fully static operation and Tri-state output
- TTL compatible inputs and outputs
- Battery backup(LL/SL-part)
  - . 1.5V(min) data retention
- Standard pin configuration
  - . 32 - sTSOP1 - 8X13.4(Standard)

Product No.	Voltage (V)	Speed (ns)	Operation Current/Icc(mA)	Standby Current(uA)		Temperature (°C)
				LL	SL	
HY62QF8100	2.3~2.7	85/100/120	5	5	1	0~70
HY62QF8100-I	2.3~2.7	85/100/120	5	5	1	-40~85(I)

Note 1. Blank : Commercial, I : Industrial  
 2. Current value is max.

**PIN CONNECTION ( Top View )**

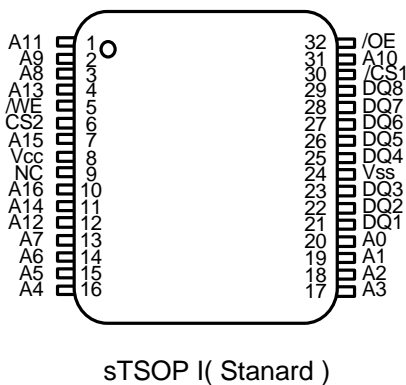

**BLOCK DIAGRAM**

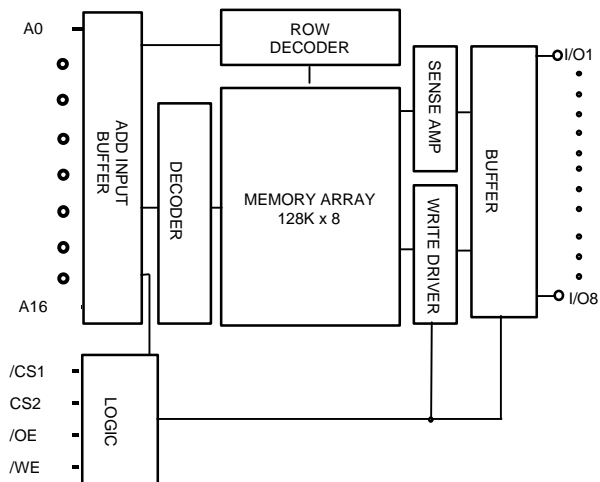

**PIN DESCRIPTION**

Pin Name	Pin Function	Pin Name	Pin Function
/CS1	Chip Select 1	A0 ~ A16	Address Inputs
CS2	Chip Select 2	I/O1 ~ I/O8	Data Inputs / Outputs
/WE	Write Enable	Vcc	Power( 2.3V~2.7V )
/OE	Output Enable	Vss	Ground

**ORDERING INFORMATION**

Part No.	Speed	Power	Temp.	Package
HY62QF8100LLST	85/100/120	LL-part		sTSOP I (Standard)
HY62QF8100SLST	85/100/120	SL-part		sTSOP I (Standard)
HY62QF8100LLST-I	85/100/120	LL-part	I	sTSOP I (Standard)
HY62QF8100SLST-I	85/100/120	SL-part	I	sTSOP I (Standard)

Note 1. Blank : Commercial, I : Industrial

**ABSOLUTE MAXIMUM RATING (1)**

Symbol	Parameter	Rating	Unit	Remark
V <sub>IN</sub> , V <sub>OUT</sub>	Input/Output Voltage	-0.2 to 3.6	V	
V <sub>CC</sub>	Power Supply	-0.2 to 4.6	V	
T <sub>A</sub>	Operating Temperature	0 to 70	°C	HY62QF8100
		-40 to 85	°C	HY62QF8100-I
T <sub>STG</sub>	Storage Temperature	-55 to 150	°C	
P <sub>D</sub>	Power Dissipation	1.0	W	
T <sub>SOLDER</sub>	Ball Soldering Temperature & Time	260 • 10	°C • sec	

Note

- Stresses greater than those listed under ABSOLUTE MAXIMUM RATINGS may cause permanent damage to the device. This is stress rating only and the functional operation of the device under these or any other conditions above those indicated in the operation of this specification is not implied. Exposure to the absolute maximum rating conditions for extended period may affect reliability.

**TRUTH TABLE**

/CS1	CS2	/WE	/OE	Mode	I/O	Power
H	X	X	X	Deselected	High-Z	Standby
X	L	X	X	Deselected	High-Z	Standby
L	H	H	H	Output Disabled	High-Z	Active
L	H	H	L	Read	Data Out	Active
L	H	L	X	Write	Data In	Active

Note:

- H=V<sub>IH</sub>, L=V<sub>IL</sub>, X=don't care(V<sub>IH</sub> or V<sub>IL</sub>)

**RECOMMENDED DC OPERATING CONDITION**

Symbol	Parameter	Min.	Typ.	Max.	Unit
V <sub>CC</sub>	Supply Voltage	2.3	2.5	2.7	V
V <sub>SS</sub>	Ground	0	0	0	V
V <sub>IH</sub>	Input High Voltage	2.0	-	V <sub>CC</sub> +0.3	V
V <sub>IL</sub>	Input Low Voltage	-0.3(1)	-	0.4	V

Note : 1. V<sub>IL</sub> = -1.5V for pulse width less than 30ns  
 2. Undershoots are sampled and not 100% tested.

**DC ELECTRICAL CHARACTERISTICS**

V<sub>CC</sub> = 2.3V~2.7V, T<sub>A</sub> = 0°C to 70°C / -40°C to 85°C (I)

Sym	Parameter	Test Condition	Min.	Typ.	Max.	Unit	
I <sub>LI</sub>	Input Leakage Current	V <sub>s</sub> ≤ V <sub>IN</sub> ≤ V <sub>CC</sub>	-1	-	1	uA	
I <sub>LO</sub>	Output Leakage Current	V <sub>SS</sub> ≤ V <sub>OUT</sub> ≤ V <sub>CC</sub> , /CS1 = V <sub>IH</sub> or /OE = V <sub>IH</sub> or /WE = V <sub>I</sub>	-1	-	1	uA	
I <sub>CC</sub>	Operating Power Supply Current	/CS1 = V <sub>IL</sub> , V <sub>IN</sub> = V <sub>IH</sub> or V <sub>IL</sub> , I <sub>I/O</sub> = 0mA	-	-	5	mA	
I <sub>CC1</sub>	Average Operating Current	/CS1 = V <sub>IL</sub> , Min Duty Cycle = 100% I <sub>I/O</sub> = 0mA, V <sub>IN</sub> = V <sub>IH</sub> or V <sub>IL</sub>	-	-	40	mA	
I <sub>SB</sub>	TTL Standby Current (TTL Input)	/CS1 = V <sub>IH</sub>	-	-	0.3	mA	
I <sub>SB1</sub>	Standby Current (CMOS Input)	/CS1 ≥ V <sub>CC</sub> - 0.2V	SL	-	-	1	uA
			LL	-	1	5	uA
V <sub>OL</sub>	Output Low Voltage	I <sub>OL</sub> = 0.5mA	-	-	0.4	V	
V <sub>OH</sub>	Output High Voltage	I <sub>OH</sub> = -0.5mA	2.0	-	-	V	

Note : 1. Typical values are at V<sub>CC</sub> = 2.5V, T<sub>A</sub> = 25°C.  
 2. Typical values are sampled and not 100% tested.

**CAPACITANCE**

(Temp = 25°C, f = 1.0MHz)

Symbol	Parameter	Condition	Max.	Unit
C <sub>IN</sub>	Input Capacitance(Add, /CS1, /WE, /OE)	V <sub>IN</sub> = 0V	8	pF
C <sub>OUT</sub>	Output Capacitance(I/O)	V <sub>I/O</sub> = 0V	10	pF

Note : These parameters are sampled and not 100% tested

### AC CHARACTERISTICS

V<sub>CC</sub>=2.3V~2.7V, T<sub>A</sub> = 0°C to 70°C / -40°C to 85°C(I), unless otherwise specified

#	Symbol	Parameter	-85		-10		-12		Unit
			Min.	Max.	Min.	Max.	Min	Max.	
READ CYCLE									
1	t <sub>RC</sub>	Read Cycle Time	85	-	100	-	120	-	ns
2	t <sub>AA</sub>	Address Access Time	-	85	-	100	-	120	ns
3	t <sub>ACS</sub>	Chip Select Access Time	-	85	-	100	-	120	ns
4	t <sub>OE</sub>	Output Enable to Output Valid	-	45	-	50	-	60	ns
5	t <sub>CLZ</sub>	Chip Select to Output in Low Z	10	-	20	-	20	-	ns
6	t <sub>OLZ</sub>	Output Enable to Output in Low Z	5	-	5	-	10	-	ns
7	t <sub>CHZ</sub>	Chip Deselection to Output in High Z	0	30	0	30	0	40	ns
8	t <sub>OHZ</sub>	Out Disable to Output in High Z	0	30	0	30	0	40	ns
9	t <sub>OH</sub>	Output Hold from Address Change	10	-	15	-	15	-	ns
WRITE CYCLE									
10	t <sub>WC</sub>	Write Cycle Time	85	-	100	-	120	-	ns
11	t <sub>CW</sub>	Chip Selection to End of Write	70	-	80	-	100	-	ns
12	t <sub>AW</sub>	Address Valid to End of Write	70	-	80	-	100	-	ns
13	t <sub>AS</sub>	Address Set-up Time	0	-	0	-	0	-	ns
14	t <sub>WP</sub>	Write Pulse Width	55	-	75	-	85	-	ns
15	t <sub>WR</sub>	Write Recovery Time	0	-	0	-	0	-	ns
16	t <sub>WHZ</sub>	Write to Output in High Z	0	30	0	35	0	40	ns
17	t <sub>DW</sub>	Data to Write Time Overlap	35	-	45	-	50	-	ns
18	t <sub>DH</sub>	Data Hold from Write Time	0	-	0	-	0	-	ns
19	t <sub>OW</sub>	Output Active from End of Write	5	-	10	-	10	-	ns

### AC TEST CONDITIONS

T<sub>A</sub> = 0°C to 70°C / -40°C to 85°C (I), unless otherwise specified

Parameter	Value
Input Pulse Level	0.4V to 2.2V
Input Rise and Fall Time	5ns
Input and Output Timing Reference Level	1.1V
Output Load	CL = 30pF + 1TTL Load

### AC TEST LOADS

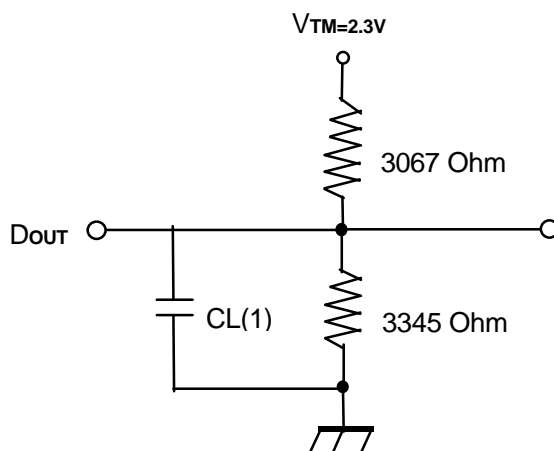

Note

1. Including jig and scope capacitance

**TIMING DIAGRAM**

READ CYCLE 1(Note 1,4)

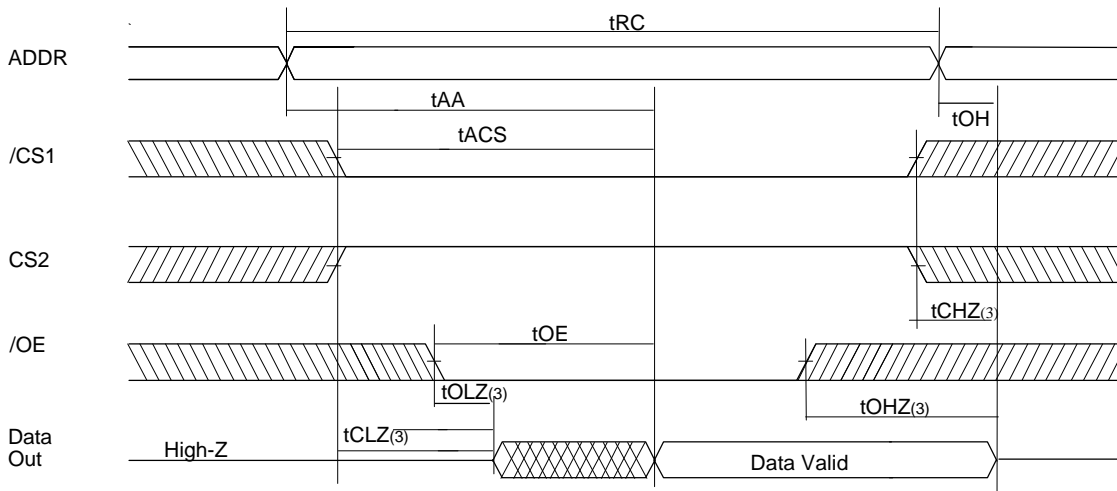

READ CYCLE 2(Note 1,2,4)

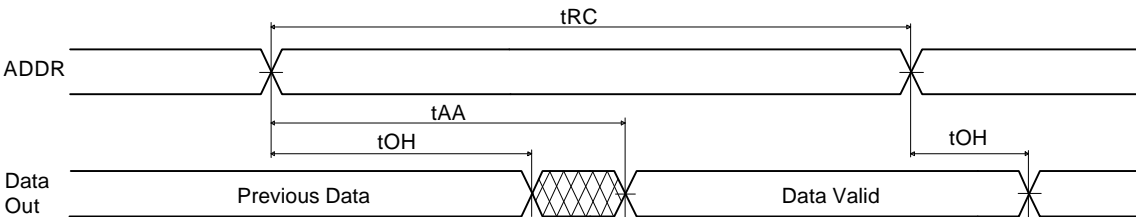

READ CYCLE 3(Note 1,2,4)

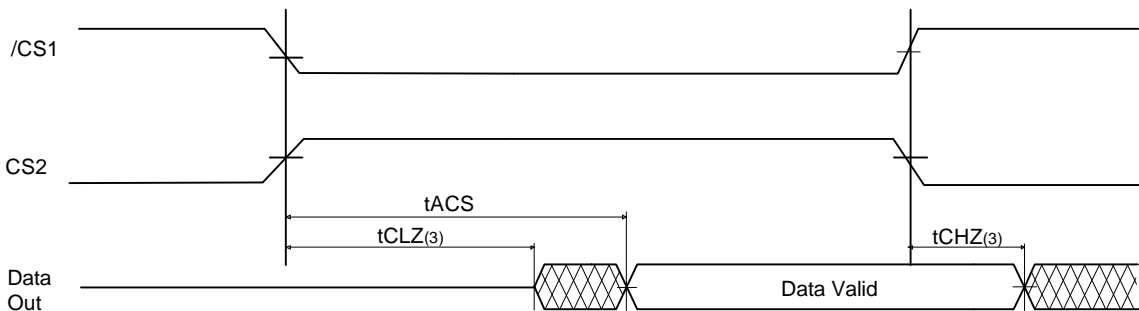

Notes:

1. Read Cycle occurs whenever a high on the /WE and /OE is low /CS1 and CS2 are in active status.
2. /OE = V<sub>IL</sub>
3. Transition is measured ± 200mV from steady state voltage.  
This parameter is sampled and not 100% tested.
4. /CS1 in high for the standby, low for active  
CS2 in low for the standby, high for active

**WRITE CYCLE 1(1,4,5,9) (/WE Controlled)**

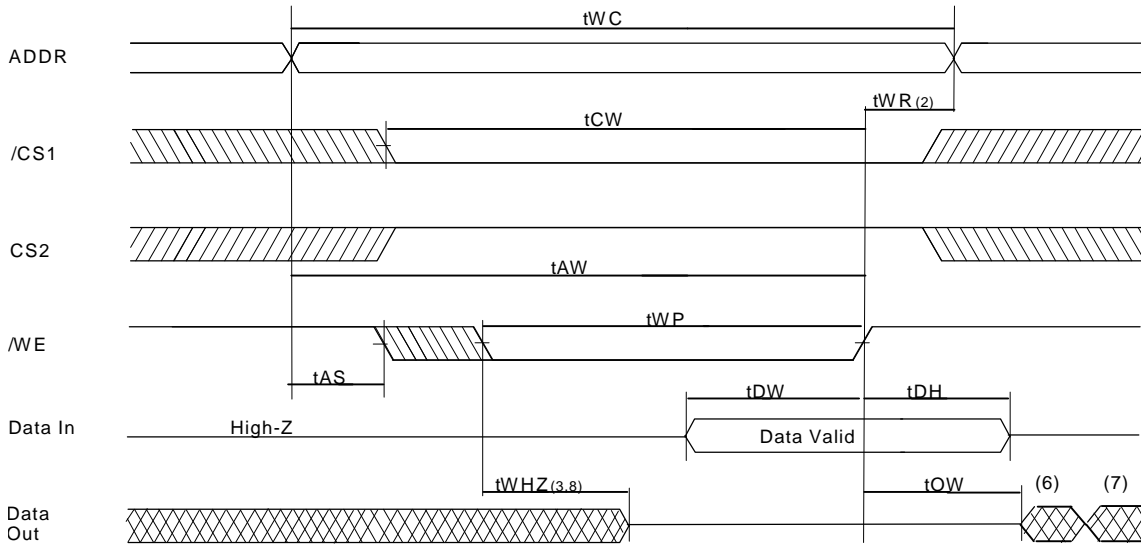

**WRITE CYCLE 2 (Note 1,4,5,9) (/CS1, CS2 Controlled)**

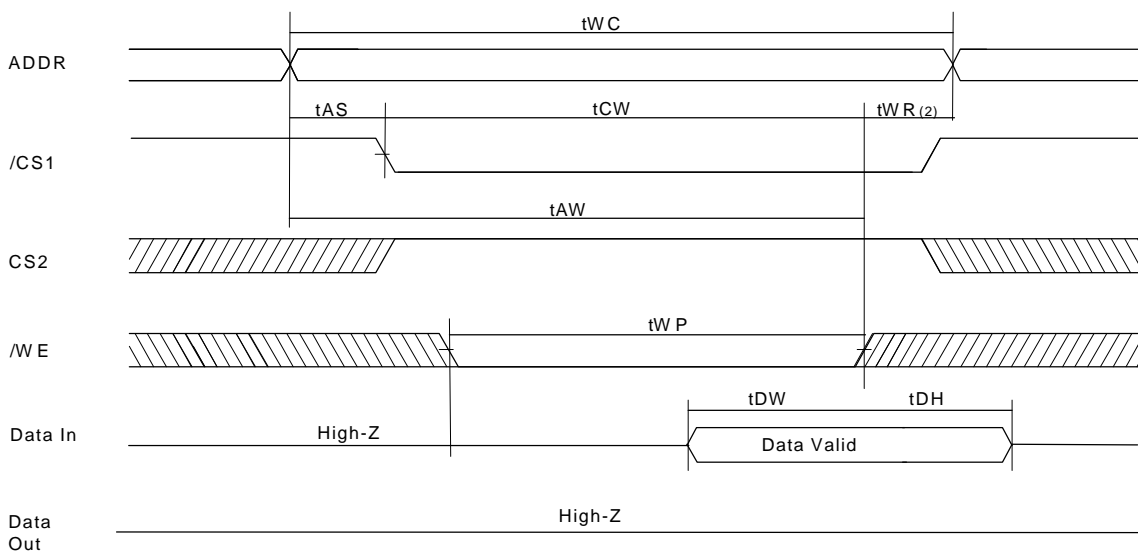

**Notes:**

1. A write occurs whenever a low on the /WE and /OE is low /CS1 and CS2 are in active state.
2.  $t_{WR}$  is measured from the earlier of /CS1 or /WE going high or CS2 going low to the end of write cycle.
3. During this period, I/O pins are in the output state so that the input signals of opposite phase to the output must not be applied.
4. If the the /CS1 low transition and CS2 high transition occur simultaneously with the /WE low transition or after the /WE transition, outputs remain in a high impedance state.
5. /OE is continuously low(/OE= $V_{IL}$ )
6. Q(data out) is the same phase with the write data of this write cycle.
7. Q(data out) is the read data of the next address.
8. Transition is measured  $\pm 200mV$  from steady state.  
This parameter is sampled and not 100% tested.
9. /CS1 in high for the standby, low for active  
CS2 in low for the standby, high for active

**DATA RETENTION ELECTRIC CHARACTERISTIC**

TA = 0°C to 70°C / -40°C to 85°C (I)

Symbol	Parameter	Test Condition	Min	Typ	Max	Unit	
VDR	Vcc for Data Retention	/CS1 ≥ Vcc - 0.2V, CS2 ≤ 0.2V or ≥ Vcc - 0.2V Vss ≤ VIN ≤ Vcc	1.5	-	2.7	V	
ICCDR	Data Retention Current	Vcc = 2.0V, /CS1 ≥ Vcc - 0.2V, CS2 ≤ 0.2V or ≥ Vcc - 0.2V Vss ≤ VIN ≤ Vcc	LL	-	-	5	uA
			SL			1	uA
tCDR	Chip Deselect to Data Retention Time	See Data Retention Timing Diagram	0	-	-	ns	
tR	Operating Recovery Time		tRC(2)	-	-	ns	

Notes:

1. Typical values are under the condition of TA = 25°C.
2. tRC is read cycle time.

**DATA RETENTION TIMING DIAGRAM 1**

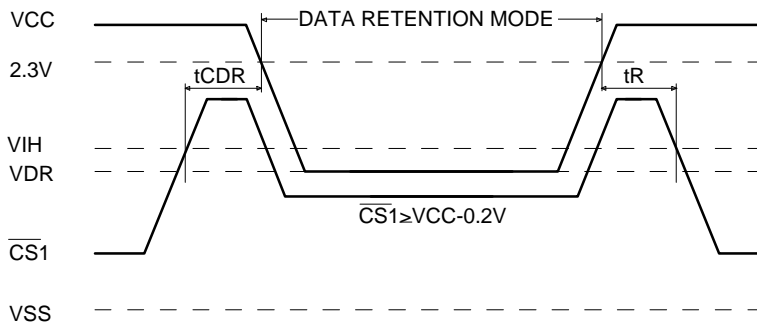

**DATA RETENTION TIMING DIAGRAM 2**

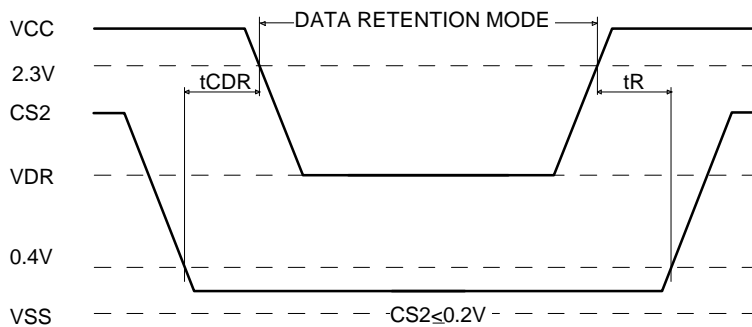

**PACKAGE INFORMATION**

32pin 8x13.4mm Smaller Thin Small Outline Package Standard(ST)

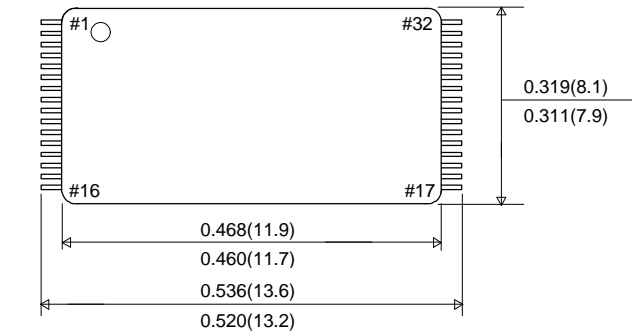

UNIT : INCH(mm)

