

# Am2918

Quad D Register with Standard and Three-State Outputs

## DISTINCTIVE CHARACTERISTICS

- Advanced Schottky technology
- Four D-type flip-flops
- Four standard totem-pole outputs
- Four three-state outputs
- 75 MHz clock frequency

## GENERAL DESCRIPTION

New Schottky circuits such as the Am2918 register provide the design engineer with additional flexibility in system configuration – especially with regard to bus structure, organization and speed. The Am2918 is a quadruple D-type register with four standard totem-pole outputs and four three-state bus-type outputs. The 16-pin device also features a buffered common clock (CP) and a buffered common output control ( $\overline{OE}$ ) for the Y outputs. Information meeting the set-up and hold requirements on the D inputs is transferred to the Q outputs on the LOW-to-HIGH transition of the clock.

The same data as on the Q outputs is enabled at the three-state Y outputs when the "output control" ( $\overline{OE}$ ) input is

LOW. When the  $\overline{OE}$  input is HIGH, the Y outputs are in the high-impedance state.

The Am2918 register can be used in bipolar microprocessor designs as an address register, status register, instruction register or for various data or microword register applications. Because of the unique design of the three-state output, the device features very short propagation delay from the clock to the Q or Y outputs. Thus, system performance and architectural design can be improved by using the Am2918 register. Other applications of Am2918 register can be found in microprogrammed display systems, communication systems and most general or special purpose digital signal processing equipment.

## BLOCK DIAGRAM

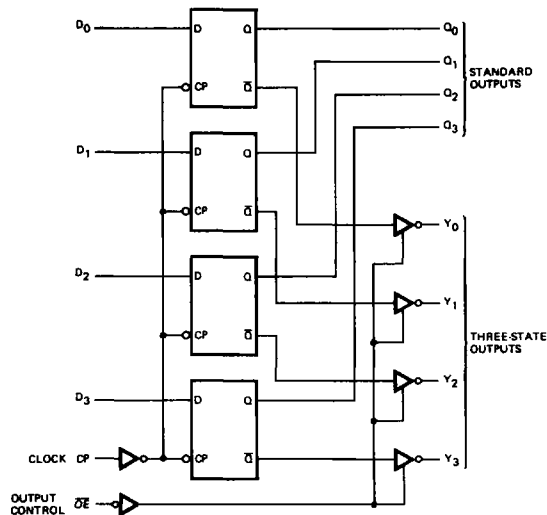

BD002150

## RELATED PRODUCTS

Part No.	Description
Am29LS18	Low Power Version
Am2919	Quad Register

### CONNECTION DIAGRAM Top View

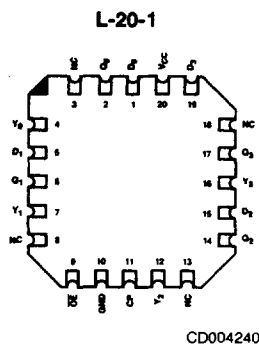
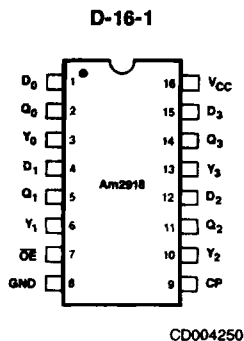

Note: Pin 1 is marked for orientation

### LOGIC SYMBOL

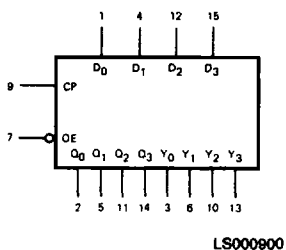

### METALLIZATION AND PAD LAYOUT

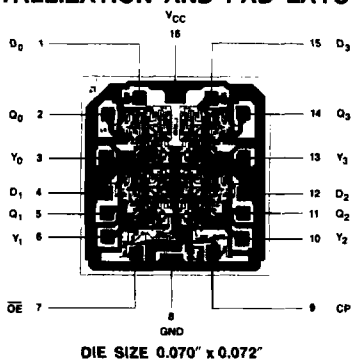

5

### ORDERING INFORMATION

AMD products are available in several packages and operating ranges. The order number is formed by a combination of the following: Device number, speed option (if applicable), package type, operating range and screening option (if desired).

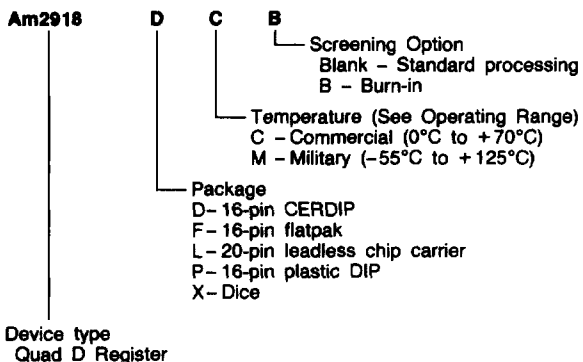

Valid Combinations	
Am2918	PC DC, DCB, DM, DMB FM, FMB LC, LCB, LM, LMB XC, XM

#### Valid Combinations

Consult the AMD sales office in your area to determine if a device is currently available in the combination you wish.

## PIN DESCRIPTION

Pin No.	Name	I/O	Description
	D <sub>i</sub>	I	The four data inputs to the register.
	Q <sub>i</sub>	O	The four data outputs of the register with standard totem-pole active pull-up outputs. Data is passed non-inverted.
	Y <sub>i</sub>	O	The four three-state data outputs of the register. When the three-state outputs are enabled, data is passed non-inverted. A HIGH on the "output control" input forces the Y <sub>i</sub> outputs to the high-impedance state.
9	CP		CP Clock. The buffered common clock for the register. Enters data on the LOW-to-HIGH transition.
7	$\overline{OE}$		$\overline{OE}$ Output Control. When the $\overline{OE}$ input is HIGH, the Y <sub>i</sub> outputs are in the high-impedance state. When the $\overline{OE}$ input is LOW, the TRUE register data is present at the Y <sub>i</sub> outputs.

## TRUTH TABLE

INPUTS			OUTPUTS		NOTES
$\overline{OE}$	CLOCK CP	D	Q	Y	
H	L	X	NC	Z	-
H	H	X	NC	Z	-
H	↑	L	L	Z	-
H	↑	H	H	Z	-
L	↑	L	L	L	-
L	↑	H	H	H	-
L	-	-	L	L	1
L	-	-	H	H	1

L = LOW                      NC = No change  
 H = HIGH                     ↑ = LOW to HIGH transition  
 X = Don't care              Z = High Impedance

Note: 1. When  $\overline{OE}$  is LOW, the Y output will be in the same logic state as the Q output.

## APPLICATIONS

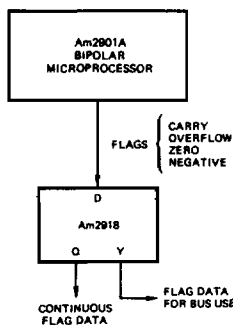

The Am2918 as a 4-bit status register

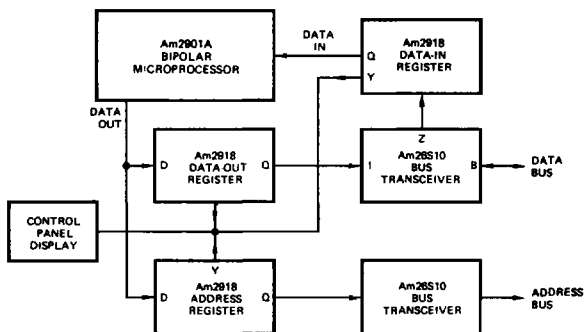

AF001660

The Am2918 used as data-in, data-out and address registers.

5

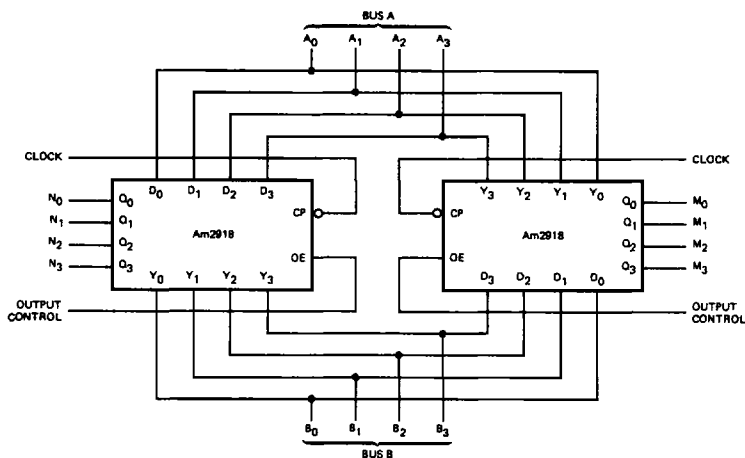

AF001580

The Am2918 can be connected for bi-directional interface between two buses. The device on the left stores data from the A-bus and drives the A-bus. The device on the right stores data from the B-bus and drives the A-bus. The output control is used to place either or both drivers in the high-impedance state. The contents of each register are available for continuous usage at the N and M ports of the device.

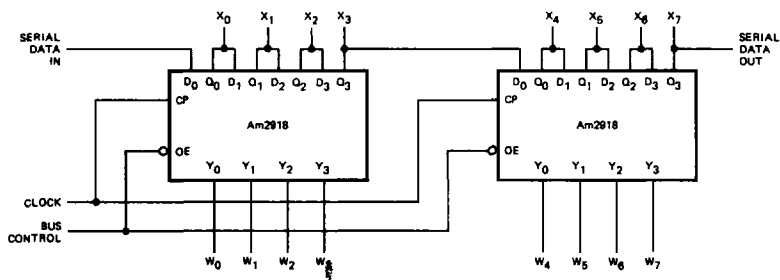

AF001650

8-Bit serial to parallel converter with three-state output (W) and direct access to the register word (X).

**ABSOLUTE MAXIMUM RATINGS**

Storage Temperature ..... -65°C to +150°C  
 (Ambient) Temperature Under Bias ..... -55°C to +125°C  
 Supply Voltage to Ground Potential  
 (Pin 16 to Pin 8) Continuous ..... -0.5V to +7.0V  
 DC Voltage Applied to Outputs For  
 High Output State ..... -0.5V to +V<sub>CC</sub> max  
 DC Input Voltage ..... -0.5V to +5.5V  
 DC Output Current, Into Outputs ..... 30mA  
 DC Input Current ..... -30mA to +5.0mA

*Stresses above those listed under ABSOLUTE MAXIMUM RATINGS may cause permanent device failure. Functionality at or above these limits is not implied. Exposure to absolute maximum ratings for extended periods may affect device reliability.*

**OPERATING RANGES**

Commercial (C) Devices

Temperature ..... 0°C to +70°C  
 Supply Voltage ..... +4.75V to +5.25V

Military (M) Devices

Temperature ..... -55°C to +125°C  
 Supply Voltage ..... +4.5V to +5.5V

*Operating ranges define those limits over which the functionality of the device is guaranteed.*

**DC CHARACTERISTICS** over operating range unless otherwise specified

Parameters	Description	Test Conditions (Note 2)	Min	Typ (Note 1)	Max	Units	
V <sub>OH</sub>	Output HIGH Voltage	V <sub>CC</sub> = MIN, V <sub>IN</sub> = V <sub>IH</sub> or V <sub>IL</sub>	Q I <sub>OH</sub> = -1mA	MIL	2.5	3.4	Volts
				COM'L	2.7	3.4	
			Y	XM, I <sub>OH</sub> = -2mA	2.4	3.4	
				XC, I <sub>OH</sub> = -6.5mA	2.4	3.4	
V <sub>OL</sub>	Output LOW Voltage (Note 6)	V <sub>CC</sub> = MIN, I <sub>OL</sub> = 20mA V <sub>IN</sub> = V <sub>IH</sub> or V <sub>IL</sub>			0.5	Volts	
V <sub>IH</sub>	Input HIGH Level	Guaranteed input logical HIGH voltage for all inputs	2.0			Volts	
V <sub>IL</sub>	Input LOW Level	Guaranteed input logical LOW voltage for all inputs			0.8	Volts	
V <sub>I</sub>	Input Clamp Voltage	V <sub>CC</sub> = MIN, I <sub>IN</sub> = -18mA			-1.2	Volts	
I <sub>IL</sub> (Note 3)	Input LOW Current	V <sub>CC</sub> = MAX, V <sub>IN</sub> = 0.5V			-2.0	mA	
I <sub>IH</sub> (Note 3)	Input HIGH Current	V <sub>CC</sub> = MAX, V <sub>IN</sub> = 2.7V			50	μA	
I <sub>I</sub>	Input HIGH Current	V <sub>CC</sub> = MAX, V <sub>IN</sub> = 5.5V			1.0	mA	
I <sub>O</sub>	Y Output Off-State Leakage Current	V <sub>CC</sub> = MAX	V <sub>O</sub> = 2.4V		50	μA	
			V <sub>O</sub> = 0.4V		-50		
I <sub>SC</sub>	Output Short Circuit Current (Note 4)	V <sub>CC</sub> = MAX	-40		-100	mA	
I <sub>CC</sub>	Power Supply Current	V <sub>CC</sub> = MAX (Note 5)		80	130	mA	

- Notes: 1. Typical limits are at V<sub>CC</sub> = 5.0V, T<sub>A</sub> = 25°C ambient and maximum loading.  
 2. For conditions shown as MIN or MAX, use the appropriate value specified under Operating Ranges for the applicable device type.  
 3. Actual input currents = Unit Load Current x Input Load Factor (see Loading Rules).  
 4. Not more than one output should be shorted at a time. Duration of the short circuit test should not exceed one second.  
 5. I<sub>CC</sub> is measured with all inputs at 4.5V and all outputs open.  
 6. Measured on Q outputs with Y outputs open. Measured on Y outputs with Q outputs open.

**SCHOTTKY INPUT/OUTPUT CURRENT INTERFACE CONDITIONS**

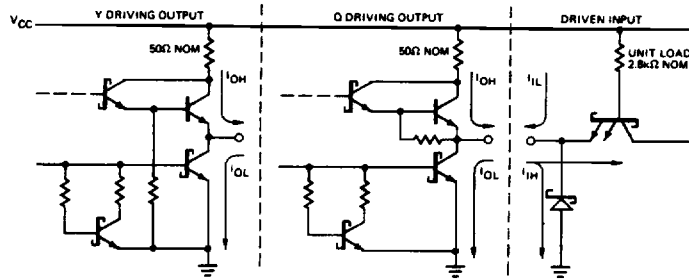

IC000410

Note: Actual current flow direction shown.

**SWITCHING CHARACTERISTICS** ( $T_A = +25^\circ\text{C}$ ,  $V_{CC} = 5.0\text{V}$ ,  $R_L = 280\Omega$ )

5

Parameters	Description	Test Conditions	Min	Typ	Max	Units	
$t_{PLH}$	Clock to Q Output	$C_L = 15\text{ pF}$		6.0	9.0	ns	
$t_{PHL}$				8.5	13		
$t_{pw}$	Clock Pulse Width		HIGH	7.0		ns	
			LOW	9.0			
$t_s$	Data			5.0		ns	
$t_h$	Data			3.0		ns	
$t_{PLH}$	Clock to Y Output (OE LOW)				6.0	9.0	ns
$t_{PHL}$					8.5	13	
$t_{ZH}$	Output Control to Output		$C_L = 15\text{ pF}$		12.5	19	ns
$t_{ZL}$					12	18	
$t_{HZ}$		$C_L = 5.0\text{ pF}$		4.0	6.0		
$t_{LZ}$				7.0	10.5		
$f_{max}$	Maximum Clock Frequency	$C_L = 15\text{ pF}$	75	100		MHz	