

SANKEN

SANKEN
LIGHT EMITTING DIODES

T-1 Contact Mount Standard Type (Non-Diffused)

SEL 3110 S

SEL 3710 K

FEATURES

- Thermal Capability by Thick Collar
- Low Profile
- High Reliability/Long Life under Contact Mounting Use
- Selection of 2 Colors/Intensities
- Pulse-Drivable
- CMOS/MOS, TTL Compatible

APPLICATIONS

- Car Audio Set, Telephone Set
- General Use
- Communication Devices

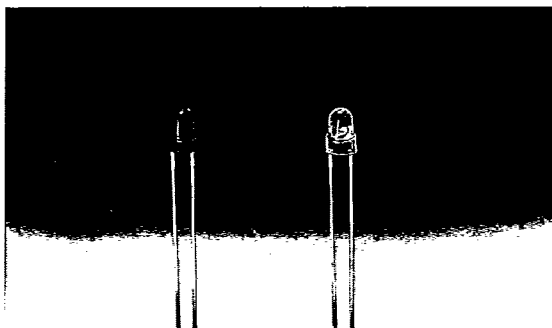

Package Dimensions

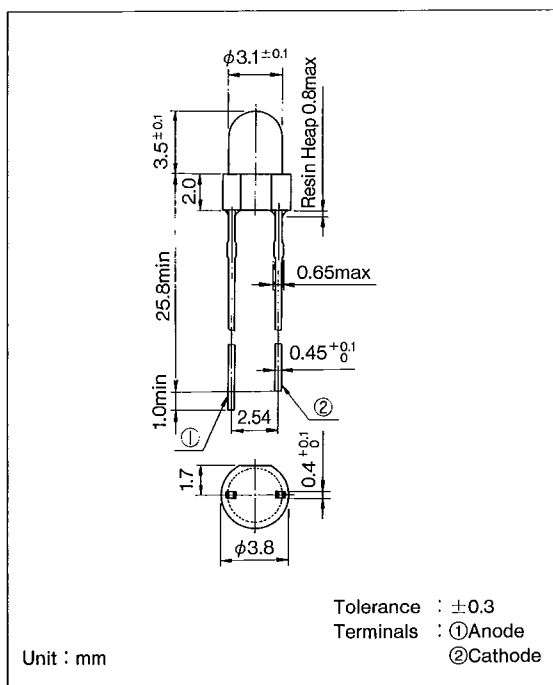

Intensity Ranks

Type No.	Intensity Min. (mcd)	Condition I _F (mA)	Color		
			Lens	Chip	
SEL 3110 S A	2.0	10	R	R	
	B				2.6
	C				3.4
	D				4.4
SEL 3710 K A	10.0	10	Y	Y	
	B				13.6
	C				18.4
	D				24.4

R=Red Y=Yellow

Electro-Optical Characteristics (Ta = 25°C)

Symbol	Description	Type No.	Min.	Typ.	Max.	Unit	Test Condition
I_v	Intensity	SEL 3110 S SEL 3710 K	2.0 10.0	4.4 24.4		mcd	$I_F=10$ (mA)
$2\theta_{1/2}$	Including Angle Between Half Intensity Points	SEL 3110 S SEL 3710 K		40°		Deg	$I_F=10$ (mA) See Note 1
λ_p	Peak Wavelength	SEL 3110 S SEL 3710 K		700 570		nm	$I_F=10$ (mA)
$\Delta\lambda$	Spectral Line Halfwidth	SEL 3110 S SEL 3710 K		100 40		nm	
λ_d	Dominant Wavelength	SEL 3110 S SEL 3710 K		650 566			
C	Capacitance	SEL 3110 S SEL 3710 K		38 15		pF	$V_F=0$ $f=1$ (MHz)
V_F	DC Forward Voltage	SEL 3110 S SEL 3710 K	1.5	2.0	3.0	V	$I_F=10$ (mA)
V_R	DC Reverse Voltage	SEL 3110 S SEL 3710 K	5.0			V	$I_R=100$ (μ A)

- Notes : 1. $\theta_{1/2}$ is the off-axis angle at which the intensity is half the axial intensity.
 2. The dominant wavelength, λ_d , is derived from the CIE chromaticity diagram and it represents the single wavelength which defines the color of the device.

Absolute Maximum Ratings (Ta = 25°C)

Symbol	Description	Ratings	Unit
I _P	Peak Forward Current* ¹	100	mA
I _F	Max. DC Forward Current* ²	30	mA
V _R	DC Reverse Voltage (I _R = 100μA)	5	V
I _{FP}	Transient Max. Peak Forward Current* ³ (10μsec Pulse)	500	mA
T _{op}	Operating Temp. Range	-55 to +100	°C
T _{stg}	Storage Temp. Range	-55 to +100	
T _{slid}	Lead Soldering Temp. (more than 1.6 mm from body)	260°C for 5 seconds	

- Notes : 1. See Figure 4
 2. This current derates linearly from 25°C at 0.33 mA/°C
 3. Only for one pulse

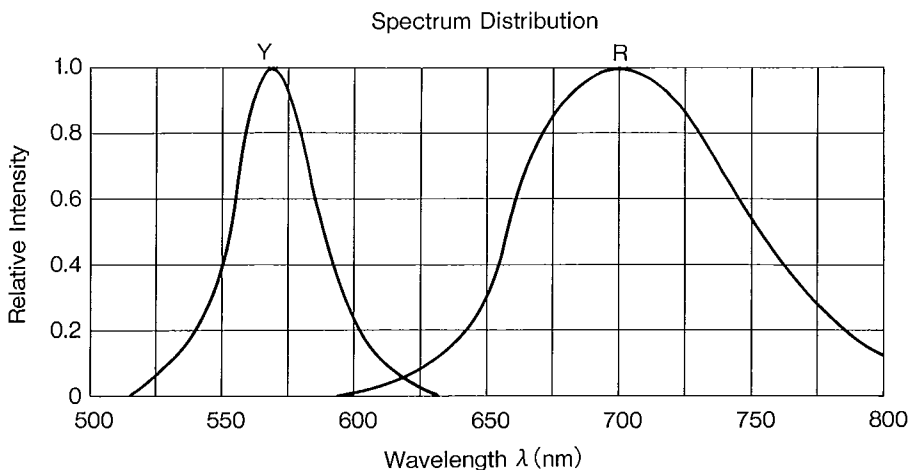

Fig. 1 : Relative Intensity vs. Wavelength

Individual Specifications

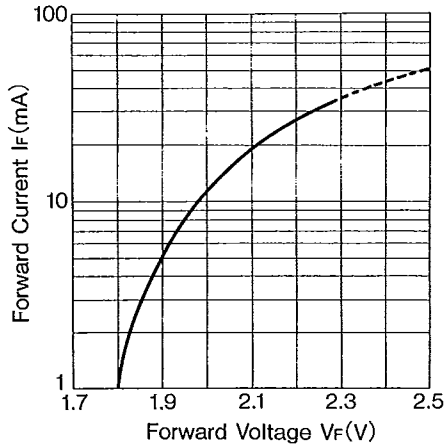

Fig.2 : Forward Current vs. Forward Voltage

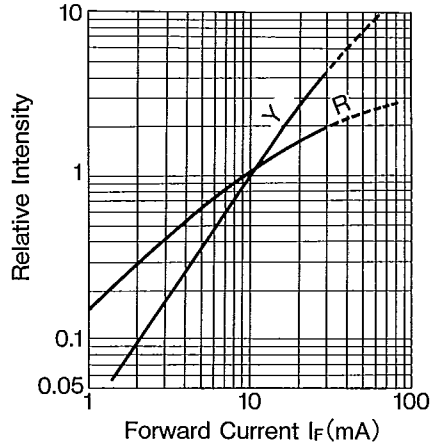

Fig.3 : Relative Intensity vs. Forward Current

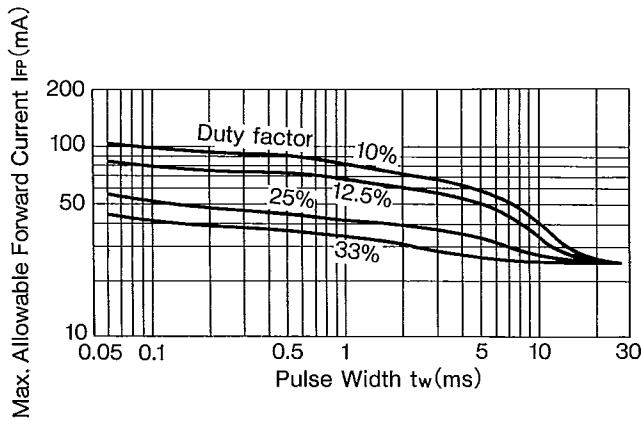

Fig.4 : Max. Allowable Forward Current vs. Pulse Width

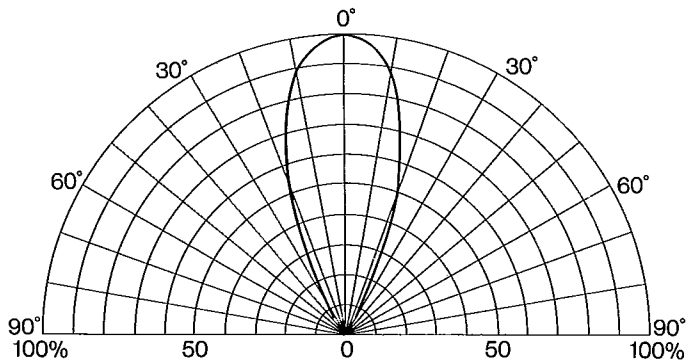

Fig.5 : Viewing Angle