

ZEICHNUNG GESCHÜTZT DURCH
 ©COPYRIGHT 1988
 AMP DEUTSCHLAND GMBH
 ALLE RECHTE VORBEHALTEN

REV.	ÄNDERUNG	DATUM	NAME
2	MASS 2.54 $\begin{smallmatrix} +0.3 \\ -0.1 \end{smallmatrix}$ WAR 2.54 , 2.2 WAR 2.5 MASS 3.0 \pm 0.2 WAR 3.0 HINZU ALLG. TOLERANZ \pm 0.1	02.11.88	AUGUSTINIAK
3	TABELLE HINZU	02.03.89	A.HO
4	ZEICHNUNG IN EUROPEAN PROJECTION GEÄNDERT	04.12.90	A.HO
5	LÖTLÄNGE VON 3.0 IN 3.1 GEÄNDERT	16.03.92	A.HO

DO NOT SCALE
 DIMENSIONS IN mm

METRIC

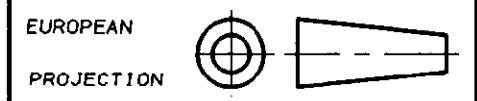

NOTES:

- 1 PLATING: 2.5 μ m Sn
- 2 MATES WITH 0,63 SQUARE/ROUND MODU POSTS.
- 3 CONTACT-POINT.
- 4 RECOMMENDED P.C. BOARD-THICKNESS: 1,6.

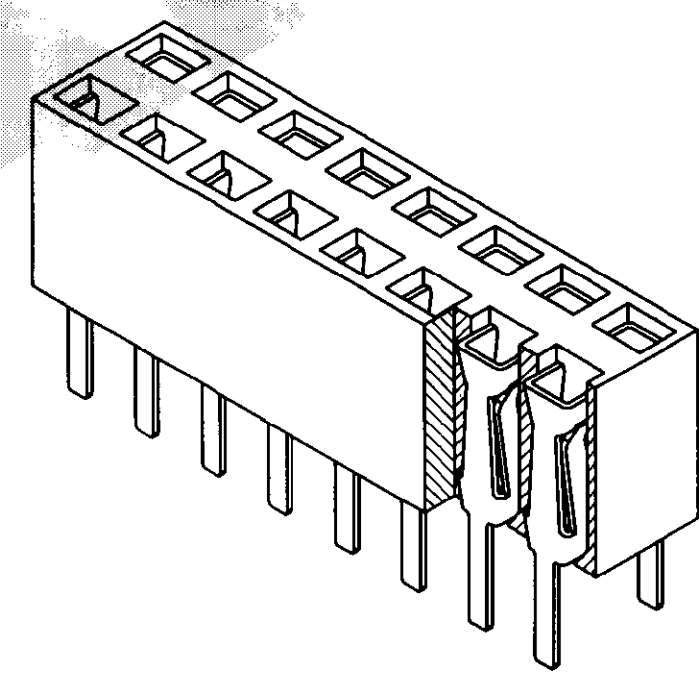
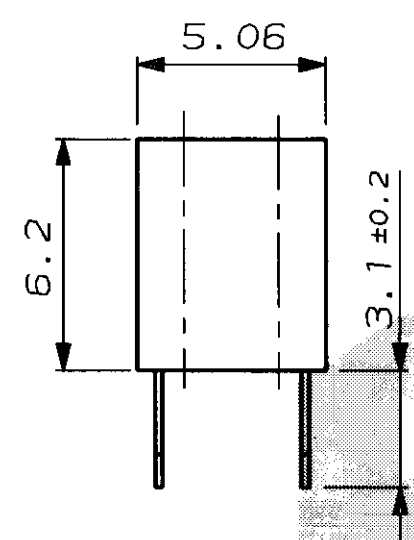
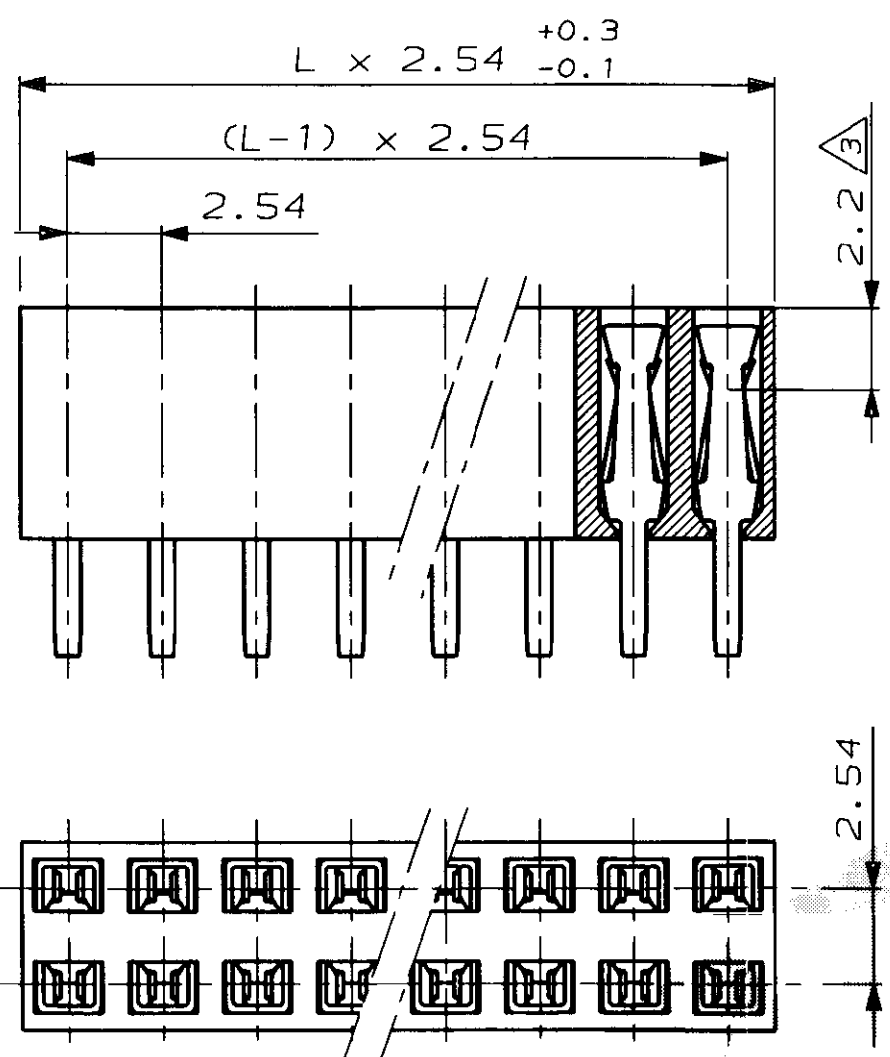

POS. PER ROW	L $\begin{smallmatrix} +0.3 \\ -0.1 \end{smallmatrix}$	PART-NO.
1	2.80	215 316 -1
2	5.08	-2
3	7.62	-3
4	10.16	-4
5	12.70	-5
6	15.24	-6
7	17.78	-7
8	20.32	-8
9	22.86	-9
10	25.40	1-
11	27.94	1-
12	30.48	1-
13	33.02	1-
14	35.56	1-
15	38.10	1-
16	40.64	1-
17	43.18	1-
18	45.72	1-
19	48.26	1-
20	50.80	2-
21	53.34	2-
22	55.88	2-
23	58.42	2-
24	60.96	2-
25	63.50	2-
26	66.04	2-
27	68.58	2-
28	71.12	2-
29	73.66	2-
30	76.20	3-
31	78.74	3-
32	81.28	3-
33	83.82	3-
34	86.36	3-
35	88.90	3-
36	91.44	3- 215 316 -6

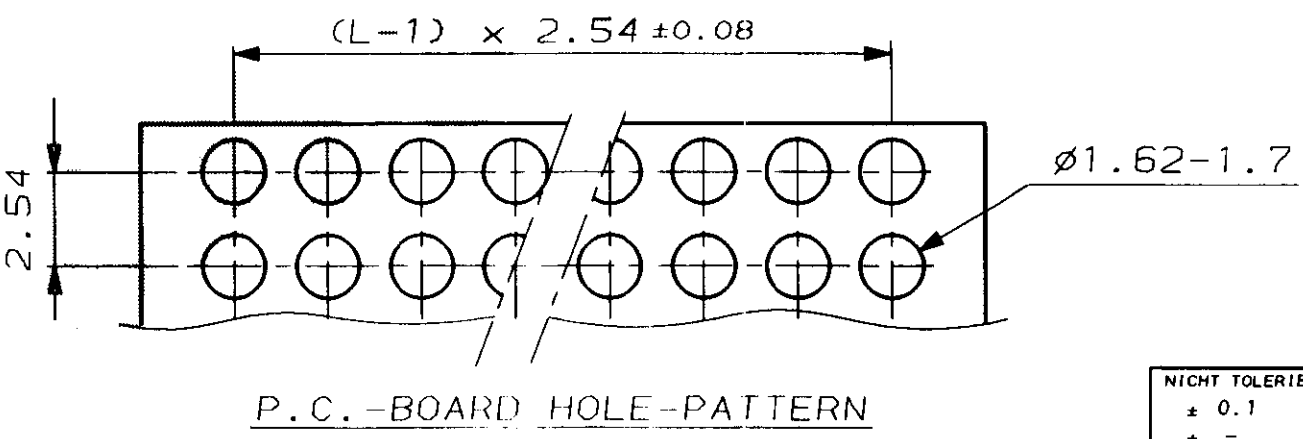

NICHT TOLERIERTE MASSE	± 0.1
MASSTAB	5:1

	△	Cu Sn	REC. CONTACT
	GREEN	PBTP-GV	REC. HOUSING
	FINISH	MATERIAL	DESCRIPTION
CUSTOMER DRAWING	AMP AMP-HOLLAND B.V. 's-Hertogenbosch, The Netherlands.		
	THIS DRAWING IS UNPUBLISHED RELEASED FOR PUBLICATION 14.8.1986		
FOR REFERENCE ONLY WILL NOT BE UPDATED		© COPYRIGHT 1986 BY AMP-HOLLAND B.V. ALL INTERNATIONAL RIGHTS RESERVED. AMP PRODUCTS MAY BE COVERED BY U.S. AND FOREIGN PATENTS AND/OR PATENTS PENDING.	
DR. L.V.D. HEYDEN	DATE 20.05.86	WIRE RANGE -	NAME HV 100 VERTICAL CONNECTOR
CHK.	DATE	INSUL. RANGE -	DUAL ROW, 6,2mm HEIGHT, BOTTOM/TOP ENTRY, TIN, MAX. 2x36 POSITIONS.
APP.	DATE	SIZE A3	SHEET 1 OF 1
		DWG. No. 215 316	REV. DATE D M Y 04 12 90
			REV. LTR. 5

8 | 7 | 6 | 5 | 4 | 3 | 2 | 1