

.100" x .100" Preassembled Wiremount Socket

.050" Pitch Cable (Optional Plastic Strain Relief)

891 Series

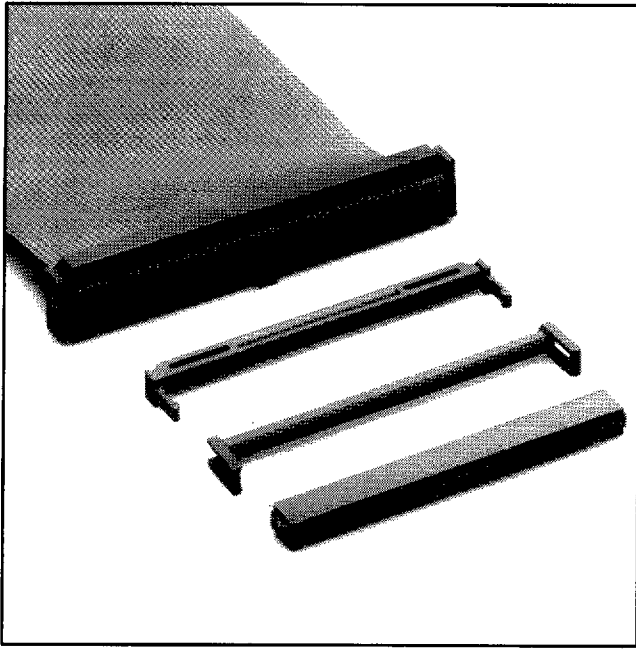

- Fiber-free PVC blister packages of 50
- Preassembled, terminates faster than two-piece sockets
- "Sword" with red stripe indicating pin one, makes easy loading of manual and semi-automatic assembly equipment
- "Bumps" prevent premature latch locking during shipment
- Optional double-sided adhesive pull tab for easy unplugging
- Packaged as two-pieces or bandoliered for automated Shields machines
- Double-recessed cover for cable terminating from either side eliminates need for single-recessed cover-type connectors

34

TS-0449-05
Sheet 1 of 3

Physical

Insulation

Material: Glass Filled Polyester (PBT)
Flammability: UL 94V-0
Color: Gray

Contact

Material: Phosphor Bronze (C510)
Plating
Underplate: 100 μ " [2.54 μ m] Nickel — QQ-N-290, Class 2
Wiping Area: 30 μ " [0.76 μ m] Gold — MIL-G-45204, Type II, Grade C
100 μ " [2.54 μ m] 90/10 Tin Lead

Wire Accommodation: 26 & 28 AWG Stranded

Marking: 3M Logo, Part Identification Number and Orientation Triangle

Electrical

Current Rating: 1 A
Insulation Resistance: $> 1 \times 10^9 \Omega$ at 500 VDC
Withstanding Voltage: 1000 Vrms at Sea Level

Environmental

Temperature Rating: -55°C to $+105^\circ\text{C}$

UL File No.: E68080
CSA File No.: LR 40791

3M Electronic Products Division

6801 River Place Blvd.
Austin, TX 78726-9000

9005413 0000094 947

.100" x .100" Preassembled Wiremount Socket

.050" Pitch Cable (Optional Plastic Strain Relief)

891 Series

CONTACT QUANTITY	DIM. A	DIM. B
10	.68 [17.3]	.54 [13.7]
14	.88 [22.4]	.74 [18.8]
16	.98 [24.9]	.84 [21.3]
20	1.18 [30.0]	1.04 [26.4]
24	1.38 [35.1]	1.24 [31.5]
26	1.48 [37.6]	1.34 [34.0]
30	1.68 [42.7]	1.54 [39.1]
34	1.88 [47.7]	1.74 [44.2]
36	1.98 [50.3]	1.84 [46.7]
40	2.18 [55.4]	2.04 [51.8]
44	2.38 [60.5]	2.24 [56.9]
50	2.68 [68.1]	2.54 [64.5]
60	3.18 [80.8]	3.04 [77.2]

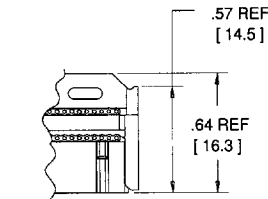
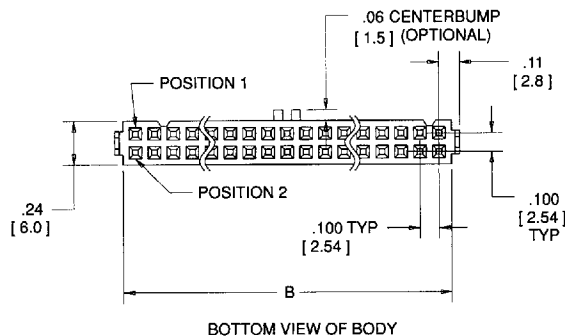
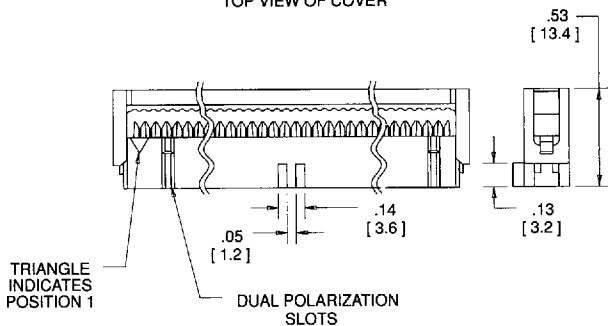
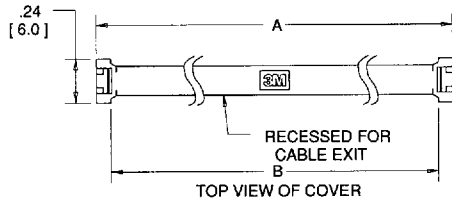
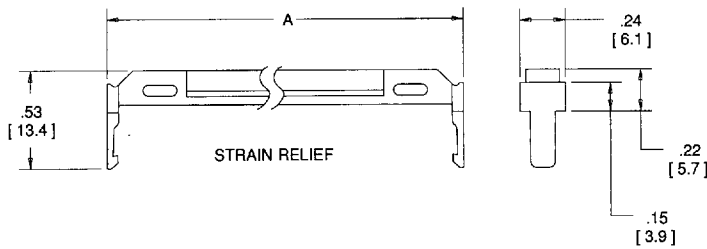

ASSEMBLED HEIGHT WITH STANDARD PLASTIC STRAIN RELIEF

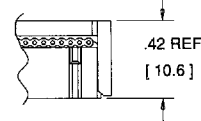

ASSEMBLED HEIGHT WITHOUT STRAIN RELIEF

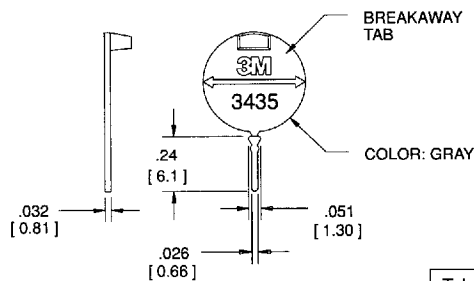

3435-0 KEYING PLUG (OPTIONAL: ORDER SEPARATELY)

Inch [mm]

Tolerance Unless Noted			
	.0	.00	.000
Inch	±.1	±.01	±.005

[] Dimensions for Reference Only

Sheet 2 of 3

TS-0449-05

Ordering Information

Sockets
891XX-0XXX-XX

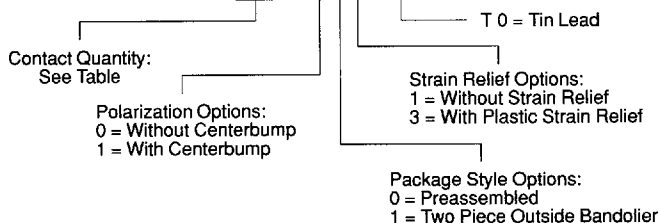

Strain Relief
(Order Separately)
3448-891XX

Contact Quantity:
See Table

.100" x .100" Preassembled Wiremount Socket

.050" Pitch Cable (Optional Plastic Strain Relief)

891 Series

Sheet 3 of 3

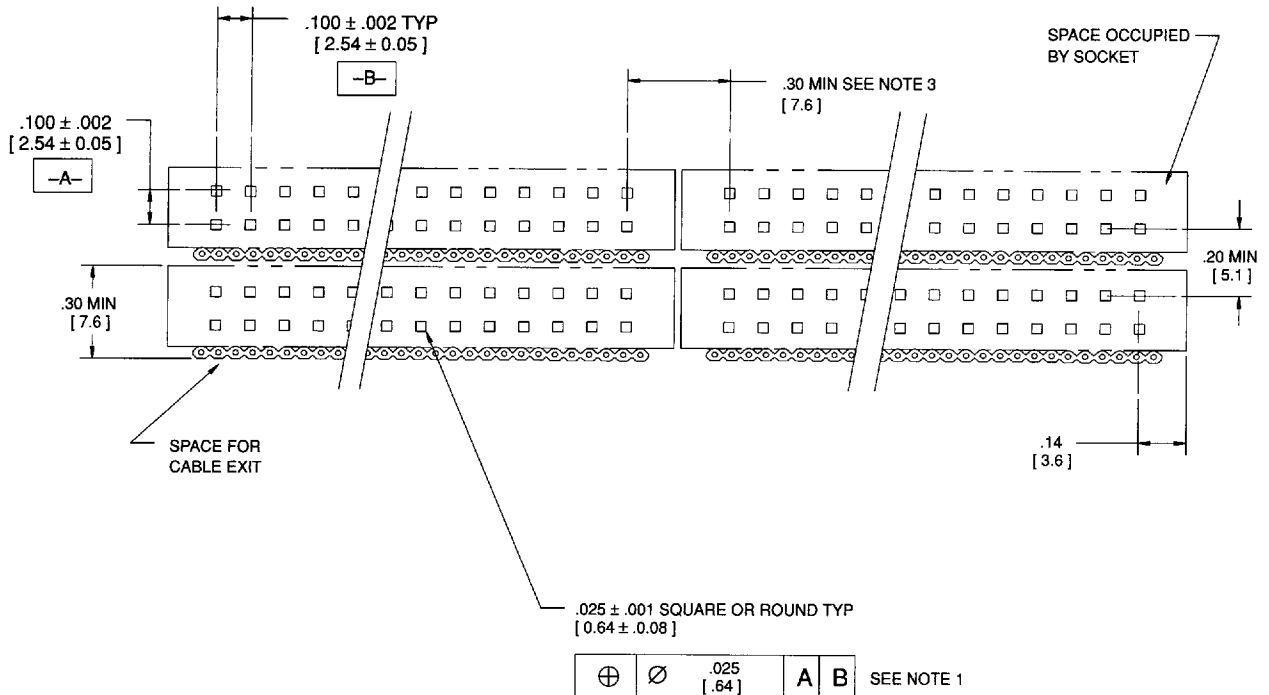

TS-0379-04

- NOTES:
 1. MEASURED AT TIP.
 2. TAPERED PIN TIP CONFIGURATION RECOMMENDED.
 3. ADD .20 [5.1] IF EXTRACTOR TOOL (3M PART NO. 3438) IS USED.

3M Electronic Products Division

6801 River Place Blvd.
 Austin, TX 78726-9000

9005413 0000096 717