

RC4560

Wide-Bandwidth Dual Operational Amplifier

Features

- Unity gain bandwidth ($A_v = 1$) — 10 MHz
- Slew rate — $4.0V/\mu s$
- Noise voltage at 1 kHz — $7.0nV/\sqrt{Hz}$
- Noise voltage current at 1 kHz — $0.4pA/\sqrt{Hz}$
- $\pm 10V$ Output into 400Ω loads ($\pm 25mA$)
- Supply current per amplifier — 1.8mA
- Input offset voltage — 2.0mV
- Input offset current — 5.0nA
- Unity gain frequency compensated
- Output short circuit protected

Description

The RC4560 integrated circuit is a high-gain, wide-bandwidth, dual operational amplifier capable of driving 20V peak-to-peak into 400Ω loads. The RC4560 combines many of the features of the RC4558 as well as providing the capability of wider bandwidth, and higher slew rate make the RC4560 ideal for active filters, data and telecommunication applications, and many instrumentation applications. The availability of the RC4560 in the surface mounted SOIC package allows it to be used in critical applications requiring very high packing densities.

Schematic Diagram (1/2 Shown)

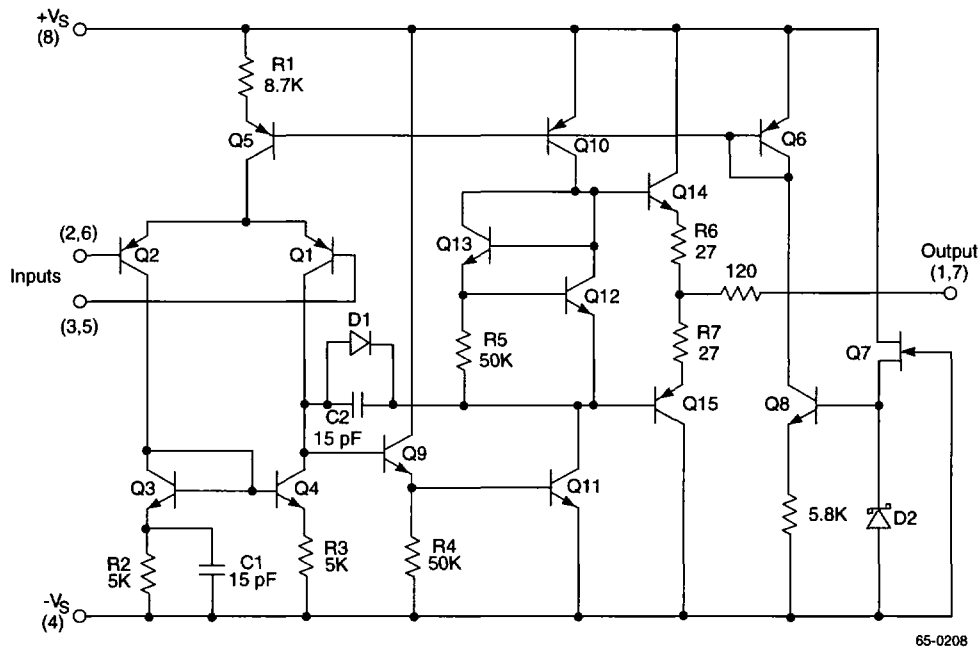

Pin Assignments

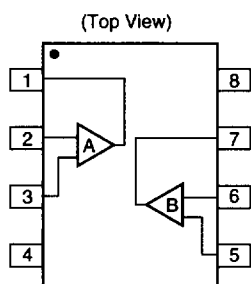

Pin Descriptions

Pin	Function
1	A Output
2	A -Input
3	A +Input
4	+Vs
5	B +Input
6	B -Input
7	B Output
8	-Vs

Thermal Characteristics

	SOIC	Plastic DIP
Max. Junction Temp.	125°C	125°C
Max. PdTA < 50°C	300mW	468mW
Therm. Res. θ_{JC}	—	—
Therm. Res. θ_{JA}	240°C/W	160°C/W
For TA > 50°C Derate at	4.17mW/°C	6.25mW/°C

Absolute Maximum Ratings

(beyond which the device may be damaged)

Parameter	Max.	
Supply Voltage	$\pm 18V$	
Input Voltage ¹	$\pm 15V$	
Differential Input Voltage	30V	
Output Short Circuit Duration ²	Indefinite	
Operating Temperature Range	-20°C to +75°C	
Lead Soldering Temperature	RC4560N	+300°C
	RC4560M	+260°C

Notes:

- For supply voltages less than $\pm 15V$, the absolute maximum input voltage is equal to the supply voltage.
- Short circuit may be to ground on one amp only. Rating applies to +75°C ambient temperature.

Matching Characteristics

(Vs = $\pm 15V$, TA = +25°C)

Parameter	Conditions	Typ.	Units
Voltage Gain	RL $\geq 2 k\Omega$	± 1.0	dB
Input Bias Current		± 15	nA
Input Offset Current		± 7.5	nA
Input Offset Voltage	RS $\geq 10 k\Omega$	± 0.2	mV

Electrical Characteristics

($V_S = \pm 15V$ and $T_A = +25^\circ C$ unless otherwise specified)

Parameters	Test Conditions	Min.	Typ.	Max.	Units
Input Offset Voltage	$R_S \leq 10k\Omega$		2.0	6.0	mV
Input Offset Current			5.0	200	nA
Input Bias Current			50	500	nA
Input Resistance (Differential Mode)		0.3	0.1		M Ω
Large Signal Voltage Gain	$R_L \geq 2k\Omega$, $V_{OUT} = \pm 10V$	20	300		V/mV
Output Voltage Swing	$R_L \geq 10k\Omega$	± 12	± 14		V
	$I_O \geq 25mA$	± 10	± 11.5		
Input Voltage Range		± 12	± 13		V
Common Mode Rejection Ratio	$R_S \leq 10k\Omega$	70	90		dB
Power Supply Rejection Ratio	$R_S \leq 10k\Omega$	76	90		dB
Power Consumption	$R_L = \infty$		135	200	mW
Transient Response	Rise Time	$V_{IN} = 20\text{ mV}$, $R_L = 2k\Omega$	0.05		μS
	Overshoot	$C_L \leq 100pF$	35		%
Slew Rate	$R_L \leq 2k\Omega$, Gain = 1		4.0		V/ μS
Channel Separation	$f = 10kHz$ $R_S = 1k\Omega$, Gain = 100		100		dB
Unity Gain Bandwidth	$A_V = +1$, $V_O = -3dB$		10		MHz
The following specifications apply for $-20^\circ C \leq T_A \leq +75^\circ C$					
Input Offset Voltage	$R_S \leq 10k\Omega$			7.0	mV
Input Offset Current				300	nA
Input Bias Current				800	nA
Large Signal Voltage Gain	$R_L \geq 2k\Omega$, $V_{OUT} = \pm 10V$	15			V/mV
Output Voltage Swing	$R_L \geq 2k\Omega$	± 10			V
Power Consumption	$T_A = +75^\circ C$		135	200	mW
	$T_A = -20^\circ C$		165	230	

Typical Performance Characteristics

Input Bias Current vs. Ambient Temperature

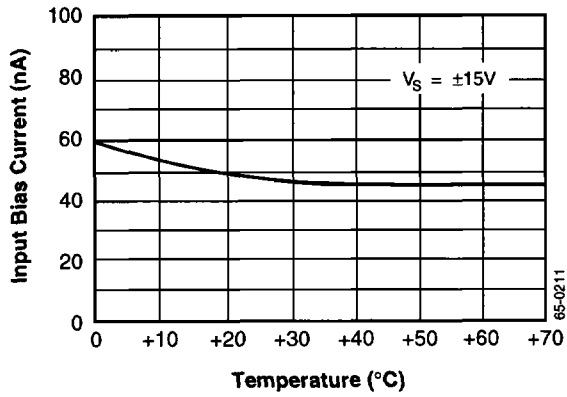

Input Offset Current vs. Ambient Temperature

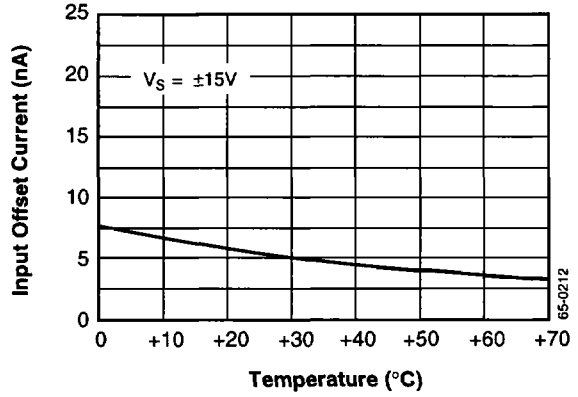

Common Mode Range vs. Supply Voltage

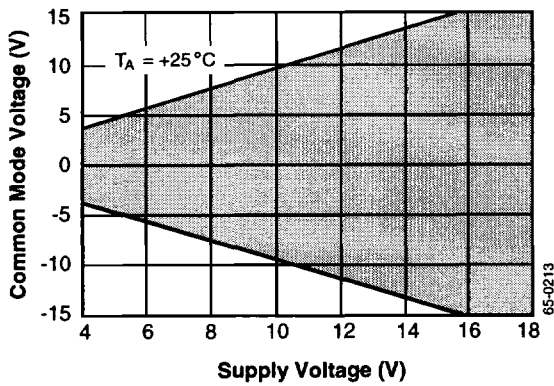

Open Loop Voltage Gain vs. Frequency

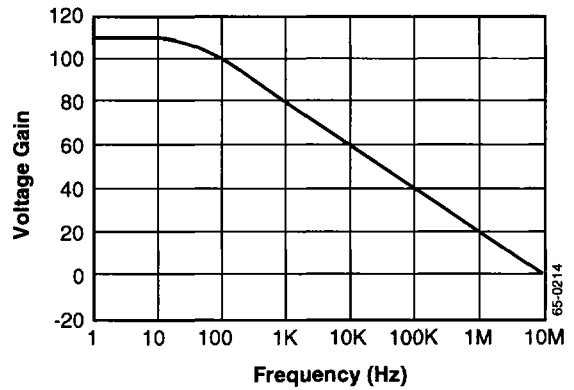

Open Loop Gain vs. Temperature

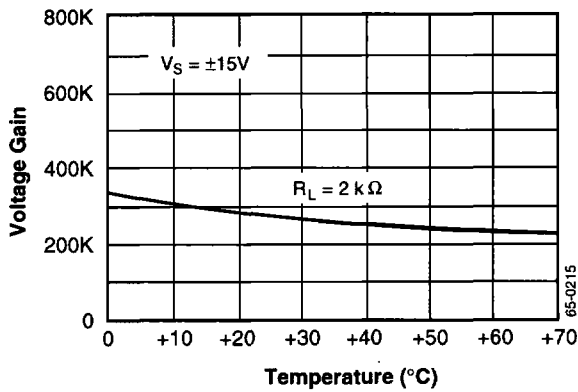

Power Consumption vs. Ambient Temperature

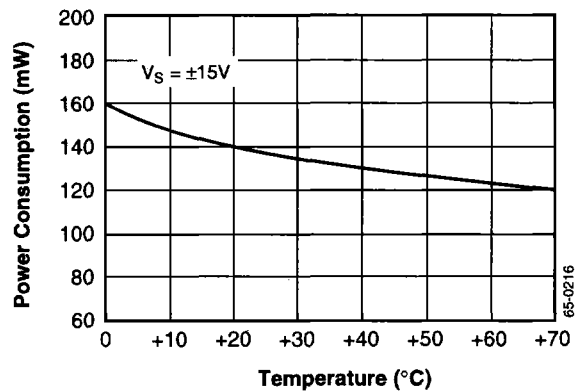

Typical Performance Characteristics (continued)

Typical Output Voltage vs. Supply Voltage

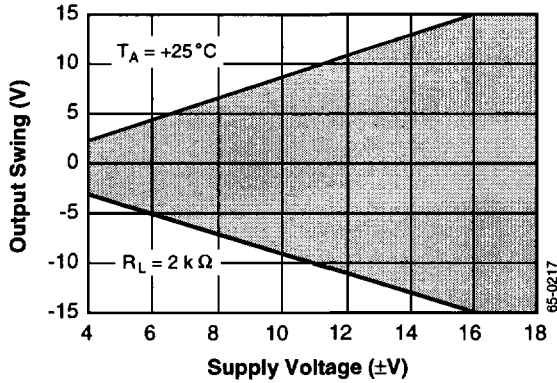

Output Voltage Swing vs. Load Resistance

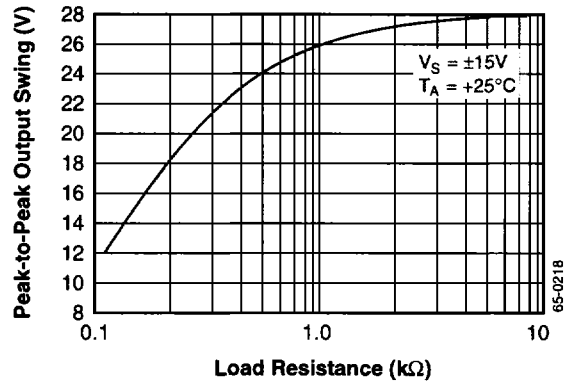

Output Voltage vs. Frequency

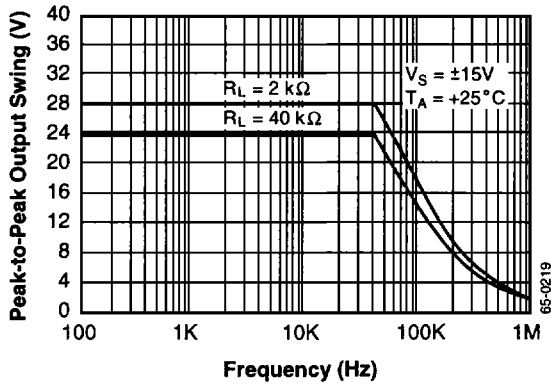

Quiescent Current vs. Supply Voltage

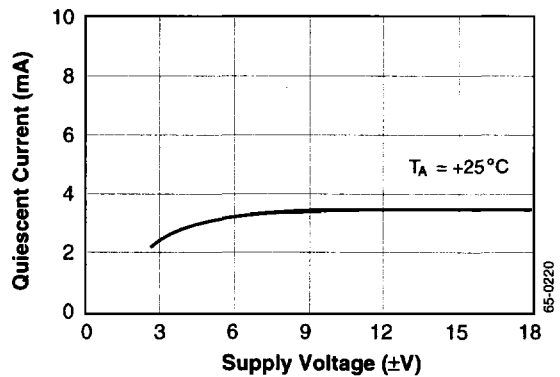

Transient Response

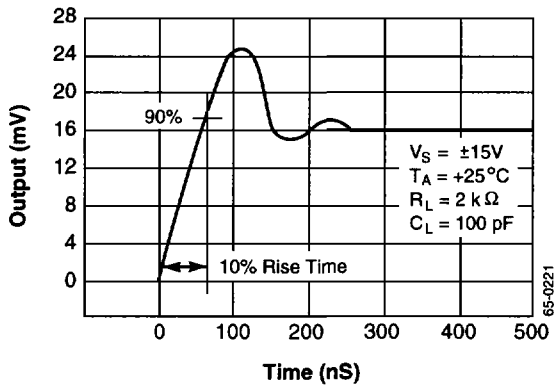

Voltage Follower Large Signal Pulse Response

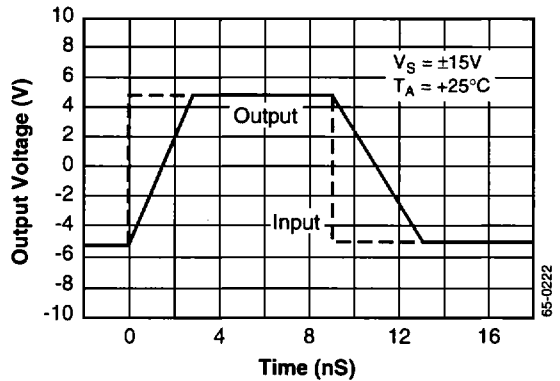

Typical Performance Characteristics (continued)

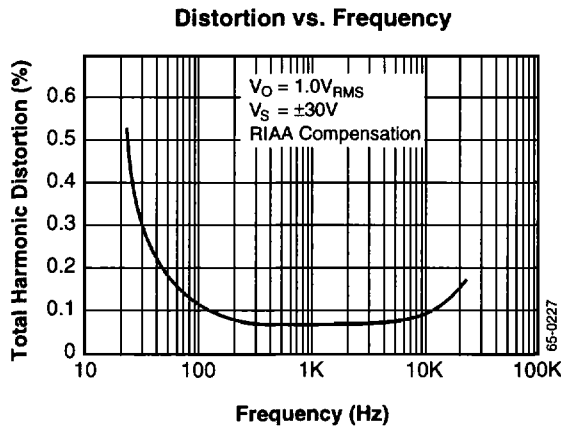
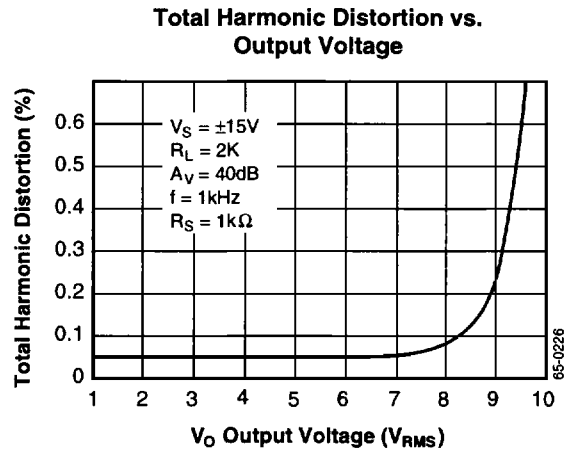
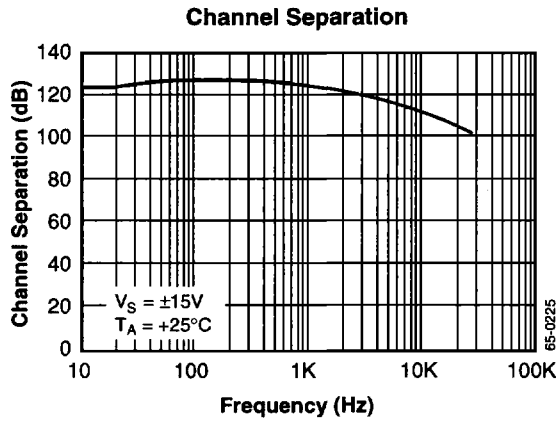
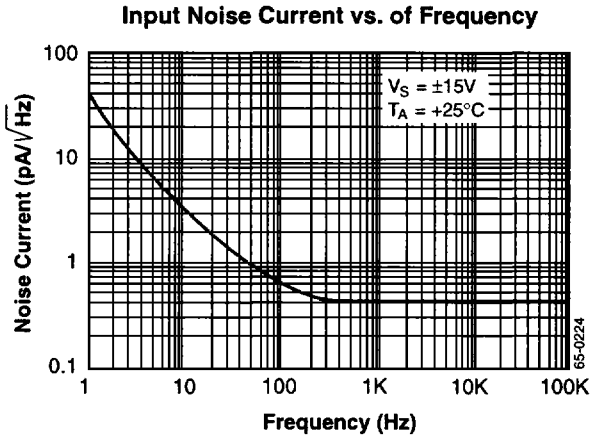
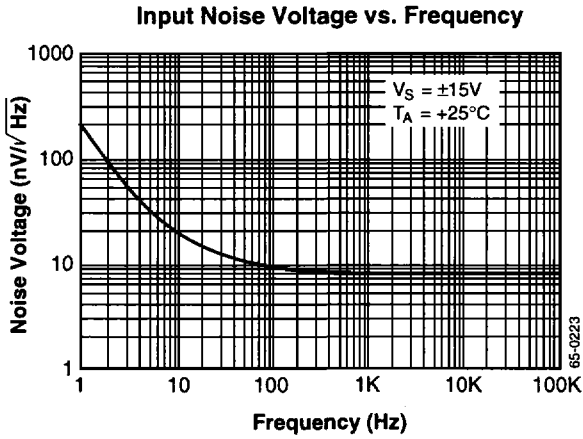

Notes

Notes

Notes

Mechanical Dimensions

Symbol	Inches		Millimeters		Notes
	Min.	Max.	Min.	Max.	
A	.053	.069	1.35	1.75	
A1	.004	.010	0.10	0.25	
B	.013	.020	0.33	0.51	
C	.008	.010	0.20	0.25	5
D	.189	.197	4.80	5.00	2
E	.150	.158	3.81	4.01	2
e	.050 BSC		1.27 BSC		
H	.228	.244	5.79	6.20	
h	.010	.020	0.25	0.50	
L	.016	.050	0.40	1.27	3
N	8		8		6
α	0°	8°	0°	8°	
ccc	—	.004	—	0.10	

Notes:

1. Dimensioning and tolerancing per ANSI Y14.5M-1982.
2. "D" and "E" do not include mold flash. Mold flash or protrusions shall not exceed .010 inch (0.25mm).
3. "L" is the length of terminal for soldering to a substrate.
4. Terminal numbers are shown for reference only.
5. "C" dimension does not include solder finish thickness.
6. Symbol "N" is the maximum number of terminals.

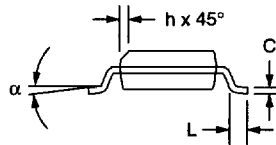
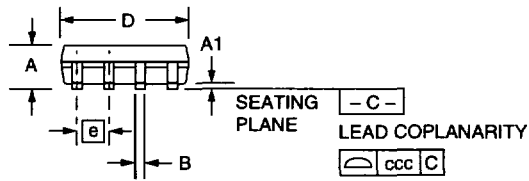
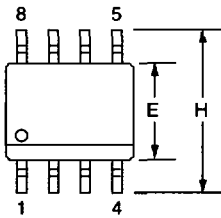

Mechanical Dimensions

8-Lead Plastic DIP Package

Symbol	Inches		Millimeters		Notes
	Min.	Max.	Min.	Max.	
A	—	.210	—	5.33	
A1	.015	—	.38	—	
A2	.115	.195	2.93	4.95	
B	.014	.022	.36	.56	
B1	.045	.070	1.14	1.78	
C	.008	.015	.20	.38	4
D	.348	.430	8.84	10.92	2
D1	.005	—	.13	—	
E	.300	.325	7.62	8.26	
E1	.240	.280	6.10	7.11	2
e	.100 BSC		2.54 BSC		
eB	—	.430	—	10.92	
L	.115	.160	2.92	4.06	
N	8°		8°		5

Notes:

1. Dimensioning and tolerancing per ANSI Y14.5M-1982.
2. "D" and "E1" do not include mold flashing. Mold flash or protrusions shall not exceed .010 inch (0.25mm).
3. Terminal numbers are for reference only.
4. "C" dimension does not include solder finish thickness.
5. Symbol "N" is the maximum number of terminals.

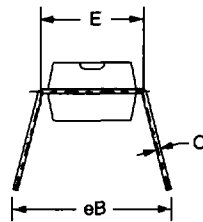
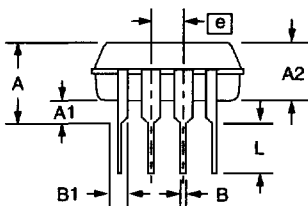
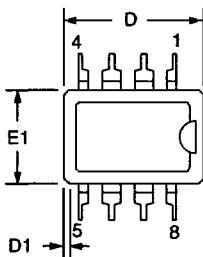

Ordering Information

Product Number	Temperature Range	Package
RC4560M	-20° to +75°C	8-Lead SOIC
RC4560N	-20° to +75°C	8-Lead Plastic DIP

The information contained in this data sheet has been carefully compiled; however, it shall not by implication or otherwise become part of the terms and conditions of any subsequent sale. Raytheon's liability shall be determined solely by its standard terms and conditions of sale. No representation as to application or use or that the circuits are either licensed or free from patent infringement is intended or implied. Raytheon reserves the right to change the circuitry and any other data at any time without notice and assumes no liability for errors.

LIFE SUPPORT POLICY:

Raytheon's products are not designed for use in life support applications, wherein a failure or malfunction of the component can reasonably be expected to result in personal injury. The user of Raytheon components in life support applications assumes all risk of such use and indemnifies Raytheon Company against all damages.

Raytheon Electronics
Semiconductor Division
350 Ellis Street
Mountain View CA 94043
650.968.9211
FAX 650.966.7742