

Single Ended High Frequency PWM Controller

GENERAL DESCRIPTION

The ML4817 High Frequency PWM Controller is optimized for use in single-ended Switch Mode Power Supply designs running at frequencies up to 1MHz. Propagation delays are minimal through the comparators and logic for reliable high frequency operation while slew rate and bandwidth are maximized in the error amplifier. This controller is designed to work in either voltage or current mode.

A unique overload protection circuit helps to limit stress on the output devices. This integrating method of fault detection also provides for reset delay before restart. A 1.5V threshold current limit comparator provides cycle-by-cycle current limit.

The ML4817 oscillator features accurately programmable dead time control to precisely limit the maximum duty cycle.

FEATURES

- Practical Operation at Switching Frequencies to 1MHz
- High Current (2A peak) Totem Pole Output
- Temperature Stable Precise Oscillator Frequency and Dead Time
- Precision Maximum Duty Cycle Limit
- Integrating Fault Detection with Reset Delay
- Fast Shut Down Path from Current Limit to Output
- Output Pulls Low for Under-Voltage Lockout

BLOCK DIAGRAM

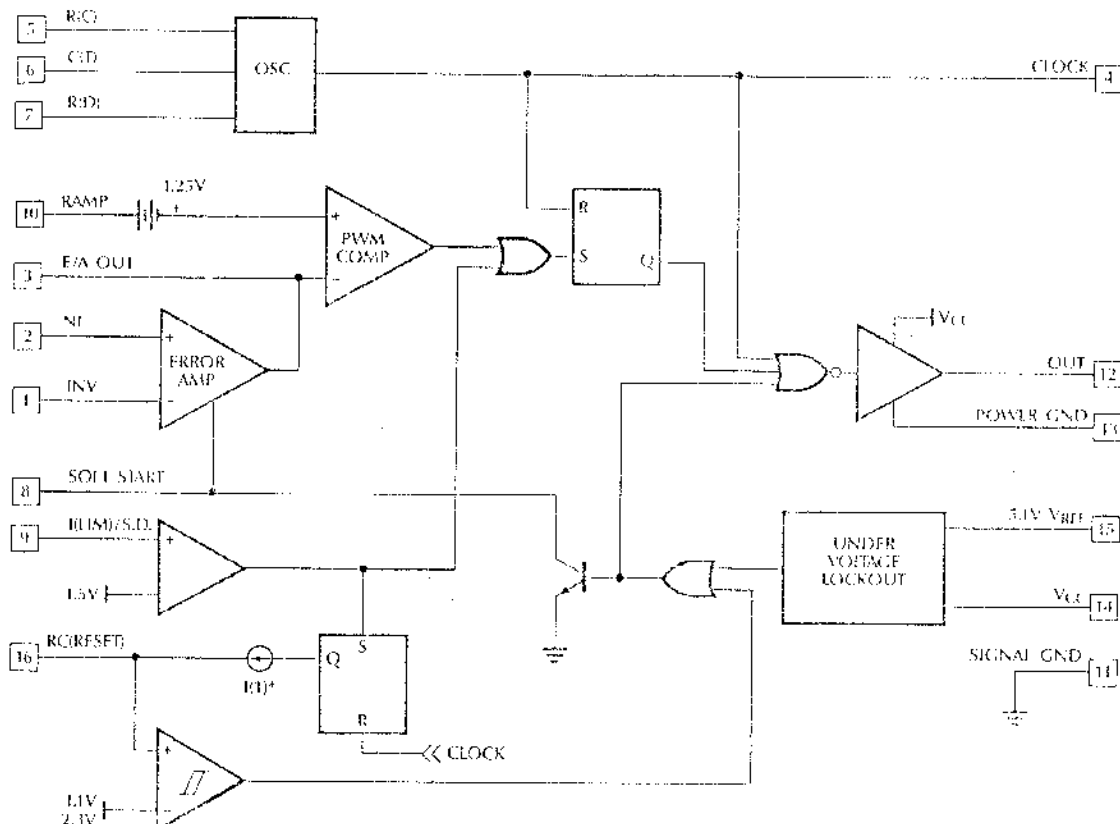

PIN CONFIGURATION

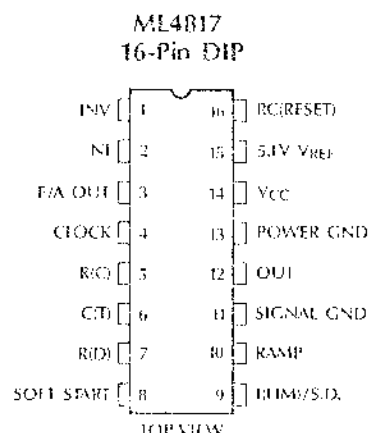
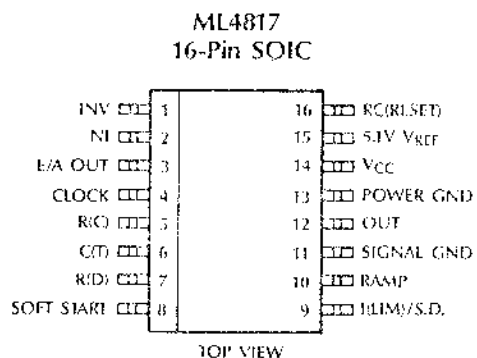

PIN DESCRIPTION

PIN #	NAME	FUNCTION	PIN #	NAME	FUNCTION
1	INV	Inverting input to error amp.	10	RAMP	Non-inverting input to main comparator. Connected to C(T) for Voltage Mode operation or to current sense resistor for current mode.
2	NI	Non-inverting input to error amp.	11	SIGNAL GND	Analog Signal Ground.
3	E/A OUT	Output of error amplifier and input to main comparator.	12	OUT	High Current Totem pole output.
4	CLOCK	Oscillator output.	13	POWER GND	Return for the High Current Totem pole outputs.
5	R(C)	Timing Resistor for Oscillator — sets charging current for oscillator timing capacitor (Pin 6).	14	VCC	Positive Supply for the IC.
6	C(T)	Timing Capacitor for Oscillator.	15	5.1 VREF	Buffered output for the 5.1V voltage reference.
7	R(D)	Resistor which sets discharge current for oscillator timing capacitor.	16	RC(RESET)	Timing elements for integrating fault detection and reset delay circuits.
8	SOFT START	Normally connected to Soft Start Capacitor and charging resistor.			
9	I(LIM)/S.D.	Current limit sense pin. Normally connected to current sense resistor.			

ABSOLUTE MAXIMUM RATINGS

Absolute maximum ratings are those values beyond which the device could be permanently damaged. Absolute maximum ratings are stress ratings only and functional device operation is not implied.

Supply Voltage (Pins 14, 15)	30V
Output Current, Source or Sink (Pin 12)	
DC	0.5A
Pulse (0.5 μ s)	2.0A
Analog Inputs	
(Pins 1, 2, 8, 9, 10, 16)	-0.3 to 6.3V
Clock Output Current (Pins 4)	-5mA
Error Amplifier Output Current (Pin 9)	5mA

Soft Start Sink Current (Pin 8)	100mA
Oscillator Charging Current (Pin 5)	-5mA
Junction Temperature	150°C
Storage Temperature Range	-65°C to 150°C
Lead Temperature (Soldering 10 sec.)	260°C
Thermal Resistance (θ_{JA})	
Plastic DIP	80°C/W
Plastic SOIC	150°C/W

OPERATING CONDITIONS

Temperature Range	0°C to 70°C
-------------------------	-------------

ELECTRICAL CHARACTERISTICS

Unless otherwise specified, R(C) = 2540 Ω , R(D) = 2470 Ω , C_T = 470pF, T_A = Operating Temperature Range, V_{CC} = 15V. (Note 1)

PARAMETER	CONDITIONS	MIN	TYP	MAX	UNITS
Oscillator					
Initial Accuracy	T _A = 25°C	490	525	540	KHz
Voltage Stability	12V < V _{CC} < 25V		0.2		%
Temperature Stability				6	%
Total Variation	line, temp	480		550	KHz
Maximum Duty Cycle	V _{PIN 1} = 2.3V, V _{PIN 2} = 2.5V V _{PIN 9} = V _{PIN 10} = 0V, T _A = 25°C	44	45	46	%
Maximum Duty Cycle	line, temp	42		48	%
C(f) Discharge Current	V _{PIN 6} = 4V, V _{PIN 7} = 3V		4.5		mA
Clock Out High		4.0	4.5		V
Clock Out Low				2.2	V
Ramp Peak			3.75		V
Ramp Valley			2.15		V
Ramp Valley to Peak			1.60		V
Reference					
Output Voltage	T _A = 25°C, I _O = 1mA	5.00	5.10	5.20	V
Line Regulation	12V < V _{CC} < 25V		.2	20	mV
Load Regulation	1mA < I _O < 10mA		.5	20	mV
Temperature Stability	T _{MIN} < T _A < T _{MAX}		.2	.4	mV/°C
Total Variation		4.95		5.25	V
Output Noise Voltage	10Hz to 10KHz		50		μ V
Long Term Stability	T _J = 125°C, 1000 hrs		5	25	mV
Short Circuit Current	V _{REF} = 0V	-15	-50	-100	mA

ELECTRICAL CHARACTERISTICS (Continued)

PARAMETER	CONDITIONS	MIN	TYP	MAX	UNITS
Error Amplifier					
Input Offset Voltage				15	mV
Input Bias Current			.6	3	μ A
Input Offset Current			.1	1	μ A
Open Loop Gain	$1 < V_O < 4V$	60	95		dB
CMRR	$1.5 < V_{CM} < 5.5V$	60	95		dB
PSRR	$12 < V_{CC} < 25V$	80	110		dB
Output Sink Current	$V_{PIN\ 3} = 1V$	1	2.5		mA
Output Source Current	$V_{PIN\ 3} = 4.0V$	-1.5	-1.3		mA
Output High Voltage	$I_{PIN\ 3} = -0.5mA$	5.3			V
Output Low Voltage	$I_{PIN\ 3} = 1mA$	0	0.5	1.0	V
Unity Gain Bandwidth		3	5.5		MHz
Slew Rate		6	12		V/ μ s
PWM Comparator					
Pin 10 Bias Current	$V_{PIN\ 10} = 0V$		-1	-5	μ A
Pin 3 Zero D.C. Threshold	$V_{PIN\ 10} = 0V$	1.2	1.5	1.8	V
Delay to Output			50	80	ns
Soft Start					
Pin 8 Bias Current	$V_{PIN\ 8} = 4V$			10	μ A
Discharge Current	$V_{PIN\ 8} = 1V$	10			mA
Current Limit/Shutdown					
Pin 9 Bias Current	$0V < V_{PIN\ 9} < 4V$			+10	μ A
Current Limit Threshold	$V_{PIN\ 16} = 0V$	1.35		1.65	V
Delay to Output			40	70	ns
Pin 16 Shutdown Threshold		2.05		2.55	V
Pin 16 Restart Threshold		0.9		1.3	V
Pin 16 Charging Current	$V_{PIN\ 9} = 2V, V_{PIN\ 16} = 1.5V$	-150	-210	-275	μ A
Output					
Output Low Level	$I_{OUT} = 20mA$.25	.4	V
	$I_{OUT} = 200mA$		1.2	2.2	V
Output High Level	$I_{OUT} = -20mA$	12.0	13.5		V
	$I_{OUT} = -200mA$	11.5	13.0		V
Rise/Fall Time	$C_L = 1000pF$		30	60	ns
Under-Voltage Lockout					
Start Threshold		12.0	13.8	15.0	V
UVLO Hysteresis		3.0	3.6	4.2	V
Supply Current					
Start Up Current			1.8	2.57	mA
I_{CC}	$V_{PIN\ 1} = 2.3V, V_{PIN\ 2} = 2.5V$ $V_{PIN\ 9, 10} = 0V, C_L = 0, T_A = 25^\circ C$		34	46	mA

Note 1: Limits are guaranteed by 100% testing, sampling, or correlation with worst-case test conditions.

FUNCTIONAL DESCRIPTION

OSCILLATOR

The ML4817 oscillator charges the external capacitor, C_T , with a current (I_{SET}) equal to $2/R_C$. When the C_T voltage reaches the upper threshold (Ramp Peak), the comparator changes state, turning off the current source and turning on the 4.5mA current sink which is voltage clamped to 1.05V by Q1. The capacitor then discharges to the lower threshold (Ramp Valley) with a time constant determined by R_D and C_T .

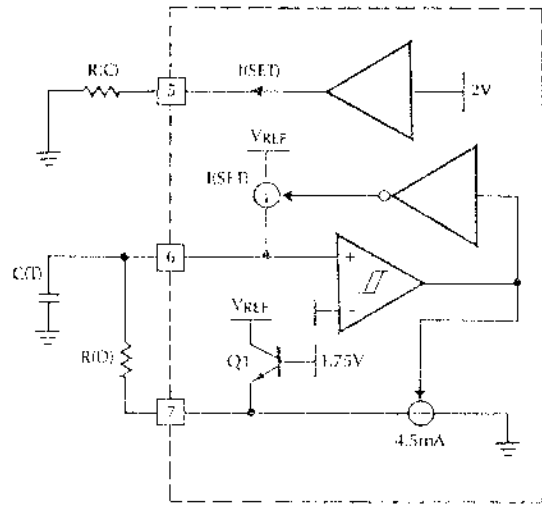
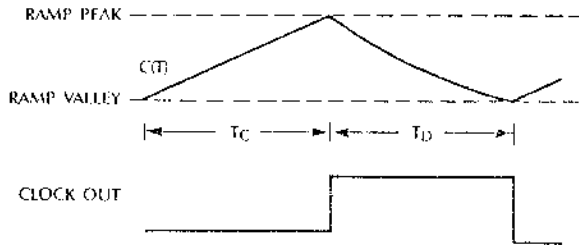

Figure 1. Oscillator Block Diagram

Oscillator period can be determined by the following formula:

$$T_{OSC} = T_C + T_D \quad (1)$$

$$T_C = \frac{(\text{RAMP PEAK} - \text{VALLEY}) C_T R_C}{2} \quad \text{or} \quad (2)$$

$$T_C = 0.8 (C_T R_C) \quad (2)$$

$$T_D = R_D C_T \ln \left(\frac{\text{RAMP PEAK} - 1.05}{\text{RAMP VALLEY} - 1.05} \right) \quad \text{or} \quad (3)$$

$$T_D = 0.90 (R_D C_T) \quad (3)$$

$$\text{since: } f_{OSC} = \frac{1}{T_C + T_D}$$

$$\text{then: } f_{OSC} = \frac{1}{C_T (.8R_C + .90R_D)} \quad (4)$$

$$\text{since: } \text{Duty Cycle} = \frac{T_C}{T_C + T_D}$$

$$\text{then: } \text{Duty Cycle} = \frac{1}{1 + 1.125 \left(\frac{R_D}{R_C} \right)} \quad (5)$$

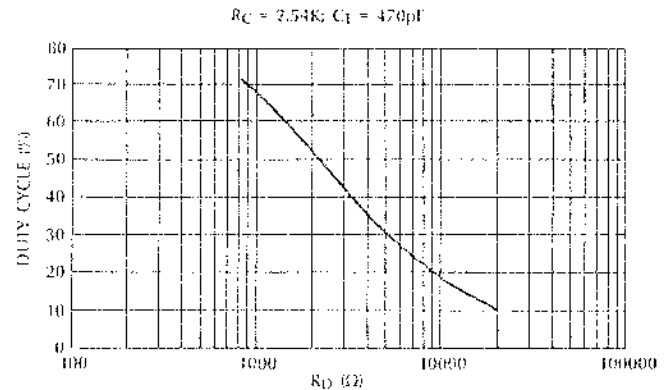

Figure 2. Duty Cycle vs R(D)

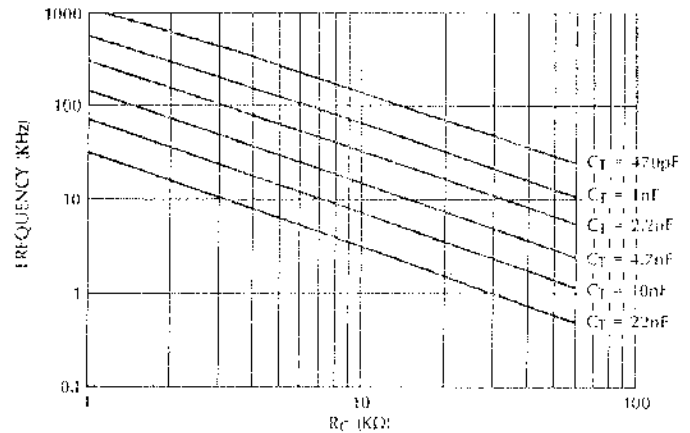

Figure 3. Oscillator Frequency vs $R_D = \frac{R_C}{1.03}$
R(C) for 50% Duty Cycle

ERROR AMPLIFIER

The ML4817 error amplifier is a 5.5MHz bandwidth, 12V/ μ s slew rate op-amp with provision for limiting the positive output voltage swing for ease in implementing the soft start function.

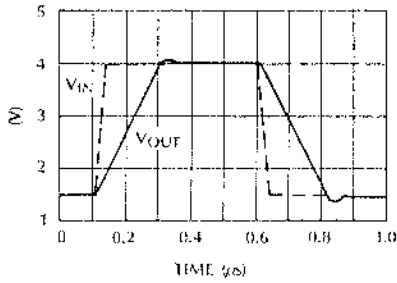

Figure 4. Unity Gain Slew Rate

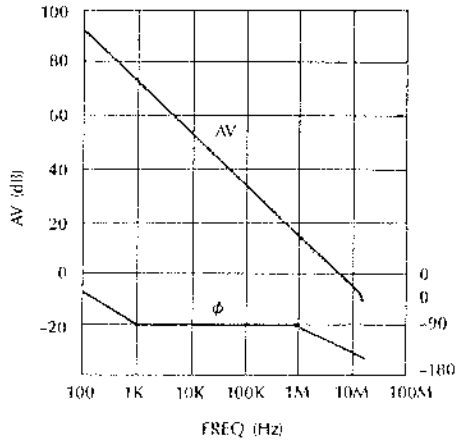

Figure 5. Open Loop Frequency Response

OUTPUT DRIVER STAGE

The ML4817 Output Driver is a 2A peak output high speed totem pole circuit designed to quickly switch capacitive loads, such as power MOSFET transistors.

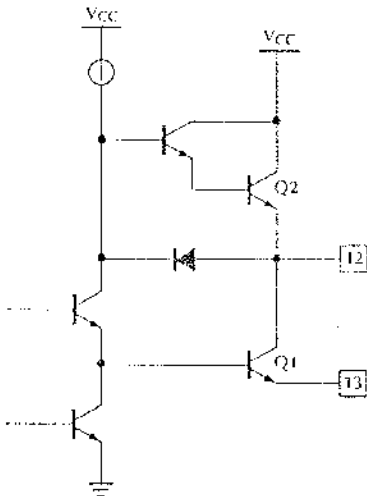
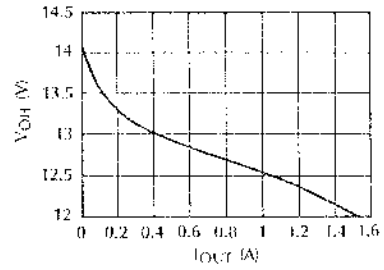

Figure 6. Power Driver Simplified Schematic

V_{OH} Curve



V_{OL} Curve

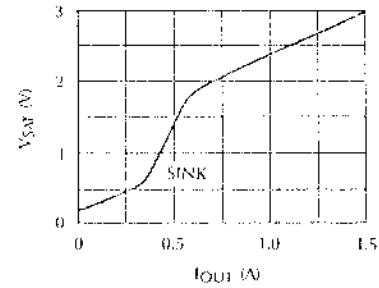

Figure 7. Saturation Curves

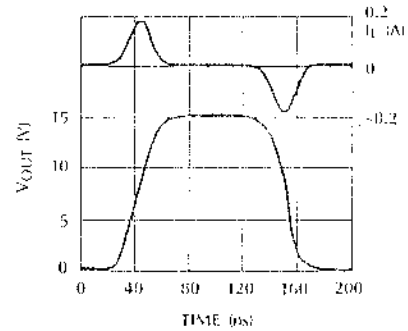

Figure 8. Rise/Fall Time ($C_L = 1000\text{pF}$)

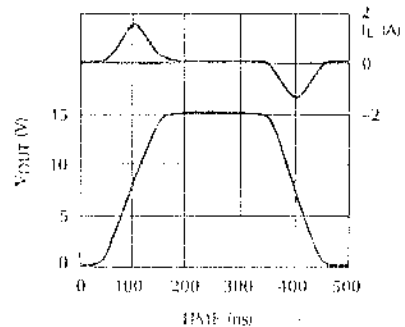

Figure 9. Rise/Fall Time ($C_L = 10,000\text{pF}$)

UNDER-VOLTAGE LOCKOUT

When V_{CC} is below 13.8V, the IC draws very little current (1.8mA typ.) and V_{REF} is disabled. When V_{CC} rises above 13.8V, the IC becomes active and V_{REF} is enabled and will stay in that condition until V_{CC} falls below 10.2V.

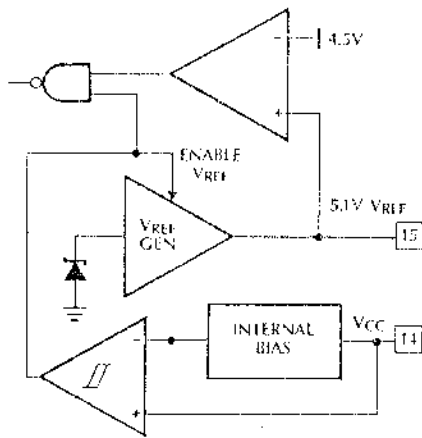

Figure 10. Under-Voltage Lockout Circuit

CURRENT LIMIT, FAULT DETECTION AND SOFT START

When the current sensed on pin 9 reaches the 1.5V limit, the PWM cycle is terminated. The flip flop (figure 11) turns on current source I(1) to charge C_{RST} and remains on until CLOCK goes high. The magnitude of current source I(1) is $.25 \times I_{SET}$ where I_{SET} is the oscillator charging current. When C_{RST} has charged to 2.3V, a soft start reset occurs. The number of times the PWM cycle is terminated due to over-current is "remembered" on C(RST). Over time, C(RST) is discharged by R(RST) providing a measure of "forgetting" when the over-current condition no longer occurs.

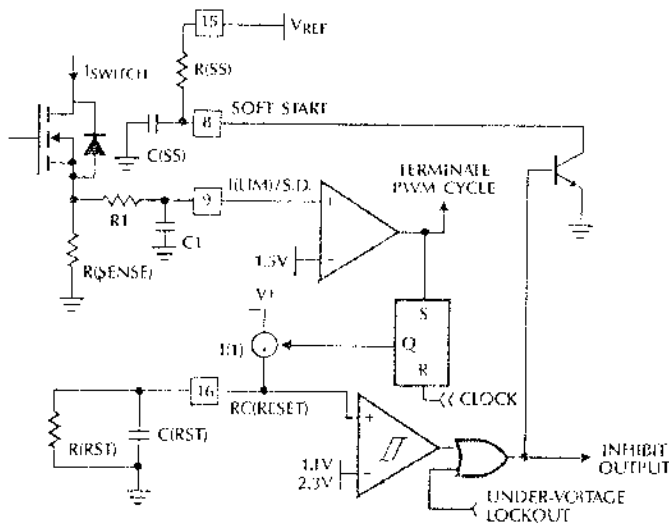

Figure 11. Over-Current, Soft Start, and Integrating Fault Detect Circuits

Since the per cycle charge on RC(RESET) is proportional to how early in the PWM cycle the reset occurs, a reset will occur more quickly under output short circuit conditions (figures 12c and 12d) than during a load surge (figures 12a and 12b).

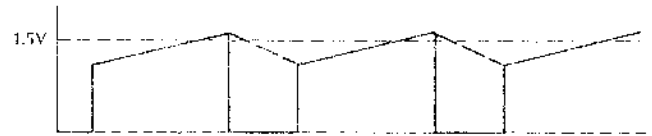

Figure 12a. Pin 9 (I_{LIMIT}) Waveform During Load Surge

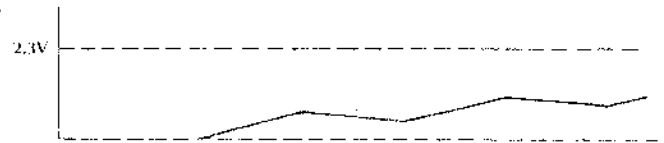

Figure 12b. Corresponding Waveform on Pin 16 (RC_{RESET})

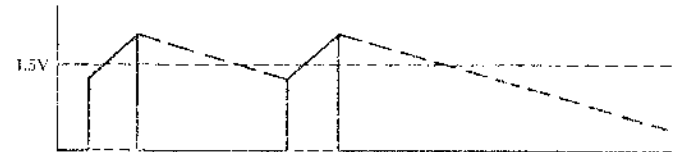

Figure 12c. Current Waveform During Short Circuit (Pin 9)

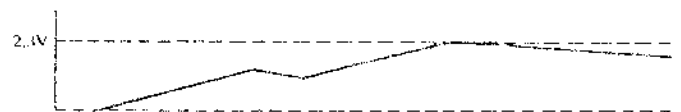

Figure 12d. RC(RESET) (Pin 16) Increases More Quickly During Short Circuit Condition

When the soft start reset occurs, the output is inhibited and the soft start capacitor is discharged. The output will remain off until C(RST) discharges to 1.1V through R(RST), providing a reset delay. When the IC restarts, the error amplifier output voltage is limited to the voltage at pin 8, thus limiting the duty cycle.

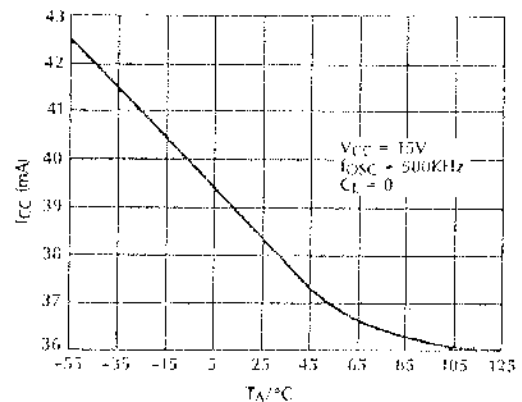

Figure 13. Supply Current vs. Temperature

ORDERING INFORMATION

PART NUMBER	TEMPERATURE RANGE	PACKAGE
ML4817CP	0°C to +70°C	DIP (P16)
ML4817CS	0°C to +70°C	SOIC (S16W)