

NUMBER
178751

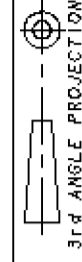

METRIC

CONFIDENTIAL INFORMATION

DIMENSIONS IN MILLIMETERS. DO NOT SCALE PRINT

PRINT DIST

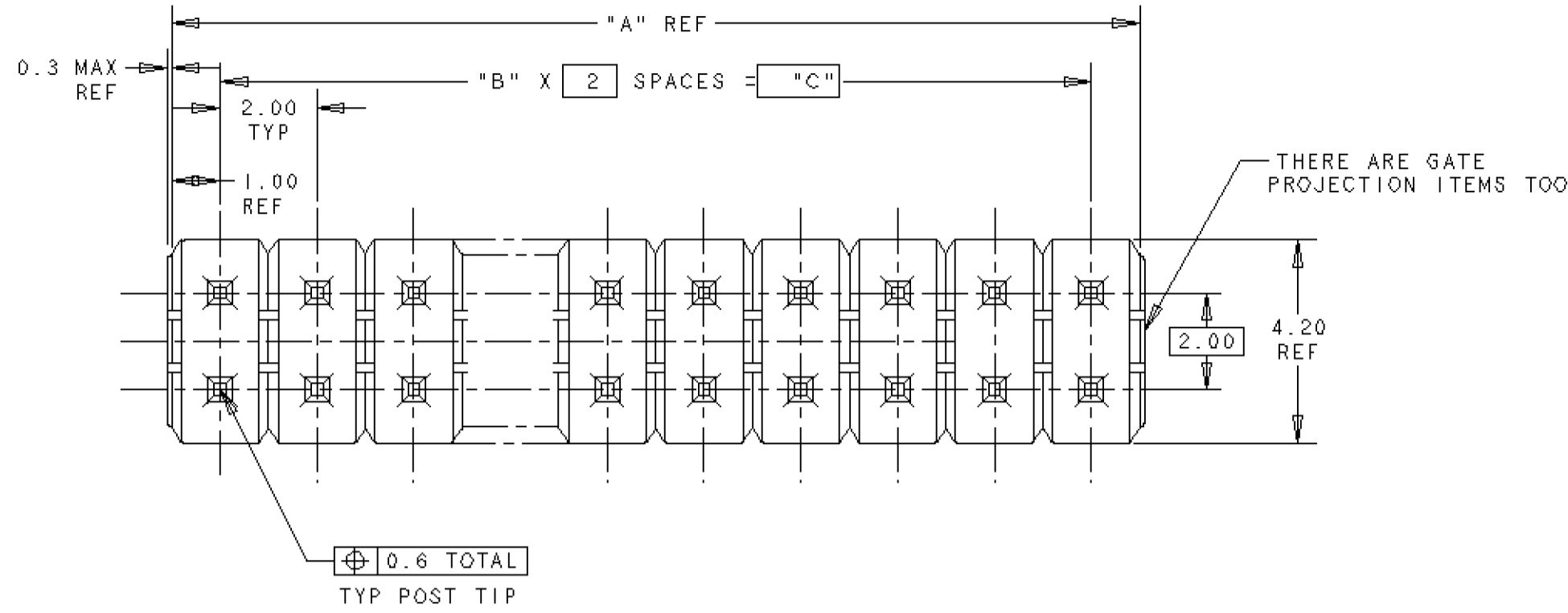

NOTES:

- △ MATERIAL
- △ FINISH

HOUSING: THERMOPLASTIC, UL94V-0,
POST: BRASS
CONTACT AREA: 'D' MIN Au ON
NICKEL 0.0013 MIN ALL OVER
POST TIME: 0.001 MIN TIN-LEAD

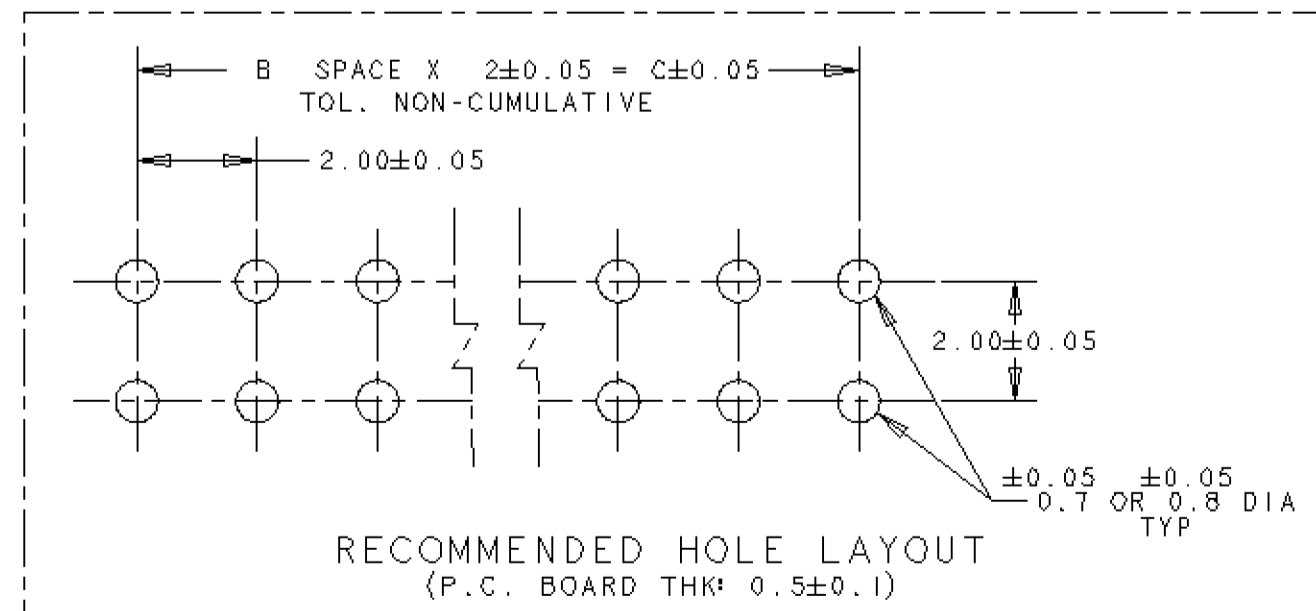
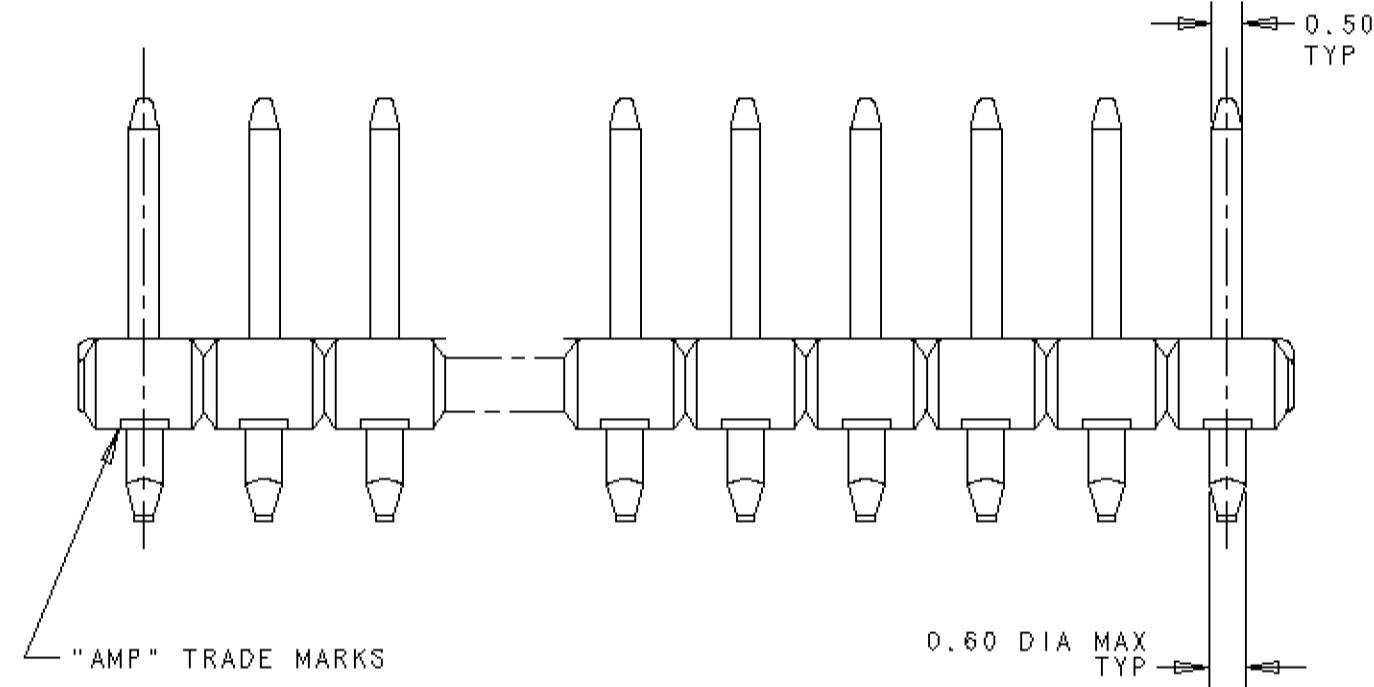
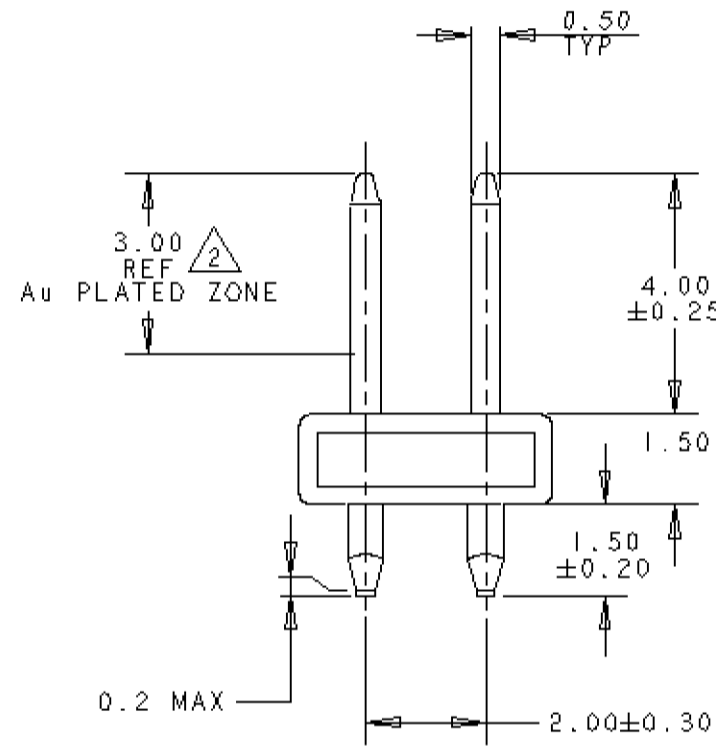

	0.00078	—	—	2	2	5-	-0
	0.0002	—	—	2	2	4-	-9
	↑	48	24	50	50	4-	-8
		46	23	48	48	4-	-7
		44	22	46	46	4-	-6
		42	21	44	44	4-	-5
		40	20	42	42	4-	-4
		38	19	40	40	4-	-3
		36	18	38	38	4-	-2
		34	17	36	36	4-	-1
		32	16	34	34	4-	-0
		30	15	32	32	3-	-9
		28	14	30	30	3-	-8
		26	13	28	28	3-	-7
OBSOLETE		24	12	26	26	3-	-6
		22	11	24	24	3-	-5
		20	10	22	22	3-	-4
OBSOLETE		18	9	20	20	3-	-3
		16	8	18	18	3-	-2
		14	7	16	16	3-	-1
		12	6	14	14	3-	-0
		10	5	12	12	2-	-9
		8	4	10	10	2-	-8
		6	3	8	8	2-	-7
		4	2	6	6	2-	-6
	0.00078	2	1	4	4	2-	-5
	↑	48	24	50	50	2-	-4
		46	23	48	48	2-	-3
		44	22	46	46	2-	-2
		42	21	44	44	2-	-1
		40	20	42	42	2-	-0
		38	19	40	40	1-	-9
		36	18	38	38	1-	-8
		34	17	36	36	1-	-7
		32	16	34	34	1-	-6
		30	15	32	32	1-	-5
		28	14	30	30	1-	-4
OBSOLETE		26	13	28	28	1-	-3
		24	12	26	26	1-	-2
		22	11	24	24	1-	-1
		20	10	22	22	1-	-0
		18	9	20	20		-9
		16	8	18	18		-8
OBSOLETE		14	7	16	16		-7
		12	6	14	14		-6
OBSOLETE		10	5	12	12		-5
		8	4	10	10		-4
OBSOLETE		6	3	8	8		-3
		4	2	6	6		-2
	0.0002	2	1	4	4		178751-1
STATUS	"D"	"C"	"B" SPACES	"A" REF	NO OF POS	ASS'Y P/N	

Copyright ©1991 AMP MANUFACTURING (SINGAPORE) PTE LTD. ALL RIGHTS RESERVED

AMP AMP MANUFACTURING (SINGAPORE) PTE. LTD.

WIRE RANGE: — mm² (AWG) — INSULATION DIA: — mm

MATERIAL: SEE NOTE △ FINISH: SEE NOTE △

DR. 16APR91 DE. 16APR91
I. ENOMOTO I. ENOMOTO
CHK. 27MAY91 APP. SF LEONG
T. DOI

AMP MODU 2MM PITCH POST HOR. V-TYPE, L=1.5

GENERAL TOLERANCE: 0<* 10 : ±0.2
10<* 30 : ±0.25
30<* 100 : ±0.3
ANGLES : ±*

SIZE: A2 LOC: DY NUMBER: 178751
SCALE: 8:1 REV. C SHEET: 1 OF 1

- [Home](#)
- [Part Number Search](#)
- [Text Search](#)
- [Alternate Part Search](#)
- [Multiple Part Comparison](#)
- [Alphabetical Search](#)
- [Brand Search](#)
- [Industry Product Search](#)
- [Product Type Search](#)
- [Product Family Search](#)
- [Competitor Cross Reference](#)
- [Document Number Search](#)
- [Lead Free Solutions](#)
- [Help/Glossary](#)

Current Brand View

AMP

[View All Tyco Electronics Brands](#)

Click to activate links to all other products

AMPMODU

2mm Centerline (AMPMODU) Board-to-Board Connectors

AMP

2-178751-5 -- 4 of 5 products

Active

[Active](#)

(Tyco Electronics P/N: 2-178751-5)

Previous	Next	Sales Information	AMP ACES	Step Search Screen
			Related Documents	General Information
			Pricing	Product Availability

Please use the customer drawing for all design activity.

- **Customer Drawing: 178751, Rev. C**

Document Title: AMPMODU 2MM PITCH POST HOR. V-TYPE, L=1.5

[209531.pdf](#) [209531.pdf](#) (48K)

The photographs and/or line drawings below are representative images of a product for viewing purposes only.

[Recommended PC Board Hole](#)

[Layout](#)

Searchable Features:

Brand:	AMP
Product Type:	Header
PCB Mount Style:	Thru Hole
Header Type:	Breakaway
No. of Positions:	4
PCB Mount Angle:	Vertical
Contact Material:	Brass
Keyed:	No
Contact Mating Area Plating:	Gold (30)
Mating Post Length (mm [in]):	4.00 [.158]
Termination Post Length (mm [in]):	1.50 [.059]
Holddown Feature:	Without
Post Number(s) Omitted:	None
Packaging Method:	Box

Other Properties:

Housing Material:	Thermoplastic
Centerline Spacing (mm [in]):	2.00 x 2.00 [.079 x .079]
Housing Material Flammability Rating:	UL 94V-0
Housing Color:	Black
Solder Tail Plating:	Tin-Lead
PCB Thickness (mm [in]):	.51 [.020]
Post Size (mm [in]):	0.50 [.020] Sq.
PCB Retention Feature:	Without
Selectively Loaded:	No
Sealed:	No
No. of Rows:	2
Shrouded:	No

[Copyright](#) and [Privacy Statement](#)

Visit [Tyco International, Ltd.](#)

[Products](#) | [Brands](#) | [Industries](#) | [Customer Service](#) | [About](#) | [Home](#)