

.100" (2.54mm) Dual Row, Surface Mount, Vertical Header



9100 SERIES ("POST/BOXE")

PART NUMBER LEGEND

910X-21-2XX-XX

PIN NUMBER
(SEE TABLE 2)

NUMBER OF POSITIONS PER ROW
(SEE TABLE 1)

PIN FINISH PLATING
(SEE NOTE 2)

MATING CONNECTORS: 9000 SERIES

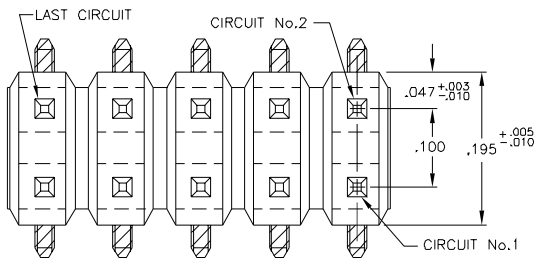

NOTES:

1. INSULATOR MATERIAL: POLYESTER (PET), 30% G/R, UL 94V-0.

2. PIN MATERIAL: PHOSPHOR BRONZE.

3. PIN FINISH:

9100 - BRIGHT TIN OVER NICKEL PLATE.

910B - .00050/.000150 NICKEL PLATE ALL OVER; .000030 SEL. GOLD PLATE AS INDICATED; .0001-.0002 SEL. 90/10 TIN/LEAD ON SOLDER TAIL AS INDICATED.

910E - .00050/.000150 NICKEL PLATE ALL OVER; .000015 SEL. GOLD PLATE AS INDICATED; .0001-.0002 SEL. 90/10 TIN/LEAD ON SOLDER TAIL AS INDICATED.

PART NUMBER	DIM. "C"	DIM. "D"
910X-21-2XX-01	.230	.160
-02	.320	.200
-03	.405	.200

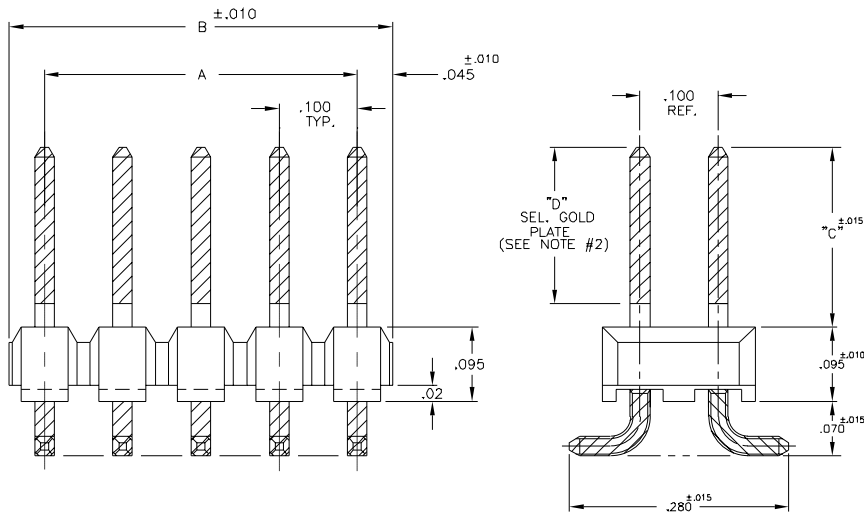

PART NUMBER	No. of CIRCUITS	DIM. A	DIM. B
910X-21-202-XX	4	.100	.19
-203-	6	.200	.29
-204-	8	.300	.39
-205-	10	.400	.49
-206-	12	.500	.59
-207-	14	.600	.69
-208-	16	.700	.79
-209-	18	.800	.89
-210-	20	.900	.99
-211-	22	1.000	1.09
-212-	24	1.100	1.19
-213-	26	1.200	1.29
-214-	28	1.300	1.39
-215-	30	1.400	1.49
-216-	32	1.500	1.59
-217-	34	1.600	1.69
-218-	36	1.700	1.79
-219-	38	1.800	1.89
-220-	40	1.900	1.99
-221-	42	2.000	2.09
-222-	44	2.100	2.19
-223-	46	2.200	2.29
-224-	48	2.300	2.39
-225-	50	2.400	2.49
-226-	52	2.500	2.59
-227-	54	2.600	2.69
-228-	56	2.700	2.79
-229-	58	2.800	2.89
-230-	60	2.900	2.99
-231-	62	3.000	3.09
-232-	64	3.100	3.19
-233-	66	3.200	3.29
-234-	68	3.300	3.39
-235-	70	3.400	3.49
-236-	72	3.500	3.59
-237-	74	3.600	3.69
-238-	76	3.700	3.79
-239-	78	3.800	3.89
910X-21-240-XX	80	3.900	3.99

