

To our customers,

Old Company Name in Catalogs and Other Documents

On April 1st, 2010, NEC Electronics Corporation merged with Renesas Technology Corporation, and Renesas Electronics Corporation took over all the business of both companies. Therefore, although the old company name remains in this document, it is a valid Renesas Electronics document. We appreciate your understanding.

Renesas Electronics website: <http://www.renesas.com>

April 1st, 2010
Renesas Electronics Corporation

Issued by: Renesas Electronics Corporation (<http://www.renesas.com>)

Send any inquiries to <http://www.renesas.com/inquiry>.

Notice

1. All information included in this document is current as of the date this document is issued. Such information, however, is subject to change without any prior notice. Before purchasing or using any Renesas Electronics products listed herein, please confirm the latest product information with a Renesas Electronics sales office. Also, please pay regular and careful attention to additional and different information to be disclosed by Renesas Electronics such as that disclosed through our website.
2. Renesas Electronics does not assume any liability for infringement of patents, copyrights, or other intellectual property rights of third parties by or arising from the use of Renesas Electronics products or technical information described in this document. No license, express, implied or otherwise, is granted hereby under any patents, copyrights or other intellectual property rights of Renesas Electronics or others.
3. You should not alter, modify, copy, or otherwise misappropriate any Renesas Electronics product, whether in whole or in part.
4. Descriptions of circuits, software and other related information in this document are provided only to illustrate the operation of semiconductor products and application examples. You are fully responsible for the incorporation of these circuits, software, and information in the design of your equipment. Renesas Electronics assumes no responsibility for any losses incurred by you or third parties arising from the use of these circuits, software, or information.
5. When exporting the products or technology described in this document, you should comply with the applicable export control laws and regulations and follow the procedures required by such laws and regulations. You should not use Renesas Electronics products or the technology described in this document for any purpose relating to military applications or use by the military, including but not limited to the development of weapons of mass destruction. Renesas Electronics products and technology may not be used for or incorporated into any products or systems whose manufacture, use, or sale is prohibited under any applicable domestic or foreign laws or regulations.
6. Renesas Electronics has used reasonable care in preparing the information included in this document, but Renesas Electronics does not warrant that such information is error free. Renesas Electronics assumes no liability whatsoever for any damages incurred by you resulting from errors in or omissions from the information included herein.
7. Renesas Electronics products are classified according to the following three quality grades: “Standard”, “High Quality”, and “Specific”. The recommended applications for each Renesas Electronics product depends on the product’s quality grade, as indicated below. You must check the quality grade of each Renesas Electronics product before using it in a particular application. You may not use any Renesas Electronics product for any application categorized as “Specific” without the prior written consent of Renesas Electronics. Further, you may not use any Renesas Electronics product for any application for which it is not intended without the prior written consent of Renesas Electronics. Renesas Electronics shall not be in any way liable for any damages or losses incurred by you or third parties arising from the use of any Renesas Electronics product for an application categorized as “Specific” or for which the product is not intended where you have failed to obtain the prior written consent of Renesas Electronics. The quality grade of each Renesas Electronics product is “Standard” unless otherwise expressly specified in a Renesas Electronics data sheets or data books, etc.
 - “Standard”: Computers; office equipment; communications equipment; test and measurement equipment; audio and visual equipment; home electronic appliances; machine tools; personal electronic equipment; and industrial robots.
 - “High Quality”: Transportation equipment (automobiles, trains, ships, etc.); traffic control systems; anti-disaster systems; anti-crime systems; safety equipment; and medical equipment not specifically designed for life support.
 - “Specific”: Aircraft; aerospace equipment; submersible repeaters; nuclear reactor control systems; medical equipment or systems for life support (e.g. artificial life support devices or systems), surgical implantations, or healthcare intervention (e.g. excision, etc.), and any other applications or purposes that pose a direct threat to human life.
8. You should use the Renesas Electronics products described in this document within the range specified by Renesas Electronics, especially with respect to the maximum rating, operating supply voltage range, movement power voltage range, heat radiation characteristics, installation and other product characteristics. Renesas Electronics shall have no liability for malfunctions or damages arising out of the use of Renesas Electronics products beyond such specified ranges.
9. Although Renesas Electronics endeavors to improve the quality and reliability of its products, semiconductor products have specific characteristics such as the occurrence of failure at a certain rate and malfunctions under certain use conditions. Further, Renesas Electronics products are not subject to radiation resistance design. Please be sure to implement safety measures to guard them against the possibility of physical injury, and injury or damage caused by fire in the event of the failure of a Renesas Electronics product, such as safety design for hardware and software including but not limited to redundancy, fire control and malfunction prevention, appropriate treatment for aging degradation or any other appropriate measures. Because the evaluation of microcomputer software alone is very difficult, please evaluate the safety of the final products or system manufactured by you.
10. Please contact a Renesas Electronics sales office for details as to environmental matters such as the environmental compatibility of each Renesas Electronics product. Please use Renesas Electronics products in compliance with all applicable laws and regulations that regulate the inclusion or use of controlled substances, including without limitation, the EU RoHS Directive. Renesas Electronics assumes no liability for damages or losses occurring as a result of your noncompliance with applicable laws and regulations.
11. This document may not be reproduced or duplicated, in any form, in whole or in part, without prior written consent of Renesas Electronics.
12. Please contact a Renesas Electronics sales office if you have any questions regarding the information contained in this document or Renesas Electronics products, or if you have any other inquiries.

(Note 1) “Renesas Electronics” as used in this document means Renesas Electronics Corporation and also includes its majority-owned subsidiaries.

(Note 2) “Renesas Electronics product(s)” means any product developed or manufactured by or for Renesas Electronics.

HD74LVC4245A

Octal Bus Transceiver and 3.3 V to 5 V shifters with 3-state Outputs

REJ03D0378-0101

Rev.1.01

Apr. 13, 2005

Description

The HD74LVC4245A has eight bus transceivers with three state outputs in a 24 pin package. When (DIR) is high, data flows from the A inputs to the B outputs, and when (DIR) is low, data flows from the B inputs to the A outputs. A and B bus are separated by making enable input (\overline{OE}) high level. And this product has two terminals (V_{CCA} , V_{CCB}), V_{CCA} (5V) is connected with control input and A bus side, V_{CCB} (3.3V) connected with B bus side. V_{CCA} and V_{CCB} are isolated. This allows for translation from a 3.3 V to a 5 V environment, and vice versa. Low voltage and high-speed operation is suitable at the battery drive product (note type personal computer) and low power consumption extends the life of a battery for long time operation.

Features

- This product function as level shift transceiver that change V_{CCA} input level to V_{CCB} output level, V_{CCB} input level to V_{CCA} output level by providing different supply voltage to V_{CCA} and V_{CCB} .
- This product is able to the power management: Turn on and off the supply on V_{CCB} side with providing the supply of V_{CCA} . (Enable input (\overline{OE}): High level)
- $V_{CCA} = 4.5\text{ V to }5.5\text{ V}$, $V_{CCB} = 2.7\text{ V to }3.6\text{ V}$
- All control input V_I (max) = 5.5 V (@ $V_{CCA} = 0\text{ V to }5.5\text{ V}$)
- All A bus side input outputs V_{IO} (max) = 5.5 V (@ $V_{CCA} = 0\text{ V}$ or output off state)
- All B bus side input outputs V_{IO} (max) = 3.6 V (@ $V_{CCB} = 0\text{ V}$ or output off state)
- High output current
 A bus side : $\pm 24\text{ mA}$ (@ $V_{CCA} = 4.5\text{ V to }5.5\text{ V}$)
 B bus side : $\pm 12\text{ mA}$ (@ $V_{CCB} = 2.7\text{ V}$)
 $\pm 24\text{ mA}$ (@ $V_{CCB} = 3.0\text{ V to }3.6\text{ V}$)
- Ordering Information

Part Name	Package Type	Package Code (Previous Code)	Package Abbreviation	Taping Abbreviation (Quantity)
HD74LVC4245ATEL	TSSOP-24 pin	PTSP0024JB-A (TTP-24DBV)	T	EL (1,000 pcs/reel)

Function Table

Inputs		Operation
\overline{OE}	DIR	
L	L	B data to A bus
L	H	A data to B bus
H	X	Z

H: High level

L: Low level

X: Immaterial

Z: High impedance

Pin Arrangement

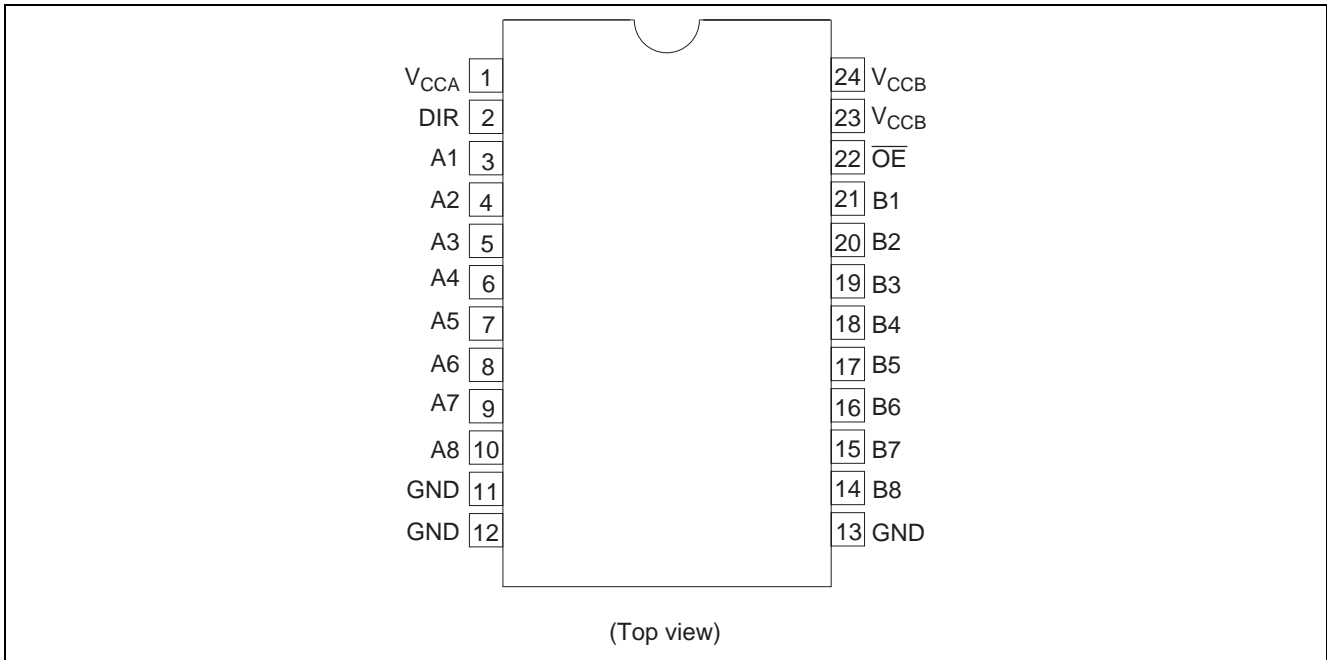

Absolute Maximum Ratings

(1) For V_{CCA}

Item	Symbol	Ratings	Unit	Conditions
Supply voltage	V_{CCA}	-0.5 to 6.0	V	
Input voltage ¹	V_I	-0.5 to 6.0	V	DIR, \overline{OE}
Input / output voltage	$V_{I/O}$	-0.5 to $V_{CCA}+0.5$	V	A port output "H" or "L"
		-0.5 to 6.0		A port output "Z" or V_{CCA} : OFF
Input diode current	I_{IK}	-50	mA	$V_I < 0$
Output diode current	I_{OK}	-50	mA	$V_O < 0$
		50		$V_O > V_{CCA}+0.5$
Output current	I_O	± 50	mA	
V_{CCA} , GND current	I_{CCA} OR I_{GND}	100	mA	
Maximum power dissipation at $T_a = 25^\circ\text{C}$ (in still air) ²	P_T	862	mW	TSSOP
Storage temperature	T_{stg}	-65 to 150	$^\circ\text{C}$	

(2) For V_{CCB}

Item	Symbol	Ratings	Unit	Conditions
Supply voltage	V_{CCB}	-0.5 to 4.6	V	
Input / output voltage ¹	$V_{I/O}$	-0.5 to $V_{CCB}+0.5$	V	B port output "H" or "L"
		-0.5 to 4.6		B port output "Z" or V_{CCB} : OFF
Input diode current	I_{IK}	-50	mA	$V_I < 0$
Output diode current	I_{OK}	-50	mA	$V_O < 0$
		50		$V_O > V_{CCB}+0.5$
Output current	I_O	± 50	mA	
V_{CCB} , GND current	I_{CCB} OR I_{GND}	100	mA	
Maximum power dissipation at $T_a = 25^\circ\text{C}$ (in still air) ²	P_T	862	mW	TSSOP
Storage temperature	T_{stg}	-65 to 150	$^\circ\text{C}$	

Notes: The absolute maximum ratings are values, which must not individually be exceeded, and furthermore, no two of which may be realized at the same time.

1. The input and output voltage ratings may be exceeded even if the input and output clamp-current ratings are observed.
2. The maximum package power dissipation was calculated using a junction temperature of 150 $^\circ\text{C}$.

Recommended Operating Conditions

(1) For V_{CCA}

Item	Symbol	Ratings	Unit	Conditions
Supply voltage	V_{CCA}	4.5 to 5.5	V	
Input / output voltage	V_I	0 to 5.5	V	DIR, \overline{OE}
	$V_{I/O}$	0 to V_{CCA}		A port output "H" or "L"
		0 to 5.5		A port output "Z" or V_{CCA} : OFF
Output current	I_{OH}	-24	mA	
	I_{OL}	24		
Input transition rise or fall time	$\Delta t / \Delta v$	10	ns / V	
Operating temperature	T_a	-40 to 85	°C	

(2) For V_{CCB}

Item	Symbol	Ratings	Unit	Conditions
Supply voltage	V_{CCB}	2.7 to 3.6	V	
Input / output voltage	$V_{I/O}$	0 to V_{CCB}	V	B port output "H" or "L"
		0 to 3.6		B port output "Z" or V_{CCB} : OFF
Output current	I_{OH}	-12	mA	$V_{CCB} = 2.7\text{ V}$
		-24		$V_{CCB} = 3.0\text{ to }3.6\text{ V}$
	I_{OL}	12		$V_{CCB} = 2.7\text{ V}$
		24		$V_{CCB} = 3.0\text{ to }3.6\text{ V}$
Input transition rise or fall time	$\Delta t / \Delta v$	10	ns / V	
Operating temperature	T_a	-40 to 85	°C	

Note: Unused or floating inputs must be held high or low.

Block Diagram

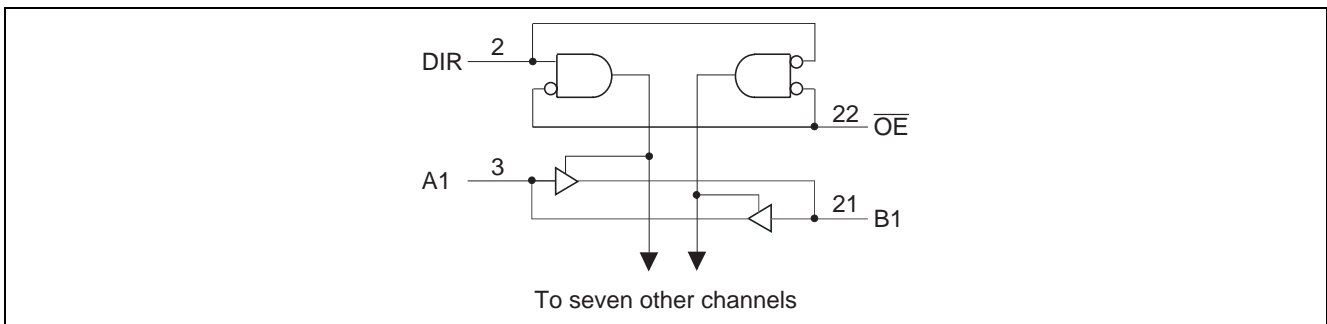

Electrical Characteristics

(Ta = -40 to 85°C)

Item	Symbol	V _{CCA} (V)	V _{CCB} (V)	Min	Max	Unit	Test Conditions
Input voltage	V _{IH}	4.5 to 5.5	2.7 to 3.6	2	—	V	
	V _{IL}	4.5 to 5.5	2.7 to 3.6	—	0.8		
Output voltage	V _{OHA}	4.5 to 5.5	2.7 to 3.6	V _{CCA} -0.2	—	V	I _{OH} = -100 μA
		4.5	2.7 to 3.6	3.7	—		I _{OH} = -24 mA
		5.5	2.7 to 3.6	4.7	—		
	V _{OHB}	4.5 to 5.5	2.7 to 3.6	V _{CCB} -0.2	—	V	I _{OH} = -100 μA
		4.5 to 5.5	2.7	2.2	—		I _{OH} = -12 mA
		4.5 to 5.5	3.0	2.4	—		
		4.5 to 5.5	3.0	2	—		I _{OH} = -24 mA
	V _{OLA}	4.5 to 5.5	2.7 to 3.6	—	0.2	V	I _{OL} = 100 μA
		4.5	2.7 to 3.6	—	0.55		I _{OL} = 24 mA
		5.5	2.7 to 3.6	—	0.55		
	V _{OLB}	4.5 to 5.5	2.7 to 3.6	—	0.2	V	I _{OL} = 100 μA
		4.5 to 5.5	2.7	—	0.4		I _{OL} = 12 mA
4.5 to 5.5		3.0	—	0.55	I _{OL} = 24 mA		
Input current	I _{IN}	5.5	2.7 to 3.6	—	±1	μA	Control input
Off state output current	I _{OZA}	5.5	2.7 to 3.6	—	±5	μA	A port, V _O = V _{CCA} or GND
	I _{OZB}	4.5 to 5.5	3.6	—	±5		B port, V _O = V _{CCB} or GND
Output leak current	I _{OFF}	0	0	—	20	μA	A port, V _{I/O} = 5.5 V B port, V _{I/O} = 3.6 V
Quiescent supply current	I _{CCA}	5.5	2.7 to 3.6	—	80	μA	B to A, control input = V _{CCA} or GND Bn = V _{CCB} or GND, I _O (A port) = 0
	I _{CCB}	4.5 to 5.5	3.6	—	50	μA	A to B, control input = V _{CCA} or GND An = V _{CCA} or GND, I _O (B port) = 0
Increase in I _{CC} per input ¹	ΔI _{CCA}	5.5	2.7 to 3.6	—	1.5	mA	A port or Control input, One input at 3.4 V, Other input at V _{CCA} at GND
	ΔI _{CCB}	4.5 to 5.5	2.7 to 3.6	—	0.5	mA	B port, One input at V _{CCB} -0.6V, Other input at V _{CCB} at GND

Notes: For condition shown as Min or Max, use the appropriate values under recommended operating conditions.

1. This is the increase in supply current for each input that is at the specified TTL voltage level rather than V_{CC} or GND.

Capacitance

(Ta = 25°C)

Item	Symbol	V _{CCA} (V)	V _{CCB} (V)	Min	Typ	Max	Unit	Test Conditions
Control Input capacitance	C _{IN}	5	3.3	—	5	—	pF	V _I = V _{CCA} or GND
Input/output capacitance	C _{I/O}	5	3.3	—	11	—	pF	A port, V _I = V _{CCA} or GND, B port, V _I = V _{CCB} or GND

Switching Characteristics

(Ta = -40 to 85°C), V_{CCA} = 5.0±0.5 V, V_{CCB} = 2.7 V to 3.6 V)

Item	Symbol	Min	Typ	Max	Unit	Test conditions	From(Input)	To(Output)
Propagation delay time	t _{PLH}	1	—	6.7	ns	C _L = 50 pF R _L = 500 Ω	A	B
	t _{PHL}	1	—	6.3				
	t _{PLH}	1	—	5			B	A
	t _{PHL}	1	—	6.1				
Output enable time	t _{ZH}	1	—	8.1	ns	C _L = 50 pF R _L = 500 Ω	OE	A
	t _{ZL}	1	—	9				
	t _{ZH}	1	—	9.8			OE	B
	t _{ZL}	1	—	8.8				
Output disable time	t _{HZ}	1	—	5.8	ns	C _L = 50 pF R _L = 500 Ω	OE	A
	t _{LZ}	1	—	7				
	t _{HZ}	1	—	7.8			OE	B
	t _{LZ}	1	—	7.7				

Operating Characteristics

Item	Symbol	V _{CCA} (V)	V _{CCB} (V)	Min	Typ	Max	Unit	Test Conditions
Power dissipation capacitance	C _{PD}	5.0	3.0	—	39.5	—	pF	f = 10 MHz, C _L = 0

Power-up considerations

Level-translation devices offer an opportunity for successful mixed-voltage signal design.

A proper power-up sequence always should be followed to avoid excessive supply current, bus contention, oscillations, or other anomalies caused by improperly biased device pins.

Take these precautions to guard against such power-up problems.

1. Connect ground before any supply voltage is applied.
2. Next, power up the control side of the device.
(Power up of V_{CCA} is first. Next power up is V_{CCB}.)
3. Tie OE to V_{CCA} with a pullup resistor so that it ramps with V_{CCA}.
4. Depending on the direction of the data path, DIR can be high or low.

If DIR high is needed (A data to B bus), ramp it with V_{CCA}. Otherwise, keep DIR low.

Test Circuit

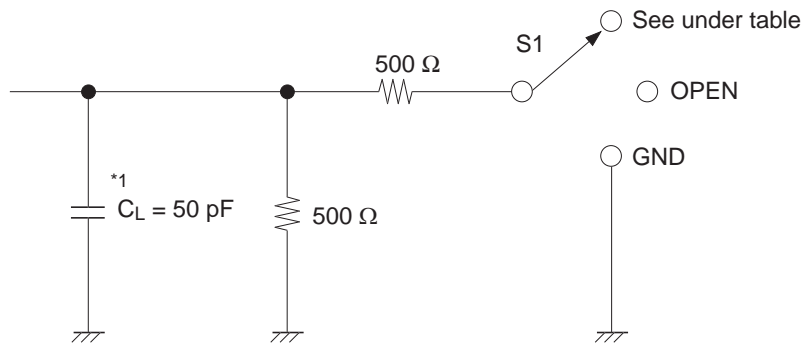

Load circuit for outputs

Symbol	S1	
	$V_{CCA} = 5 \pm 0.5 \text{ V}$ $V_{CCB} = 2.7 \text{ to } 3.6 \text{ V}$	
	A/ \overline{OE} to B	B/ \overline{OE} to A
t_{PLH} / t_{PHL}	OPEN	OPEN
t_{ZH} / t_{HZ}	GND	GND
t_{ZL} / t_{LZ}	6 V	$2 \times V_{CCA}$

Note: 1. C_L includes probe and jig capacitance.

Waveforms – 1

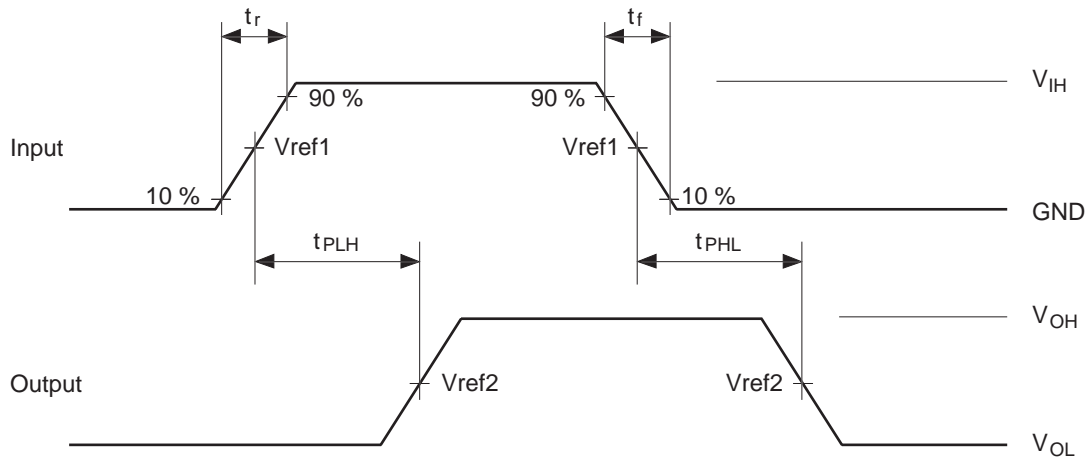

Symbol	$V_{CCA} = 5 \pm 0.5 \text{ V}$ $V_{CCB} = 2.7 \text{ to } 3.6 \text{ V}$	
	A to B	B to A
V_{IH}	3.0 V	2.7 V
Vref1	1.5 V	1.5 V
Vref2	1.5 V	$1/2 V_{CCA}$

Waveforms – 2

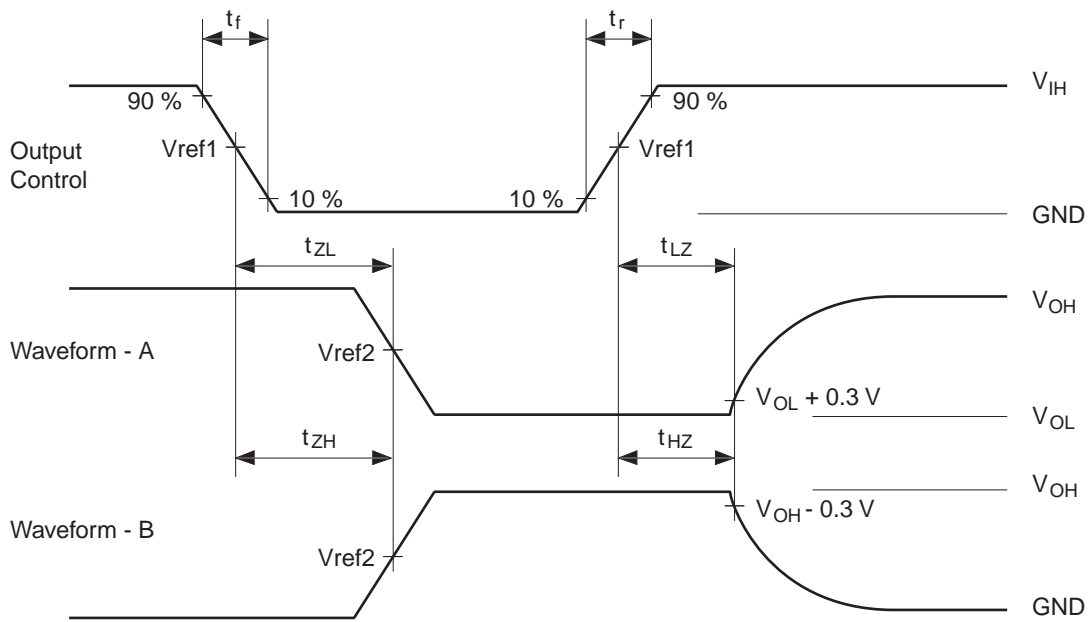

Symbol	$V_{CCA} = 5 \pm 0.5 V$ $V_{CCB} = 2.7 \text{ to } 3.6 V$	
	\overline{OE} to B	\overline{OE} to A
V_{IH}	3.0 V	3.0 V
V_{ref1}	1.5 V	1.5 V
V_{ref2}	1.5 V	$1/2 V_{CCA}$

- Notes:
1. All input pulses are supplied by generators having the following characteristics :
 $PRR \leq 10 \text{ MHz}$, $Z_O = 50 \Omega$, $t_r \leq 2.5 \text{ ns}$, $t_f \leq 2.5 \text{ ns}$.
 2. Waveform - A is for an output with internal conditions such that the output is low except when disabled by the output control.
 3. Waveform - B is for an output with internal conditions such that the output is high except when disabled by the output control.
 4. The output are measured one at a time with one transition per measurement.

Package Dimensions

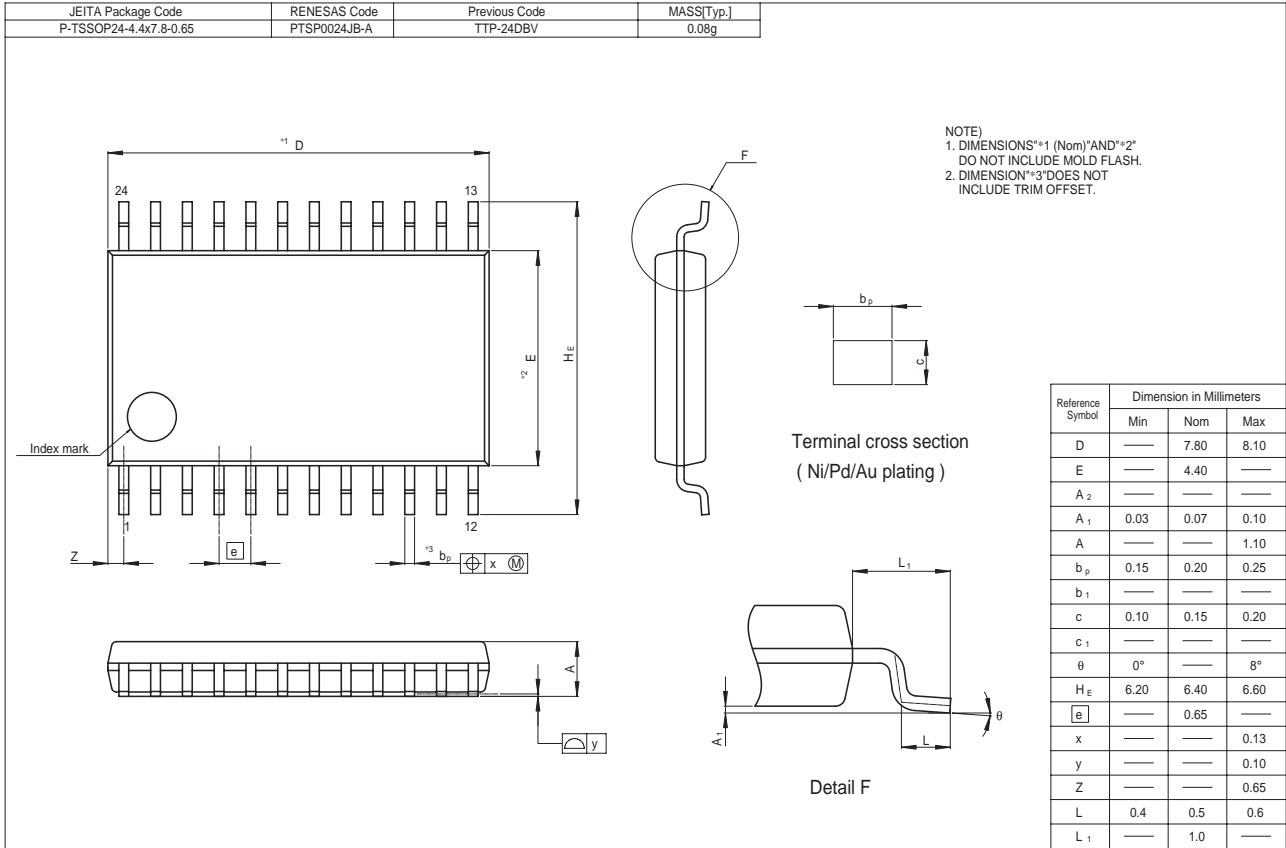

RENESAS Technology Corp. Sales Strategic Planning Div. Nippon Bldg., 2-6-2, Ohte-machi, Chiyoda-ku, Tokyo 100-0004, Japan

Keep safety first in your circuit designs!

1. Renesas Technology Corp. puts the maximum effort into making semiconductor products better and more reliable, but there is always the possibility that trouble may occur with them. Trouble with semiconductors may lead to personal injury, fire or property damage.
Remember to give due consideration to safety when making your circuit designs, with appropriate measures such as (i) placement of substitutive, auxiliary circuits, (ii) use of nonflammable material or (iii) prevention against any malfunction or mishap.

Notes regarding these materials

1. These materials are intended as a reference to assist our customers in the selection of the Renesas Technology Corp. product best suited to the customer's application; they do not convey any license under any intellectual property rights, or any other rights, belonging to Renesas Technology Corp. or a third party.
2. Renesas Technology Corp. assumes no responsibility for any damage, or infringement of any third-party's rights, originating in the use of any product data, diagrams, charts, programs, algorithms, or circuit application examples contained in these materials.
3. All information contained in these materials, including product data, diagrams, charts, programs and algorithms represents information on products at the time of publication of these materials, and are subject to change by Renesas Technology Corp. without notice due to product improvements or other reasons. It is therefore recommended that customers contact Renesas Technology Corp. or an authorized Renesas Technology Corp. product distributor for the latest product information before purchasing a product listed herein.
The information described here may contain technical inaccuracies or typographical errors.
Renesas Technology Corp. assumes no responsibility for any damage, liability, or other loss rising from these inaccuracies or errors.
Please also pay attention to information published by Renesas Technology Corp. by various means, including the Renesas Technology Corp. Semiconductor home page (<http://www.renesas.com>).
4. When using any or all of the information contained in these materials, including product data, diagrams, charts, programs, and algorithms, please be sure to evaluate all information as a total system before making a final decision on the applicability of the information and products. Renesas Technology Corp. assumes no responsibility for any damage, liability or other loss resulting from the information contained herein.
5. Renesas Technology Corp. semiconductors are not designed or manufactured for use in a device or system that is used under circumstances in which human life is potentially at stake. Please contact Renesas Technology Corp. or an authorized Renesas Technology Corp. product distributor when considering the use of a product contained herein for any specific purposes, such as apparatus or systems for transportation, vehicular, medical, aerospace, nuclear, or undersea repeater use.
6. The prior written approval of Renesas Technology Corp. is necessary to reprint or reproduce in whole or in part these materials.
7. If these products or technologies are subject to the Japanese export control restrictions, they must be exported under a license from the Japanese government and cannot be imported into a country other than the approved destination.
Any diversion or reexport contrary to the export control laws and regulations of Japan and/or the country of destination is prohibited.
8. Please contact Renesas Technology Corp. for further details on these materials or the products contained therein.



RENESAS SALES OFFICES

<http://www.renesas.com>

Refer to "<http://www.renesas.com/en/network>" for the latest and detailed information.

Renesas Technology America, Inc.

450 Holger Way, San Jose, CA 95134-1368, U.S.A
Tel: <1> (408) 382-7500, Fax: <1> (408) 382-7501

Renesas Technology Europe Limited

Dukes Meadow, Millboard Road, Bourne End, Buckinghamshire, SL8 5FH, U.K.
Tel: <44> (1628) 585-100, Fax: <44> (1628) 585-900

Renesas Technology Hong Kong Ltd.

7th Floor, North Tower, World Finance Centre, Harbour City, 1 Canton Road, Tsimshatsui, Kowloon, Hong Kong
Tel: <852> 2265-6688, Fax: <852> 2730-6071

Renesas Technology Taiwan Co., Ltd.

10th Floor, No.99, Fushing North Road, Taipei, Taiwan
Tel: <886> (2) 2715-2888, Fax: <886> (2) 2713-2999

Renesas Technology (Shanghai) Co., Ltd.

Unit2607 Ruijing Building, No.205 Maoming Road (S), Shanghai 200020, China
Tel: <86> (21) 6472-1001, Fax: <86> (21) 6415-2952

Renesas Technology Singapore Pte. Ltd.

1 Harbour Front Avenue, #06-10, Keppel Bay Tower, Singapore 098632
Tel: <65> 6213-0200, Fax: <65> 6278-8001