

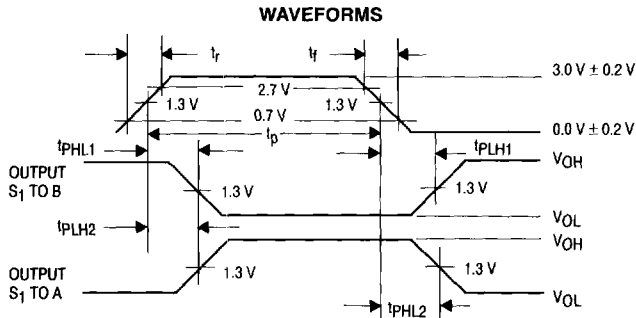

Quad 2-Input Exclusive NOR Gate

ELECTRICALLY TESTED PER:
MIL-M-38510/30303

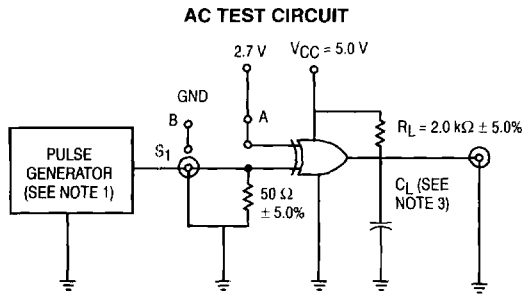
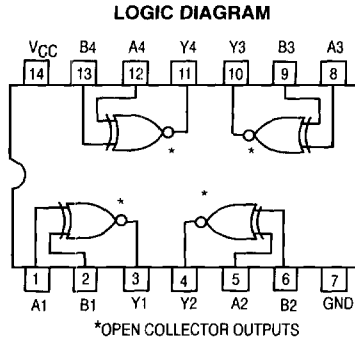

NOTES:

1. The generator has the following characteristics: $t_r \leq 6.0$ ns, $t_f = 15$ ns; PRR ≤ 1.0 MHz, $t_p = 0.5$ μ s, $Z_{OUT} = 50 \Omega$.
2. Each gate tested separately.
3. $C_L = 50$ pF $\pm 10\%$ including scope probe, wiring and stray capacitance, without package in test fixture.
4. Voltage measurements are to be made with respect to network ground terminal.
5. $R_L = 2.0$ k Ω $\pm 5.0\%$.

Military 54LS266



AVAILABLE AS:

- 1) JAN: JM38510/30303BXA
- 2) SMD: N/A
- 3) 883: 54LS266/BXAJC

X = CASE OUTLINE AS FOLLOWS:
PACKAGE: CERDIP: C
CERFLAT: D
LCC: 2

THE LETTER "M" APPEARS BEFORE THE / ON LCC.

PIN ASSIGNMENTS

FUNCT.	DIL 632-08	FLATS 717-04	LCC 756A-02	BURN-IN (COND. A)
A1	1	1	2	VCC
B1	2	2	3	VCC
Y1	3	3	4	VCC
Y2	4	4	6	VCC
A2	5	5	8	VCC
B2	6	6	9	VCC
GND	7	7	10	GND
A3	8	8	12	VCC
B3	9	9	13	VCC
Y3	10	10	14	VCC
Y4	11	11	16	VCC
A4	12	12	18	VCC
B4	13	13	19	VCC
VCC	14	14	20	VCC

BURN-IN CONDITIONS:
 $V_{CC} = 5.0$ V MIN/ 6.0 V MAX

TRUTH TABLE

Inputs		Output
A	B	Z
0	0	1
0	1	0
1	0	0
1	1	1

54LS266

Symbol	Parameter	Limits						Unit	Test Condition (Unless Otherwise Specified)
		+ 25°C		+ 125°C		- 55°C			
		Subgroup 1		Subgroup 2		Subgroup 3			
		Min	Max	Min	Max	Min	Max		
V _{OL}	Logical "0" Output Voltage		0.4		0.4		0.4	V	V _{CC} = 4.5 V, I _{OL} = 4.0 mA, V _{IL} = 0.7 V, other input = 2.0 V, or per truth table.
V _{IC}	Input Clamping Voltage		- 1.5					V	V _{CC} = 4.5 V, I _{IN} = - 18 mA, other input is open.
I _{CEX}	Open Collector Input Current		100		100		100	μA	V _{CC} = 4.5 V, V _{OUT} = 5.5 V, V _{IL} = 0.7 V, other input = 0.7 V, or per truth table.
I _{IH}	Logical "1" Input Current		40		40		40	μA	V _{CC} = 5.5 V, V _{IH} = 2.7 V, other input = GND.
I _{IHH}	Logical "1" Input Current		200		200		200	μA	V _{CC} = 5.5 V, V _{IHH} = 5.5 V, other input = GND.
I _{IL}	Logical "0" Input Current	- 300	- 760	- 300	- 760	- 300	- 760	μA	V _{CC} = 5.5 V, V _{IN} = 0.4 V, other input = 5.5 V.
I _{CC}	Power Supply Current		13		13		13	mA	V _{CC} = 5.5 V, V _{IN} = 4.5 V, other input = GND.
V _{IH}	Logical "1" Input Voltage	2.0		2.0		2.0		V	V _{CC} = 4.5 V.
V _{IL}	Logical "0" Input Voltage		0.7		0.7		0.7	V	V _{CC} = 4.5 V.
	Functional Tests	Subgroup 7		Subgroup 8A		Subgroup 8B			per Truth Table with V _{CC} = 5.0 V, V _{INL} = 0.4 V, and V _{INH} = 2.5 V.

Symbol	Parameter	Limits						Unit	Test Condition (Unless Otherwise Specified)
		+ 25°C		+ 125°C		- 55°C			
		Subgroup 9		Subgroup 10		Subgroup 11			
		Min	Max	Min	Max	Min	Max		
t _{PHL1} t _{PHL1}	Propagation Delay /Data-Output Output High-Low	2.0	40	2.0	45	2.0	45	ns	V _{CC} = 5.0 V, C _L = 50 pF, R _L = 2.0 kΩ V _{CC} = 5.0 V, C _L = 15 pF, R _L = 2.0 kΩ
t _{PLH1} t _{PLH1}	Propagation Delay /Data-Output Output Low-High	2.0	45	2.0	56	2.0	56	ns	V _{CC} = 5.0 V, C _L = 50 pF, R _L = 2.0 kΩ V _{CC} = 5.0 V, C _L = 15 pF, R _L = 2.0 kΩ
t _{PHL2} t _{PHL2}	Propagation Delay /Data-Output Output Low-High	2.0	40	2.0	45	2.0	45	ns	V _{CC} = 5.0 V, C _L = 50 pF, R _L = 2.0 kΩ V _{CC} = 5.0 V, C _L = 15 pF, R _L = 2.0 kΩ
t _{PLH2} t _{PLH2}	Propagation Delay /Data-Output Output Low-High	2.0	45	2.0	56	2.0	56	ns	V _{CC} = 5.0 V, C _L = 50 pF, R _L = 2.0 kΩ V _{CC} = 5.0 V, C _L = 15 pF, R _L = 2.0 kΩ

NOTE:

1. The limits specified for C_L = 15 pF are guaranteed but not tested.