

信昌電子陶瓷股份有限公司

Prosperity Dielectrics Co., Ltd.

No. 148, Chang-An Road, Sec 1, Lu-Tsu Shiang, Taoyuan, Taiwan, ROC.

Tel. : 886-3-3224471 Fax : 886-3-3212216

SPECIFICATION FOR APPROVAL

DATE:

CUSTOMER: _____ LIMITED COMPANY

PART NAME: Thick Film Lead Free Chip Resistor

CUSTOMER'S DWG. NO. _____

CUSTOMER'S PART NO. _____

PDC PART NO. FCF Series Approved

DESCRIPTION. _____

RESULT \ ACTION	" √ "	CUSTOMER'S SIGNATURE	NOTE
FULL APPROVED			
CONDITIONAL APPROVED			
REJECTED			

OUR ACTION	SIGNATURE
PREPARED BY	<i>Angel Wu</i>
CHECKED BY	<i>James Tseng</i>
APPROVED BY	<i>Roger Hsu</i>

CUSTOMER SIGNATURE FOR ACCEPTANCE

■ Features

- Suitable for lead free soldering.
- Compatible with wave and reflow soldering
- Anti-sulfurate chip resistors
- RoHS compliant & Halogen Free

■ Applications

- Automotive industry
- Consumer Electronics
- Measurement instrument
- Computer

■ Configuration

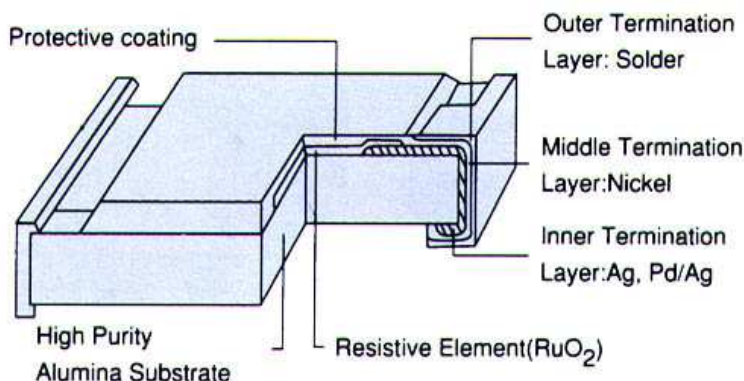

■ Dimensions

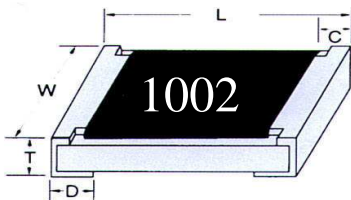

Size	L	W	C	D	T
0402	1.00±0.10	0.50±0.10	0.20±0.20	0.20±0.20	0.35±0.10
0603	1.60±0.10	0.80±0.10	0.30±0.20	0.30±0.20	0.45±0.10
0805	2.00±0.15	1.20±0.15	0.40±0.20	0.40±0.20	0.50±0.10
1206	3.10±0.15	1.60±0.15	0.50±0.25	0.50±0.25	0.55±0.10
2010	5.00±0.20	2.50±0.20	0.60±0.25	0.60±0.25	0.60±0.10
2512	6.30±0.20	3.10±0.20	0.60±0.25	0.60±0.25	0.60±0.15

■ Power Derating Curve

(unit: mm)

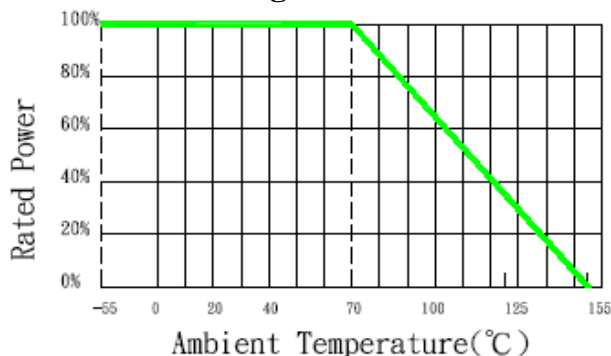

Maximum dissipation in percentage of rated power as a function of the ambient temperature for 0603,0805,1206,2010,2512

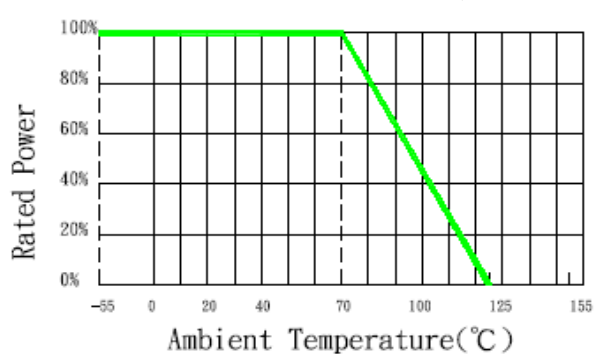

Maximum dissipation in percentage of rated power as a function of the ambient temperature for 0402,

Rating

FCF Series

• LEAD FREE CHIP RESISTORS

Type	Size	Power Rating at 70°C	Max. RCWV	Max. Overload Voltage	Resistance Tolerance (%)	Temperature Coefficient (TCR; ppm/°C)	Resistance Range		Standard Resistance Values
							Min.	Max.	
FCF02	0402	1/16W	50V	100V	±0.1%(B)	±200	10Ω	1MΩ	E-96
					±1%(F)		10Ω	1MΩ	E-96
					±5%(J)		0Ω&1Ω	10MΩ	E-24
FCF03	0603	1/10W	50V	100V	±0.1%(B)	±50	20Ω	510KΩ	E-96
					±0.25%(C)				E-96
					±0.5%(D)				E-96
FCF05	0805	1/8W	150V	300V	±1%(F)	±100	1Ω	10MΩ	E-96
					±1%(F)		1Ω	10MΩ	E-96
FCF06	1206	1/4W	200V	400V	±2%(G)	±200	1Ω	10MΩ	E-24
					±5%(J)		±200	0Ω&1Ω	10MΩ
FCF20	2010	1/2W	200V	400V	±1%(F)	±100	1Ω	10MΩ	E-96
					±5%(J)		±200	0Ω&1Ω	10MΩ
FCF25	2512	1W	200V	400V	±1%(F)	±100	1Ω	10MΩ	E-96
					±5%(J)		±200	0Ω&1Ω	10MΩ

Jumper : ◎ 0402,0603 size maximum resistance $R_{max} < 50m\Omega$ and rated current $I_R \leq 1A$

◎ 0805,1206,1210,2010,2512 size maximum resistance $R_{max} < 50m\Omega$ and rated current $I_R \leq 2A$

1Ω~10Ω: ◎ Temperature Coefficient of Resistance for 0402,0603,0805,1206 = -300 ~ +500

◎ Temperature Coefficient of Resistance for 2010,2512 = ± 300

• LOW RESISTANCE LEAD FREE CHIP RESISTORS

Type	Size	Power Rating at 70°C	Max. RCWV	Max. Overload Voltage	Resistance Tolerance (%)	Temperature Coefficient (TCR; ppm/°C)	Resistance Range		Standard Resistance Values
							Min.	Max.	
FCF03	0603	1/10W	302mV	603mV	±1%(F) ±5%(J)	±300	100mΩ	910mΩ	E-24
FCF05	0805	1/8W	337mV	675mV	±1%(F) ±5%(J)	±300	100mΩ	910mΩ	E-24
						±400	50mΩ	91mΩ	
FCF06	1206	1/4W	477mV	954mV	±1%(F) ±5%(J)	±200	50mΩ	910mΩ	E-24
FCF20	2010	1/2W	675mV	1349mV		±400	40mΩ	47mΩ	
						±600	22mΩ	39mΩ	
						±1000	10mΩ	20mΩ	
FCF25	2512	1W	954mV	1908mV					

■ Soldering Temperature Curve

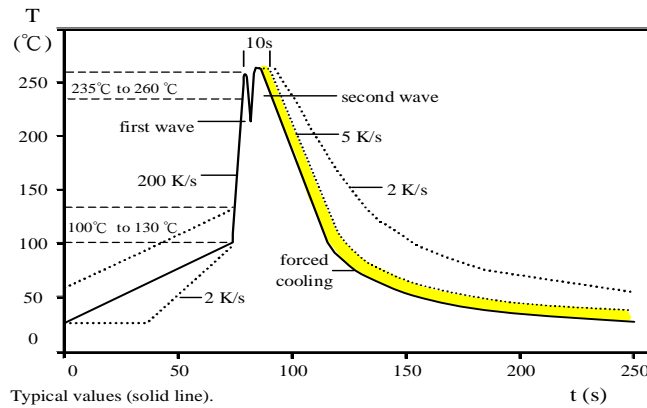

Typical values (solid line).
Process limits (dotted line). **WAVE soldering.**

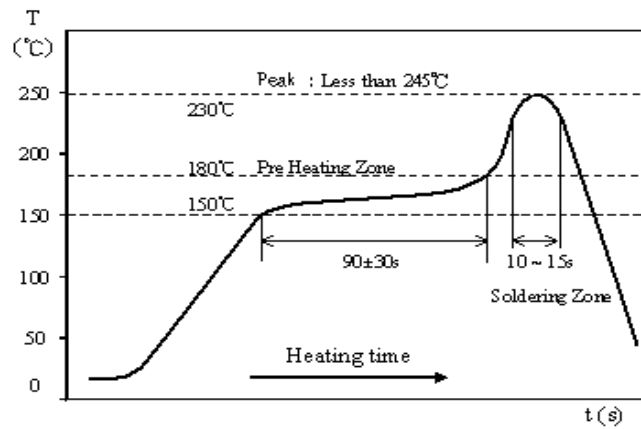

IR Reflow Soldering

■ Part Number

FCF	05	F	T	—	1002	—	W
Type	Size	Tolerance	Packing		GM	TCR	Specialty
FCF	02 : 0402 03 : 0603 05 : 0805 06 : 1206 20 : 2010 25 : 2512	B : ± 0.1% C : ±0.25% D : ± 0.5% F : ± 1% G : ± 2% J : ± 5%	S : Paper tape 1Kpcs T : Paper tape 5Kpcs V : Paper tape 10Kpcs U : Paper tape 15Kpcs W : Paper tape 20Kpcs X : Plastic tape 8Kpcs Y : Plastic tape 16Kpcs		examples: 1002 100*10 ² =10KΩ	<div style="border: 1px solid black; padding: 5px;"> — TCR as page 2 Rating P : 50ppm N:100ppm For 1Ω~10Ω 0402 0603 0805 1206 2010 2512 1% only. </div>	W: anti-sulfurate products
example: FCF05FT-1002-W							

SPECIFICATION

■ Resistance Marking

E - 24 SERIES



4 digit marking for $\pm 1\%$, $\pm 5\%$
E24 ($10\text{m}\Omega \sim 910\text{m}\Omega$)
examples: R100 = $100\text{m}\Omega$
R047 = $47\text{m}\Omega$



3 digit marking for 0603 $\pm 1\%$, $\pm 5\%$
E24 ($100\text{m}\Omega \sim 1\Omega$)
examples: **1R0** = 1Ω
R10 = $100\text{m}\Omega$
R50 = $500\text{m}\Omega$



3 digit marking for $\pm 5\%$ E24
examples: **473** $47 \times 10^3 = 47\text{K}\Omega$
1R5 = 1.5Ω

E - 96 SERIES



4 digit marking for E96
examples: **1542** $154 \times 10^2 = 15\text{K}4\Omega$
22R1 = 22.1Ω



3 digit marking for E96 - 0603
examples: **02C** (Table 1)
 $102 \times 10^2 = 10\text{K}2\Omega$

SPECIFICATION

0603 1% Marking Table (Table 1)

Code	E48	E96	Code	E48	E96	Code	E48	E96	Code	E48	E96
01	100	100	25	178	178	49	316	316	73	562	562
02		102	26		182	50		324	74		576
03	105	105	27	187	187	51	332	332	75	590	590
04		107	28		191	52		340	76		604
05	110	110	29	196	196	53	348	348	77	619	619
06		113	30		200	54		357	78		634
07	115	115	31	205	205	55	365	365	79	649	649
08		118	32		210	56		374	80		665
09	121	121	33	215	215	57	383	383	81	681	681
10		124	34		221	58		392	82		698
11	127	127	35	226	226	59	402	402	83	715	715
12		130	36		232	60		412	84		732
13	133	133	37	237	237	61	422	422	85	750	750
14		137	38		243	62		432	86		768
15	140	140	39	249	249	63	442	442	87	787	787
16		143	40		255	64		453	88		806
17	147	147	41	261	261	65	464	464	89	825	825
18		150	42		267	66		475	90		845
19	154	154	43	274	274	67	487	487	91	866	866
20		158	44		280	68		499	92		887
21	162	162	45	287	287	69	511	511	93	909	909
22		165	46		294	70		523	94		931
23	169	169	47	301	301	71	536	536	95	953	953
24		174	48		309	72		549	96		976

Code	A	B	C	D	E	F	G	H	X	Y	Z
Multiplier	10 ⁰	10 ¹	10 ²	10 ³	10 ⁴	10 ⁵	10 ⁶	10 ⁷	10 ⁻¹	10 ⁻²	10 ⁻³

Standard resistance value

E3	10				22				47								
E6	10		15		22		33		47			68					
E12	10	12	15	18	22	27	33	39	47	56	68	82					
E24	10	11	12	13	15	16	18	20	22	24	27	30	33	36	39	43	47
	51	56	62	68	75	82	91										
E96	100	102	105	107	110	113	115	118	121	124	127	130	133	137	140	143	147
	150	154	158	162	165	169	174	178	182	187	191	196	200	205	210	215	221
	226	232	237	243	249	255	261	267	274	280	287	294	301	309	316	324	332
	340	348	357	365	374	383	392	402	412	422	432	442	453	464	475	487	499
	511	523	536	549	562	576	590	604	619	634	649	665	681	698	715	732	750
	768	787	806	825	845	866	887	909	931	953	976						

SPECIFICATION

■ Tape And Reel Package

- Taping specs are according to EIA RS-481

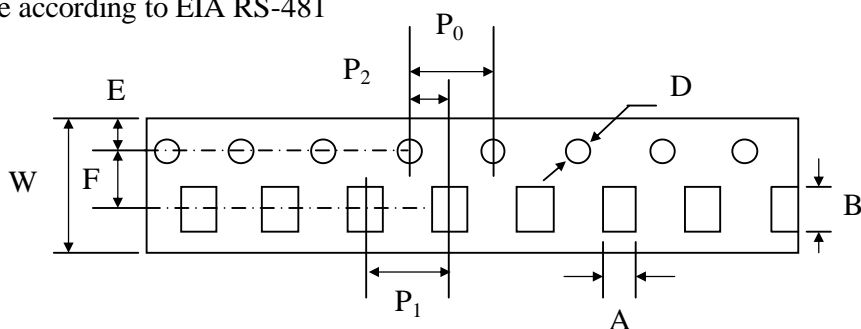

Accumulated dimensional tolerance $40\pm 0.2\text{mm}$

Size	A	B	W	F	E	P1	P2	P0	D
0402	0.70 ± 0.10	1.20 ± 0.10	8.00 ± 0.30	3.50 ± 0.05	1.75 ± 0.10	2.00 ± 0.10	2.00 ± 0.05	4.00 ± 0.10	$1.50+0.10/-0$
0603	1.10 ± 0.20	1.90 ± 0.20	8.00 ± 0.30	3.50 ± 0.05	1.75 ± 0.10	4.00 ± 0.10	2.00 ± 0.05	4.00 ± 0.10	$1.50+0.10/-0$
0805	1.65 ± 0.20	2.40 ± 0.20	8.00 ± 0.30	3.50 ± 0.05	1.75 ± 0.10	4.00 ± 0.10	2.00 ± 0.05	4.00 ± 0.10	$1.50+0.10/-0$
1206	2.00 ± 0.20	3.60 ± 0.20	8.00 ± 0.30	3.50 ± 0.05	1.75 ± 0.10	4.00 ± 0.10	2.00 ± 0.05	4.00 ± 0.10	$1.50+0.10/-0$
2010	2.80 ± 0.20	5.50 ± 0.20	12.00 ± 0.30	5.50 ± 0.05	1.75 ± 0.10	4.00 ± 0.10	2.00 ± 0.05	4.00 ± 0.10	$1.50+0.10/-0$
2512	3.50 ± 0.20	6.70 ± 0.20	12.00 ± 0.30	5.50 ± 0.05	1.75 ± 0.10	4.00 ± 0.10	2.00 ± 0.05	4.00 ± 0.10	$1.50+0.10/-0$

(unit: mm)

SPECIFICATION

- Reel Package

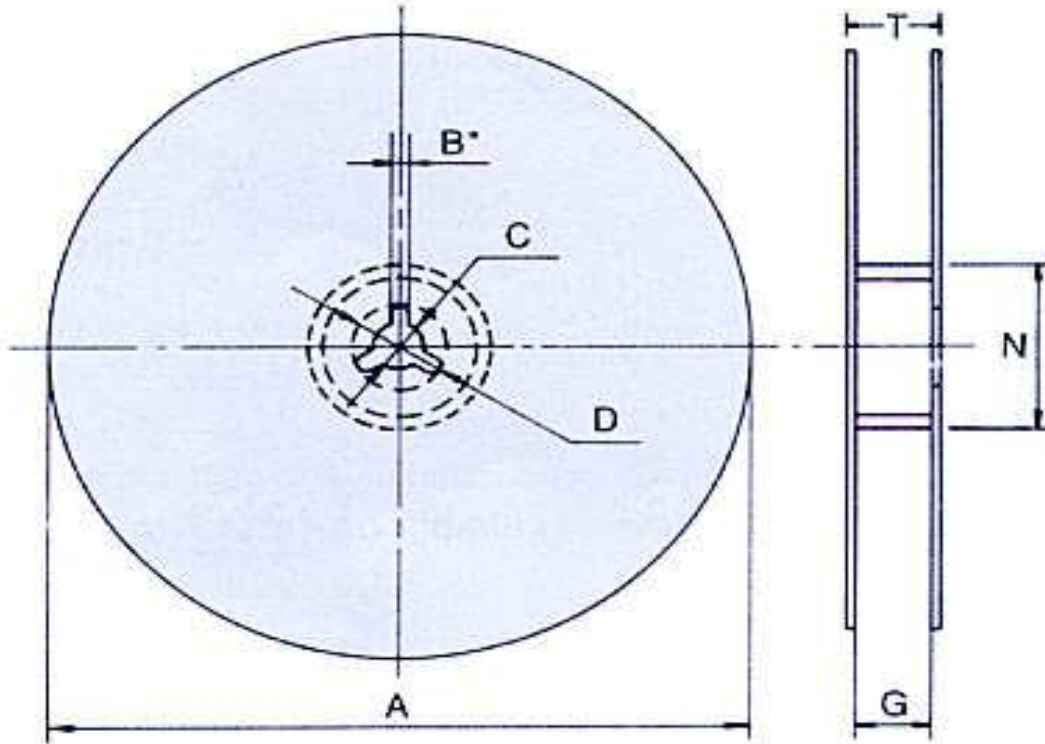

Size	Packaging Q'ty	A	N	C	D	B	G	T
0402	10Kpcs / Reel	178.0±2.0	60.0±0.5	13.0±0.5	20min	2.0±0.5	10.0±1.5	14.9 max.
0603 0805 1206	1Kpcs / Reel	100.0±0.5	52.0±0.5	13.0±0.5	20min	2.0±0.5	9.0±0.5	12.5 max.
	5Kpcs / Reel	178.0±2.0	60.0±0.5	13.0±0.5	20min	2.0±0.5	10.0±1.5	14.9 max.
	10Kpcs / Reel	254.0±2.0	100.0±1.0	13.5±0.5	20min	2.0±0.5	10.0±1.5	14.9 max.
	20Kpcs / Reel	330.0±2.0	100.0±1.0	13.5±0.5	20min	2.0±0.5	10.0±1.5	14.9 max.
2010 2512	4Kpcs / Reel	178.0±2.0	60.0±0.5	13.0±0.5	20min	2.0±0.5	13.8±1.5	16.7 max.
	8Kpcs / Reel	254.0±2.0	100.0±1.0	13.5±0.5	20min	2.0±0.5	13.8±1.5	16.7 max.
	16Kpcs / Reel	330.0±2.0	100.0±1.0	13.5±0.5	20min	2.0±0.5	13.8±1.5	20.0 max.

(unit: mm)

SPECIFICATION

■ FCF $\geq 1 \Omega$ Specification And Test Methods

ITEM	SPECIFICATION	TEST METHOD
DC Resistance	J : $\pm 5\%$, G: $\pm 2\%$, F: $\pm 1\%$ D: $\pm 0.5\%$, C: $\pm 0.25\%$, B: $\pm 0.1\%$ Zero ohm Jumper < 50m Ω	IEC 60115-1 / JIS C 5201-1 , Clause 4.5 Measure the resistance value.
Short time Overload	J、G: $\Delta R \leq \pm (2\% + 0.1 \Omega)$ F、D: $\Delta R \leq \pm (1\% + 0.05 \Omega)$ C、B: $\Delta R \leq \pm (0.5\% + 0.05 \Omega)$	IEC 60115-1 / JIS C 5201-1 , Clause 4.13 2.5×Rated voltage or Max. Overload Voltage for 5 sec. measure resistance after 30 minutes
Solderability	Over 95% of termination must be covered with (Sn+Ag+Cu)	IEC 60115-1 / JIS C 5201-1 , Clause 4.17 After immersing flux, dip in the 235 $\pm 2^\circ\text{C}$ molten solder bath for 2 ± 0.5 sec.
Resistance to Solder Heat	J、G: $\Delta R \leq \pm (1\% + 0.1 \Omega)$ F、D、C、B: $\Delta R \leq \pm (0.5\% + 0.05 \Omega)$ No mechanical damage	IEC 60115-1 / JIS C 5201-1 , Clause 4.18 With 260 $\pm 5^\circ\text{C}$ for 10 ± 1 sec.
Temperature Coefficient of Resistance (TCR)	F: $\pm 100 \text{ ppm}/^\circ\text{C}$ J、G: $\pm 200 \text{ ppm}/^\circ\text{C}$ F、D、C、B: $\pm 50 \text{ ppm}/^\circ\text{C}$ (0402 Size F、J、B: $\pm 200 \text{ ppm}/^\circ\text{C}$) (0201 Size F、J: $\pm 300 \text{ ppm}/^\circ\text{C}$)	IEC 60115-1 / JIS C 5201-1 , Clause 4.8 Test temperature : 25 $^\circ\text{C}$ (T1) \rightarrow -55 $^\circ\text{C}$ (T2) 25 $^\circ\text{C}$ (T1) \rightarrow +155 $^\circ\text{C}$ (T2) $\text{TCR (ppm}/^\circ\text{C}) = \frac{R2-R1}{R1} \times \frac{1}{T2-T1} \times 10^6$ T1: 25 $^\circ\text{C}$ T2: Test temperature R1: Resistance at reference temperature (T1) R2: Resistance at test temperature (T2)
Load Life Humidity	J、G: $\Delta R \leq \pm (3\% + 0.1 \Omega)$ F、D: $\Delta R \leq \pm (1\% + 0.05 \Omega)$ C、B: $\Delta R \leq \pm (0.5\% + 0.05 \Omega)$	IEC 60115-1 / JIS C 5201-1 , Clause 4.24 Maintain the temperature of the resistor at 40 $\pm 2^\circ\text{C}$ and 90~95% R.H. with the rated voltage applied. Cycle ON for 1.5 hours and OFF for 0.5 hour for 1000+48/-0 hours. After 1~4 hour, measure the resistance value.
Load Life	J、G: $\Delta R \leq \pm (3\% + 0.1 \Omega)$ F、D: $\Delta R \leq \pm (1\% + 0.05 \Omega)$ C、B: $\Delta R \leq \pm (0.5\% + 0.05 \Omega)$	IEC 60115-1 / JIS C 5201-1 , Clause 4.25 Permanent resistance change after 1000+48/-0 hours (1.5 hours ON , 0.5 hour OFF) at RCWV or Max. Keep the resistor at 70 $\pm 2^\circ\text{C}$ ambient
Temperature Cycle	J、G: $\Delta R \leq \pm (1\% + 0.1 \Omega)$ F、D、C、B: $\Delta R \leq \pm (0.5\% + 0.05 \Omega)$ No mechanical damage	IEC 60115-1 / JIS C 5201-1 , Clause 4.19 Repeat 5 cycles as follows -55 $^\circ\text{C}$ (30 min.) + 25 $^\circ\text{C}$ (2~3 min.) +125 $^\circ\text{C}$ (30 min.) + 25 $^\circ\text{C}$ (2~3 min.) for 0201 55 $^\circ\text{C}$ (30 min.) + 25 $^\circ\text{C}$ (2~3 min.) +155 $^\circ\text{C}$ (30 min.) + 25 $^\circ\text{C}$ (2~3 min.) for others
Insulation Resistance	Between termination and coating must be over 1000M Ω	IEC 60115-1 / JIS C 5201-1 , Clause 4.6 Test voltage: 100 $\pm 15\text{V}$
Bending Strength	J、G: $\Delta R \leq \pm (1\% + 0.1 \Omega)$ F、D、C、B: $\Delta R \leq \pm (0.5\% + 0.05 \Omega)$ No mechanical damage	IEC 60115-1 / JIS C 5201-1 , Clause 4.33 Resistance change after bended on the 90mm PCB. Bend: 3mm for 0402、0603、0805 2mm for 1206、2010、2512
Anti-sulfurate products require	$\Delta R \leq \pm (1\% + 0.1 \Omega)$ No mechanical damage	Test condition: H ₂ S 3ppm 40 $^\circ\text{C}$ RH 90% 1000Hrs

SPECIFICATION

■ FCF < 1Ω Specification And Test Methods

ITEM	SPECIFICATION	TEST METHOD
DC Resistance	J : ±5% , F: ±1%	IEC 60115-1 / JIS C 5201-1 , Clause 4.5 Measure the resistance value.
Short time Overload	J: $\Delta R \leq \pm(2\% + 0.5m\Omega)$ F: $\Delta R \leq \pm(1\% + 0.5m\Omega)$	IEC 60115-1 / JIS C 5201-1 , Clause 4.13 2.5×Rated voltage or Max. Overload Voltage for 5 sec. measure resistance after 30 minutes
Solderability	Over 95% of termination must be covered with solder	IEC 60115-1 / JIS C 5201-1 , Clause 4.17 After immersing flux, dip in the 235±2°C molten solder bath for 2±0.5 sec.
Resistance to Solder Heat	J: $\Delta R \leq \pm(1\% + 0.5m\Omega)$ F: $\Delta R \leq \pm(0.5\% + 0.5m\Omega)$ No mechanical damage	IEC 60115-1 / JIS C 5201-1 , Clause 4.18 With 260±5°C for 10±1 sec.
Temperature Coefficient of Resistance (TCR)	Size : 0603 、 0805 100mΩ ~ 910mΩ : ± 300ppm/°C 50mΩ ~ 91mΩ : ± 400ppm/°C Size : 1210 100mΩ ~ 910mΩ : ± 200ppm/°C Size : 1206 、 2010 、 2512 50mΩ ~ 910mΩ : ± 200ppm/°C 40mΩ ~ 47mΩ : ±400ppm/°C 22mΩ ~ 39mΩ : ±600ppm/°C 10mΩ ~ 20mΩ : ±1000ppm/°C	IEC 60115-1 / JIS C 5201-1 , Clause 4.8 Test temperature : 25°C (T1) → -55°C (T2) 25°C (T1) → +155°C (T2) $TCR (ppm/^\circ C) = \frac{R2-R1}{R1} \times \frac{1}{T2-T1} \times 10^6$ T1: 25°C T2: Test temperature R1: Resistance at reference temperature (T1) R2: Resistance at test temperature (T2)
Load Life Humidity	J: $\Delta R \leq \pm(3\% + 0.5m\Omega)$ F: $\Delta R \leq \pm(1\% + 0.5m\Omega)$	IEC 60115-1 / JIS C 5201-1 , Clause 4.24 Maintain the temperature of the resistor at 40±2°C and 90~95% R.H. with the rated voltage applied. Cycle ON for 1.5 hours and OFF for 0.5 hour for 1000+48/-0 hours. After 1~4 hour, measure the resistance value.
Load Life	J: $\Delta R \leq \pm(3\% + 0.5m\Omega)$ F: $\Delta R \leq \pm(1\% + 0.5m\Omega)$	IEC 60115-1 / JIS C 5201-1 , Clause 4.25 Permanent resistance change after 1000+48/-0 hours (1.5 hours ON , 0.5 hour OFF) at RCWV or Max. Keep the resistor at 70±2°C ambient
Temperature Cycle	J: $\Delta R \leq \pm(1\% + 1m\Omega)$ F: $\Delta R \leq \pm(0.5\% + 1m\Omega)$ No mechanical damage	IEC 60115-1 / JIS C 5201-1 , Clause 4.19 Repeat 5 cycles as follows -55°C (30 min.) + 25°C (2~3 min.) +125°C (30 min.) + 25°C (2~3 min.) for 0201 55°C (30 min.) + 25°C (2~3 min.) +155°C (30 min.) + 25°C (2~3 min.) for others
Insulation Resistance	Between termination and coating must be over 1000MΩ	IEC 60115-1 / JIS C 5201-1 , Clause 4.6 Test voltage: 100±15V
Bending Strength	J: $\Delta R \leq \pm(1\% + 1m\Omega)$ F: $\Delta R \leq \pm(0.5\% + 1m\Omega)$ No mechanical damage	IEC 60115-1 / JIS C 5201-1 , Clause 4.33 Resistance change after bended on the 90mm PCB. Bend: 3mm for 0603 、 0805 2mm for 1206 、 2010 、 2512
Anti-sulfurate products require	$\Delta R \leq \pm(1\% + 0.1\Omega)$ No mechanical damage	IEC 60068-2-43/42 H ₂ S: 10-15 ppm SO ₂ :25±5 ppm 25±2°C RH 75% 240Hrs

All product specification and data are subject to change without notice