

54F/74F646 • 74F646B • 54F/74F648

Octal Transceiver/Register with TRI-STATE® Outputs

General Description

These devices consist of bus transceiver circuits with TRI-STATE, D-type flip-flops, and control circuitry arranged for multiplexed transmission of data directly from the input bus or from the internal registers. Data on the A or B bus will be clocked into the registers as the appropriate clock pin goes to a high logic level. Control \bar{G} and direction pins are provided to control the transceiver function. In the transceiver mode, data present at the high impedance port may be stored in either the A or the B register or in both. The select controls can multiplex stored and real-time (transparent mode) data. The direction control determines which bus will receive data when the enable control \bar{G} is Active LOW. In the isolation mode (control \bar{G} HIGH), A data may be stored in the B register and/or B data may be stored in the A register.

Features

- Independent registers for A and B buses
- Multiplexed real-time and stored data
- 'F648 has inverting data paths
- 'F646/'F646B have non-inverting data paths
- 'F646B is a faster version of the 'F646
- TRI-STATE outputs
- 300 mil slim DIP
- Guaranteed 4000V minimum ESD protection

Ordering Code: See Section 11

Commercial	Military	Package Number	Package Description
74F646SPC		N24C	24-Lead (0.300" Wide) Molded Dual-In-Line
	54F646DM (Note 2)	J24F	24-Lead (0.300" Wide) Ceramic Dual-In-Line
74F646SC (Note 1)		M24B	24-Lead (0.300" Wide) Molded Small Outline, JEDEC
74F646MSA (Note 1)		MSA24	24-Lead Molded Shrink Small Outline, EIAJ, Type II
	54F646FM (Note 2)	W24C	24-Lead Cerpack
	54F646LM (Note 2)	E28A	28-Lead Ceramic Leadless Chip Carrier, Type C
74F646BSPC		N24C	24-Lead (0.300" Wide) Molded Dual-In-Line
74F646BSC (Note 1)		M24B	24-Lead (0.300" Wide) Molded Small Outline, JEDEC
74F648SPC		N24C	24-Lead (0.300" Wide) Molded Dual-In-Line
	54F648SDM (Note 2)	J24F	24-Lead (0.300" Wide) Ceramic Dual-In-Line
74F648SC (Note 1)		M24B	24-Lead (0.300" Wide) Molded Small Outline, JEDEC
	54F648FM (Note 2)	W24C	24-Lead Cerpack
	54F648LM (Note 2)	E28A	24-Lead Ceramic Leadless Chip Carrier, Type C

Note 1: Devices also available in 13" reel. Use suffix = SCX.

Note 2: Military grade device with environmental and burn-in processing. Use suffix = DMOB, FMOB and LMOB.

Logic Symbols

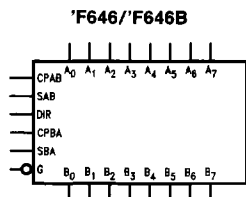

TL/F/9580-1

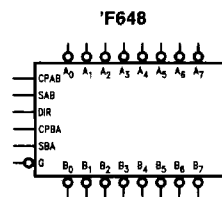

TL/F/9580-7

Logic Symbols (Continued)

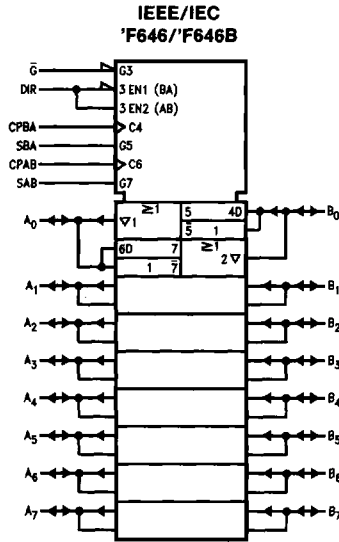

TL/F/9580-4

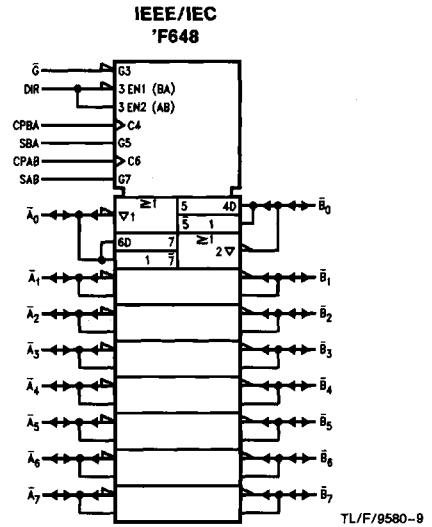

TL/F/9580-9

Connection Diagrams

**Pin Assignment
for DIP, SOIC and Flatpak
'F646/'F646B**

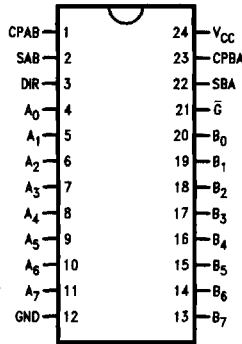

TL/F/9580-2

**Pin Assignment
for DIP, SOIC and Flatpak
'F648**

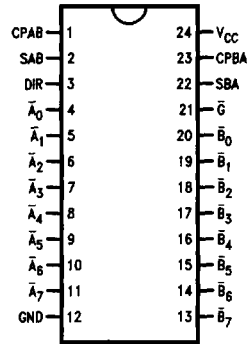

TL/F/9580-8

**Pin Assignment
for LCC
'F646/'F646B**

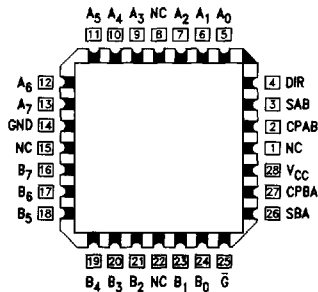

TL/F/9580-3

**Pin Assignment
for LCC
'F648**

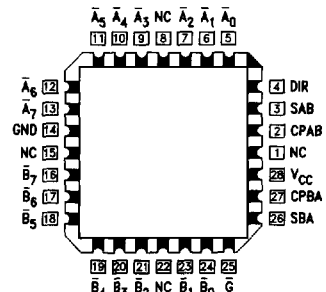

TL/F/9580-10

Unit Loading/Fan Out: See Section 2 for U.L. definitions

Pin Names	Description	54F/74F	
		U.L. HIGH/LOW	Input I _{IH} /I _{IL} Output I _{OH} /I _{OL}
A ₀ -A ₇	Data Register A Inputs/ TRI-STATE Outputs	3.5/1.083 600/106.6 (80)	70 μA/ -650 μA -12 mA/64 mA (48 mA)
B ₀ -B ₇	Data Register B Inputs/ TRI-STATE Outputs	3.5/1.083 600/106.6 (80)	70 μA/ -650 μA -12 mA/64 mA (48 mA)
CPAB, CPBA	Clock Pulse Inputs	1.0/1.0	20 μA/ -0.6 mA
SAB, SBA	Select Inputs	1.0/1.0	20 μA/ -0.6 mA
\bar{G}	Output Enable Input	1.0/1.0	20 μA/ -0.6 mA
DIR	Direction Control Input	1.0/1.0	20 μA/ -0.6 mA

Function Table

Inputs						Data I/O*		Function
\bar{G}	DIR	CPAB	CPBA	SAB	SBA	A ₀ -A ₇	B ₀ -B ₇	
H	X	H or L	H or L	X	X	Input	Input	Isolation
H	X	↗	X	X	X			Clock A _n Data into A Register
H	X	X	↘	X	X			Clock B _n Data into B Register
L	H	X	X	L	X	Input	Output	A _n to B _n —Real Time (Transparent Mode)
L	H	↗	X	L	X			Clock A _n Data into A Register
L	H	H or L	X	H	X			A Register to B _n (Stored Mode)
L	H	↘	X	H	X			Clock A _n Data into A Register and Output to B _n
L	L	X	X	X	L	Output	Input	B _n to A _n —Real Time (Transparent Mode)
L	L	X	↗	X	L			Clock B _n Data into B Register
L	L	X	H or L	X	H			B Register to A _n (Stored Mode)
L	L	X	↘	X	H			Clock B _n Data into B Register and Output to A _n

*The data output functions may be enabled or disabled by various signals at the \bar{G} and DIR inputs. Data input functions are always enabled; i.e., data at the bus pins will be stored on every LOW-to-HIGH transition of the clock inputs.

- H = HIGH Voltage Level
- L = LOW Voltage Level
- X = Irrelevant
- ↗ = LOW-to-HIGH Transition

Logic Diagrams (Continued)

'F646/'F646B

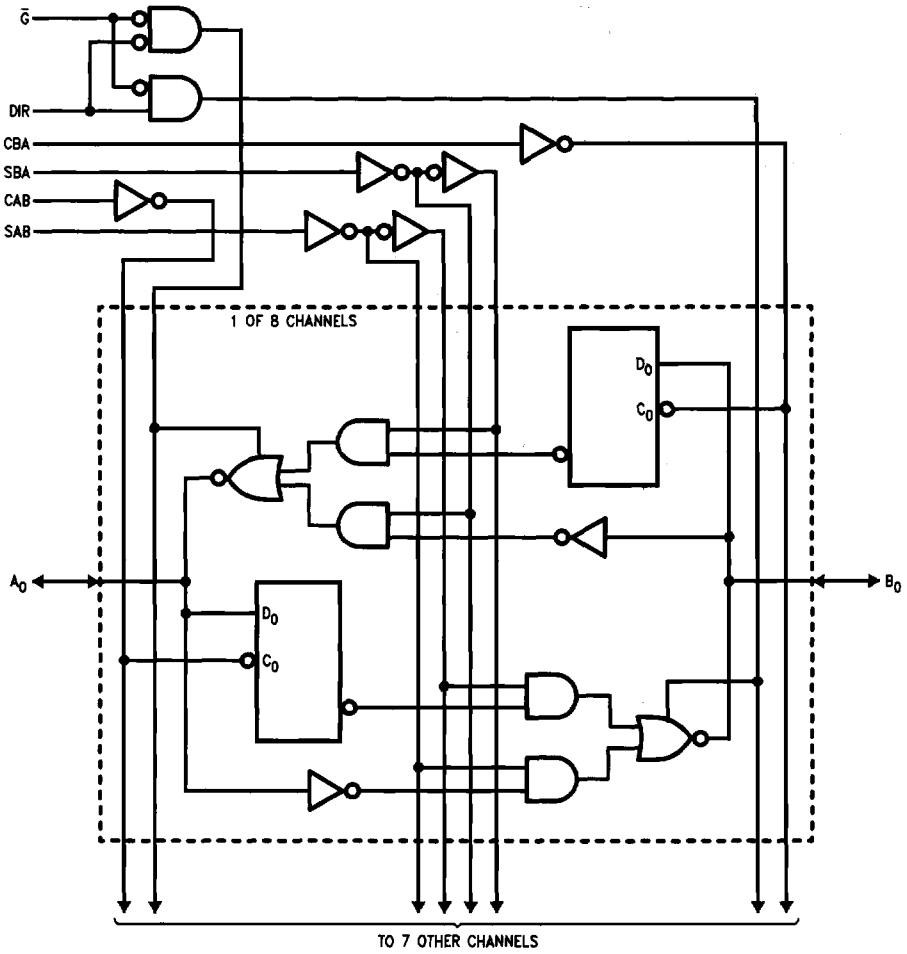

TL/F/9580-5

Please note that this diagram is provided only for the understanding of logic operations and should not be used to estimate propagation delays.

Logic Diagrams (Continued)

'F648

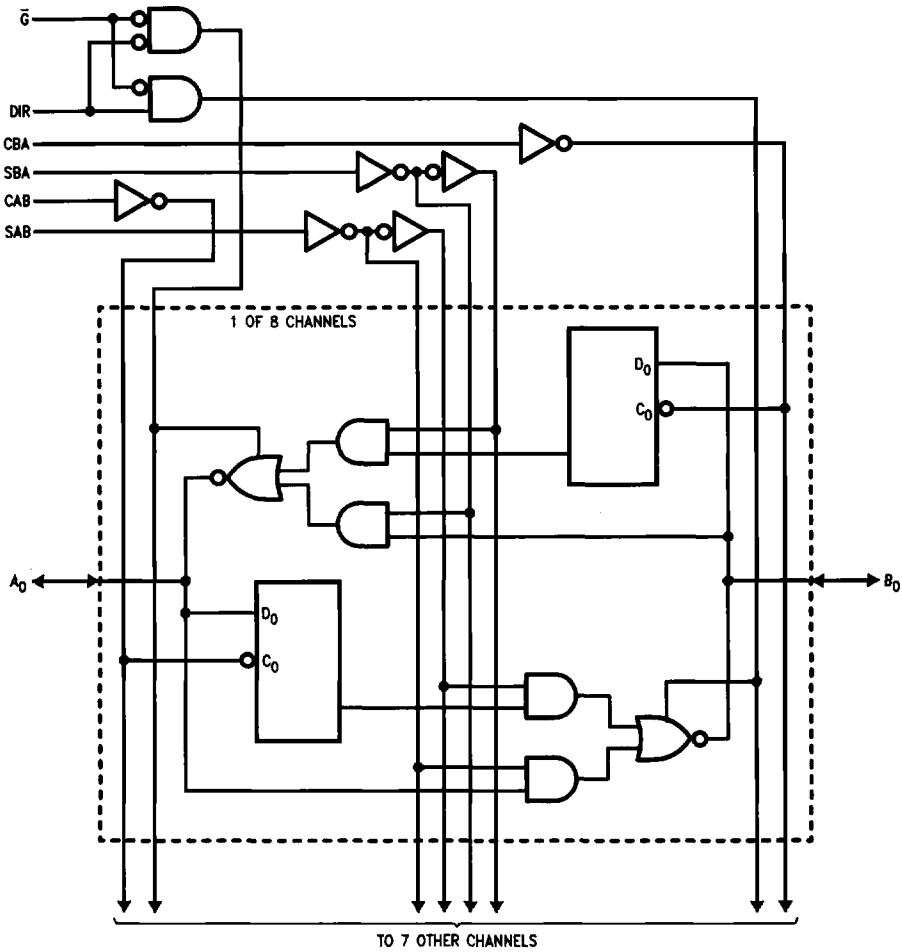

TL/F/9580-6

Please note that this diagram is provided only for the understanding of logic operations and should not be used to estimate propagation delays.

Absolute Maximum Ratings (Note 1)

If Military/Aerospace specified devices are required, please contact the National Semiconductor Sales Office/Distributors for availability and specifications.

Storage Temperature	-65°C to +150°C
Ambient Temperature under Bias	-55°C to +125°C
Junction Temperature under Bias	-55°C to +175°C
Plastic	-55°C to +150°C
V _{CC} Pin Potential to Ground Pin	-0.5V to +7.0V
Input Voltage (Note 2)	-0.5V to +7.0V
Input Current (Note 2)	-30 mA to +5.0 mA
Voltage Applied to Output in HIGH State (with V _{CC} = 0V)	
Standard Output	-0.5V to V _{CC}
TRI-STATE Output	-0.5V to +5.5V
Current Applied to Output in LOW State (Max)	twice the rated I _{OL} (mA)
ESD Last Passing Voltage (Min)	4000V

Note 1: Absolute maximum ratings are values beyond which the device may be damaged or have its useful life impaired. Functional operation under these conditions is not implied.

Note 2: Either voltage limit or current limit is sufficient to protect inputs.

Recommended Operating Conditions

Free Air Ambient Temperature	
Military	-55°C to +125°C
Commercial	0°C to +70°C
Supply Voltage	
Military	+4.5V to +5.5V
Commercial	+4.5V to +5.5V

DC Electrical Characteristics

Symbol	Parameter	54F/74F			Units	V _{CC}	Conditions
		Min	Typ	Max			
V _{IH}	Input HIGH Voltage	2.0			V		Recognized as a HIGH Signal
V _{IL}	Input LOW Voltage			0.8	V		Recognized as a LOW Signal
V _{CD}	Input Clamp Diode Voltage			-1.2	V	Min	I _{IN} = -18 mA (Non I/O Pins)
V _{OH}	Output HIGH Voltage	54F 10% V _{CC} 74F 10% V _{CC}	2.0 2.0		V	Min	I _{OH} = -12 mA (A _n , B _n) I _{OH} = -15 mA (A _n , B _n)
V _{OL}	Output LOW Voltage	54F 10% V _{CC} 74F 10% V _{CC}		0.55 0.55	V	Min	I _{OL} = 48 mA (A _n , B _n) I _{OL} = 64 mA (A _n , B _n)
I _{IH}	Input HIGH Current	54F 74F		20.0 5.0	μA	Max	V _{IN} = 2.7V (Non I/O Pins)
I _{BVI}	Input HIGH Current Breakdown Test	54F 74F		100 7.0	μA	Max	V _{IN} = 7.0V (Non I/O Pins)
I _{BVIT}	Input HIGH Current Breakdown (I/O)	54F 74F		1.0 0.5	mA	Max	V _{IN} = 5.5V (A _n , B _n)
I _{CEX}	Output HIGH Leakage Current	54F 74F		250 50	μA	Max	V _{OUT} = V _{CC}
V _{ID}	Input Leakage Test	74F	4.75		V	0.0	I _{ID} = 1.9 μA All Other Pins Grounded
I _{OD}	Output Leakage Circuit Current	74F		3.75	μA	0.0	V _{IOD} = 150 mV All Other Pins Grounded
I _{IL}	Input LOW Current			-0.6	mA	Max	V _{IN} = 0.5V (Non I/O Pins)
I _{IH} + I _{OZH}	Output Leakage Current			70	μA	Max	V _{OUT} = 2.7V (A _n , B _n)
I _{IL} + I _{OZL}	Output Leakage Current			-650	μA	Max	V _{OUT} = 0.5V (A _n , B _n)
I _{OS}	Output Short-Circuit Current			-100	mA	Max	V _{OUT} = 0V
I _{ZZ}	Bus Drainage Test			500	μA	0.0V	V _{OUT} = 5.25V
I _{CCH}	Power Supply Current			135	mA	Max	V _O = HIGH
I _{CCL}	Power Supply Current			150	mA	Max	V _O = LOW
I _{CCZ}	Power Supply Current			150	mA	Max	V _O = HIGH Z

'F646/'F648

AC Electrical Characteristics: See Section 2 for Waveforms and Load Configurations

Symbol	Parameter	74F		54F		74F		Units	Fig. No.
		$T_A = +25^\circ\text{C}$ $V_{CC} = +5.0\text{V}$ $C_L = 50\text{ pF}$		$T_A, V_{CC} = \text{Mil}$ $C_L = 50\text{ pF}$		$T_A, V_{CC} = \text{Com}$ $C_L = 50\text{ pF}$			
		Min	Max	Min	Max	Min	Max		
f_{max}	Maximum Clock Frequency	90		75		90		MHz	2-1
t_{PLH} t_{PHL}	Propagation Delay Clock to Bus	2.0	7.0	2.0	8.5	2.0	8.0	ns	2-3
t_{PLH} t_{PHL}	Propagation Delay Bus to Bus ('F646)	1.0	7.0	1.0	8.0	1.0	7.5	ns	2-3
t_{PLH} t_{PHL}	Propagation Delay Bus to Bus ('F648)	2.0	8.5	1.0	10.0	2.0	9.0	ns	2-3
t_{PLH} t_{PHL}	Propagation Delay SBA or SAB to A or B	2.0	8.5	2.0	11.0	2.0	9.5	ns	2-3
t_{PZH} t_{PZL}	Enable Time $\overline{\text{OE}}$ to A or B	2.0	8.5	2.0	10.0	2.0	9.0	ns	2-5
t_{PHZ} t_{PLZ}	Disable Time $\overline{\text{OE}}$ to A or B	1.0	7.5	1.0	9.0	1.0	8.5	ns	
t_{PZH} t_{PZL}	Enable Time DIR to A or B	2.0	14.0	2.0	16.0	2.0	15.0	ns	
t_{PHZ} t_{PLZ}	Disable Time DIR to A or B	1.0	9.0	1.0	10.0	1.0	9.5	ns	

'F646/'F648

AC Operating Requirements: See Section 2 for Waveforms

Symbol	Parameter	74F		54F		74F		Units	Fig. No.
		$T_A = +25^\circ\text{C}$ $V_{CC} = +5.0\text{V}$		$T_A, V_{CC} = \text{Mil}$		$T_A, V_{CC} = \text{Com}$			
		Min	Max	Min	Max	Min	Max		
$t_s(\text{H})$ $t_s(\text{L})$	Setup Time, HIGH or LOW Bus to Clock	5.0		5.0		5.0		ns	2-6
$t_h(\text{H})$ $t_h(\text{L})$	Hold Time, HIGH or LOW Bus to Clock	2.0		2.5		2.0		ns	2-6
$t_w(\text{H})$ $t_w(\text{L})$	Clock Pulse Width HIGH or LOW	5.0		5.0		5.0		ns	2-4

'F646B**AC Electrical Characteristics:** See Section 2 for Waveforms and Load Configurations

Symbol	Parameter	74F		54F		74F		Units	Fig. No.
		$T_A = +25^\circ\text{C}$ $V_{CC} = +5.0\text{V}$ $C_L = 50\text{ pF}$		$T_A, V_{CC} = \text{MII}$ $C_L = 50\text{ pF}$		$T_A, V_{CC} = \text{Com}$ $C_L = 50\text{ pF}$			
		Min	Max	Min	Max	Min	Max		
f_{max}	Maximum Clock Frequency	165				150		MHz	2-1
t_{PLH} t_{PHL}	Propagation Delay Clock to Bus	2.5 3.0	7.0 7.5			2.5 3.0	8.0 8.0	ns	2-3
t_{PLH} t_{PHL}	Propagation Delay Bus to Bus	2.0 2.0	6.0 6.0			2.0 2.0	7.0 7.0	ns	2-3
t_{PLH} t_{PHL}	Propagation Delay SBA or SAB to A or B	2.5 2.5	7.5 7.5			2.5 2.5	8.5 8.5	ns	2-3
t_{PZH} t_{PZL}	Enable Time OE to A or B	2.5 2.5	6.5 9.0			2.5 2.5	8.0 10.0	ns	2-5
t_{PHZ} t_{PLZ}	Disable Time OE to A or B	1.5 2.0	6.5 7.0			1.5 2.0	7.5 8.5	ns	
t_{PZH} t_{PZL}	Enable Time DIR to A or B	2.0 3.0	7.0 9.5			2.0 3.0	8.5 10.0	ns	
t_{PHZ} t_{PLZ}	Disable Time DIR to A or B	1.5 2.5	7.5 8.5			1.5 2.5	8.5 9.5	ns	

'F646B**AC Operating Requirements:** See Section 2 for Waveforms

Symbol	Parameter	74F		54F		74F		Units	Fig. No.
		$T_A = +25^\circ\text{C}$ $V_{CC} = +5.0\text{V}$		$T_A, V_{CC} = \text{MII}$		$T_A, V_{CC} = \text{Com}$			
		Min	Max	Min	Max	Min	Max		
$t_{\text{S}}(\text{H})$ $t_{\text{S}}(\text{L})$	Setup Time, HIGH or LOW Bus to Clock	5.0 5.0				4.0 4.0		ns	2-6
$t_{\text{H}}(\text{H})$ $t_{\text{H}}(\text{L})$	Hold Time, HIGH or LOW Bus to Clock	1.5 1.5				1.5 1.5		ns	2-6
$t_{\text{W}}(\text{H})$ $t_{\text{W}}(\text{L})$	Clock Pulse Width HIGH or LOW	5.0 5.0				5.0 5.0		ns	2-4