

TYPES SN5420, SN54H20, SN54L20, SN54LS20, SN54S20, SN7420, SN74H20, SN74LS20, SN74S20 DUAL 4-INPUT POSITIVE-NAND GATES

REVISED DECEMBER 1983

- Package Options Include Both Plastic and Ceramic Chip Carriers in Addition to Plastic and Ceramic DIPs
- Dependable Texas Instruments Quality and Reliability

description

These devices contain two independent 4-input NAND gates.

The SN5420, SN54H20, SN54L20, SN54LS20 and SN54S20 are characterized for operation over the full military range of -55°C to 125°C . The SN7420, SN74H20, SN74LS20 and SN74S20 are characterized for operation from 0°C to 70°C .

FUNCTION TABLE (each gate)

INPUTS				OUTPUT
A	B	C	D	Y
H	H	H	H	L
L	X	X	X	H
X	L	X	X	H
X	X	L	X	H
X	X	X	L	H

logic diagram (each gate)

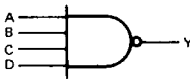

positive logic

$$Y = \overline{A \cdot B \cdot C \cdot D} \text{ or } Y = \overline{A} + \overline{B} + \overline{C} + \overline{D}$$

SN5420, SN54H20, SN54L20 ... J PACKAGE
SN54LS20, SN54S20 ... J OR W PACKAGE
SN7420, SN74H20 ... J OR N PACKAGE
SN74LS20, SN74S20 ... D, J OR N PACKAGE
(TOP VIEW)

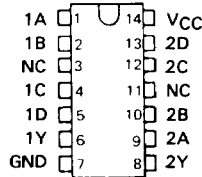

SN5420, SN54H20 ... W PACKAGE
(TOP VIEW)

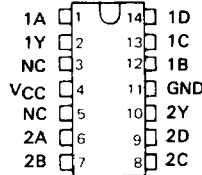

SN54LS20, SN54S20 ... FK PACKAGE
SN74LS20, SN74S20 ... FN PACKAGE
(TOP VIEW)

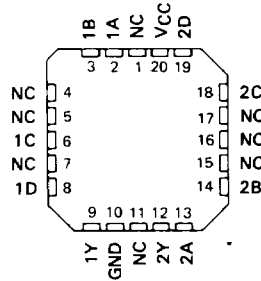

NC - No internal connection

3

TTL DEVICES

TYPES SN5420, SN54H20, SN54L20, SN54LS20, SN54S20, SN7420, SN74H20, SN74LS20, SN74S20 DUAL 4-INPUT POSITIVE-NAND GATES

schematics (each gate)

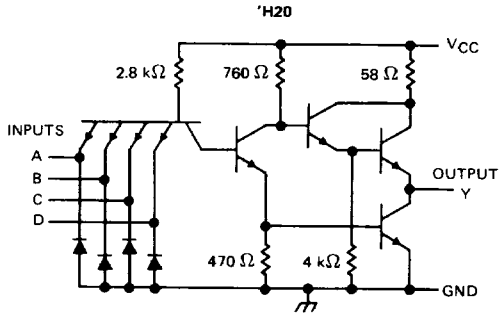
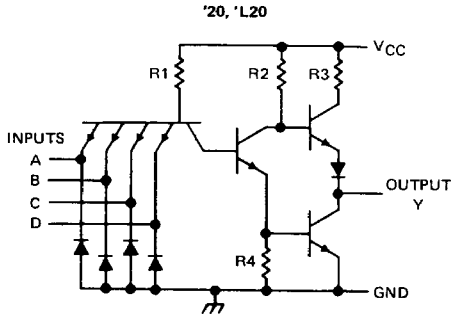

CIRCUIT	R1	R2	R3	R4
'20	4 kΩ	1.6 kΩ	130 Ω	1 kΩ
'L20	40 kΩ	20 kΩ	500 Ω	12 kΩ

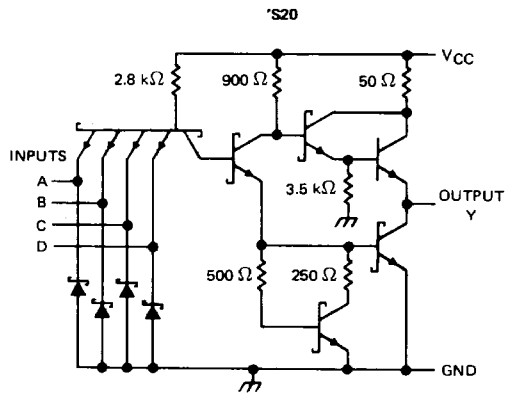
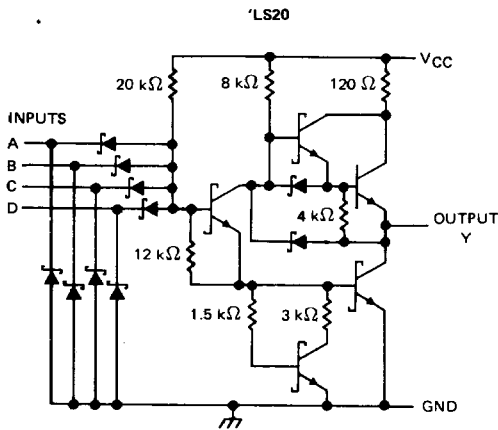

Resistor values shown are nominal.

absolute maximum ratings over operating free-air temperature range (unless otherwise noted)

Supply voltage, V_{CC} (see Note 1): '20, 'H20, 'LS20, 'S20	7 V
'L20	8 V
Input voltage: '20, 'H20, 'L20, 'S20	5.5 V
'LS20	7 V
Operating free-air temperature: SN54'	-55°C to 125°C
SN74'	0°C to 70°C
Storage temperature range	-65°C to 150°C

NOTE 1: Voltage values are with respect to network ground terminal.

TYPES SN5420, SN7420 DUAL 4-INPUT POSITIVE-NAND GATES

recommended operating conditions

	SN5420			SN7420			UNIT
	MIN	NOM	MAX	MIN	NOM	MAX	
V _{CC} Supply voltage	4.5	5	5.5	4.75	5	5.25	V
V _{IH} High-level input voltage	2			2			V
V _{IL} Low-level input voltage	0.8			0.8			V
I _{OH} High-level output current	-0.4			-0.4			mA
I _{OL} Low-level output current	16			16			mA
T _A Operating free-air temperature	-55			0			70 °C

electrical characteristics over recommended operating free-air temperature range (unless otherwise noted)

PARAMETER	TEST CONDITIONS †	SN5420			SN7420			UNIT
		MIN	TYP ‡	MAX	MIN	TYP ‡	MAX	
V _{IK}	V _{CC} = MIN, I _I = -12 mA	-1.5			-1.5			V
V _{OH}	V _{CC} = MIN, V _{IL} = 0.8 V, I _{OH} = -0.4 mA	2.4	3.4		2.4	3.4	V	
V _{OL}	V _{CC} = MIN, V _{IH} = 2 V, I _{OL} = 16 mA	0.2		0.4	0.2		0.4	V
I _I	V _{CC} = MAX, V _I = 5.5 V	1			1			mA
I _{IH}	V _{CC} = MAX, V _I = 2.4 V	40			40			µA
I _{IL}	V _{CC} = MAX, V _I = 0.4 V	-1.6			-1.6			mA
I _{OS} §	V _{CC} = MAX	-20		-55	-18		-55	mA
I _{CCH}	V _{CC} = MAX, V _I = 0 V	2		4	2		4	mA
I _{CCL}	V _{CC} = MAX, V _I = 4.5 V	6		11	6		11	mA

† For conditions shown as MIN or MAX, use the appropriate value specified under recommended operating conditions.

‡ All typical values are at V_{CC} = 5 V, T_A = 25°C.

§ Not more than one output should be shorted at a time.

switching characteristics, V_{CC} = 5 V, T_A = 25°C (see note 2)

PARAMETER	FROM (INPUT)	TO (OUTPUT)	TEST CONDITIONS	MIN	TYP	MAX	UNIT
t _{PLH}	Any	Y	R _L = 400 Ω, C _L = 15 pF		12	22	ns
t _{PHL}				8	15	ns	

NOTE 2: See General Information Section for load circuits and voltage waveforms.

3

TTL DEVICES

TYPES SN54H20, SN74H20

DUAL 4-INPUT POSITIVE-NAND GATES

recommended operating conditions

	SN54H20			SN74H20			UNIT
	MIN	NOM	MAX	MIN	NOM	MAX	
V _{CC} Supply voltage	4.5	5	5.5	4.75	5	5.25	V
V _{IH} High-level input voltage	2			2			V
V _{IL} Low-level input voltage			0.8			0.8	V
I _{OH} High-level output current			-0.5			-0.5	mA
I _{OL} Low-level output current			20			20	mA
T _A Operating free-air temperature	-55		125	0		70	°C

electrical characteristics over recommended operating free-air temperature range (unless otherwise noted)

PARAMETER	TEST CONDITIONS †	MIN	TYP ‡	MAX	UNIT
V _{IK}	V _{CC} = MIN, I _I = -8 mA			-1.5	V
V _{OH}	V _{CC} = MIN, V _{IL} = 0.8 V, I _{OH} = -0.5 mA	2.4	3.5		V
V _{OL}	V _{CC} = MIN, V _{IH} = 2 V, I _{OL} = 20 mA		0.2	0.4	V
I _I	V _{CC} = MAX, V _I = 5.5 V			1	mA
I _{IH}	V _{CC} = MAX, V _I = 2.4 V			50	μA
I _{IL}	V _{CC} = MAX, V _I = 0.4 V			-2	mA
I _{OS} §	V _{CC} = MAX	-40		-100	mA
I _{CCH}	V _{CC} = MAX, V _I = 0 V		5	8.4	mA
I _{CCL}	V _{CC} = MAX, V _I = 4.5 V		13	20	mA

† For conditions shown as MIN or MAX, use the appropriate value specified under recommended operating conditions.

‡ All typical values are at V_{CC} = 5 V, T_A = 25°C.

§ Not more than one output should be shorted at a time, and the duration of the short-circuit should not exceed one second.

switching characteristics, V_{CC} = 5 V, T_A = 25°C (see note 2)

PARAMETER	FROM (INPUT)	TO (OUTPUT)	TEST CONDITIONS		MIN	TYP	MAX	UNIT
t _{PLH}	Any	Y	R _L = 280 Ω,	C _L = 25 pF		6	10	ns
t _{PHL}						7	10	ns

NOTE 2: See General Information Section for load circuits and voltage waveforms.

TYPE SN54L20
DUAL 4-INPUT POSITIVE-NAND GATES

recommended operating conditions

	SN54L20			UNIT
	MIN	NOM	MAX	
V _{CC} Supply voltage	4.5	5	5.5	V
V _{IH} High-level input voltage	2			V
V _{IL} Low-level input voltage			0.7	V
I _{OH} High-level output current			-0.1	mA
I _{OL} Low-level output current			2	mA
T _A Operating free-air temperature	-55		125	°C

electrical characteristics over recommended operating free-air temperature range (unless otherwise noted)

PARAMETER	TEST CONDITIONS †	SN54L20			UNIT
		MIN	TYP ‡	MAX	
V _{OH}	V _{CC} = MIN, V _{IL} = 0.7 V, I _{OH} = -0.1 mA	2.4	3.3		V
V _{OL}	V _{CC} = MIN, V _{IH} = 2 V, I _{OL} = 2 mA		0.15	0.3	V
I _I	V _{CC} = MAX, V _I = 5.5 V			0.1	mA
I _{IH}	V _{CC} = MAX, V _I = 2.4 V			10	μA
I _{IL}	V _{CC} = MAX, V _I = 0.3 V			-0.18	mA
I _{OS} §	V _{CC} = MAX	-3		-15	mA
I _{CCH}	V _{CC} = MAX, V _I = 0 V		0.22	0.4	mA
I _{CCL}	V _{CC} = MAX, V _I = 4.5 V		0.58	1.02	mA

† For conditions shown as MIN or MAX, use the appropriate value specified under recommended operating conditions.

‡ All typical values are at V_{CC} = 5 V, T_A = 25°C.

§ Not more than one output should be shorted at a time.

switching characteristics, V_{CC} = 5 V, T_A = 25°C (see note 2)

PARAMETER	FROM (INPUT)	TO (OUTPUT)	TEST CONDITIONS	MIN	TYP	MAX	UNIT
t _{PLH}	Any	Y	R _L = 4 kΩ, C _L = 50 pF		35	60	ns
t _{PHL}					31	60	ns

NOTE 2: See General Information Section for load circuits and voltage waveforms.

3

TTL DEVICES

TYPES SN54LS20, SN74LS20

DUAL 4-INPUT POSITIVE-NAND GATES

recommended operating conditions

	SN54LS20			SN74LS20			UNIT
	MIN	NOM	MAX	MIN	NOM	MAX	
V _{CC} Supply voltage	4.5	5	5.5	4.75	5	5.25	V
V _{IH} High-level input voltage	2			2			V
V _{IL} Low-level input voltage			0.7			0.8	V
I _{OH} High-level output current			-0.4			-0.4	mA
I _{OL} Low-level output current			4			8	mA
T _A Operating free-air temperature	-55		125	0		70	°C

electrical characteristics over recommended operating free-air temperature range (unless otherwise noted)

PARAMETER	TEST CONDITIONS †	SN54LS20		SN74LS20		UNIT		
		MIN	TYP‡	MAX	MIN		TYP‡	MAX
V _{IK}	V _{CC} = MIN, I _I = -18 mA			-1.5		-1.5	V	
V _{OH}	V _{CC} = MIN, V _{IL} = MAX, I _{OH} = -0.4 mA	2.5	3.4		2.7	3.4	V	
V _{OL}	V _{CC} = MIN, V _{IH} = 2 V, I _{OL} = 4 mA		0.25	0.4		0.4	V	
	V _{CC} = MIN, V _{IH} = 2 V, I _{OL} = 8 mA				0.25	0.5		
I _I	V _{CC} = MAX, V _I = 7 V			0.1		0.1	mA	
I _{IH}	V _{CC} = MAX, V _I = 2.7 V			20		20	μA	
I _{IL}	V _{CC} = MAX, V _I = 0.4 V			-0.4		-0.4	mA	
I _{OS} §	V _{CC} = MAX	-20		-100	-20	-100	mA	
I _{CCH}	V _{CC} = MAX, V _I = 0 V		0.4	0.8		0.4	0.8	mA
I _{CCL}	V _{CC} = MAX, V _I = 4.5 V		1.2	2.2		1.2	2.2	mA

† For conditions shown as MIN or MAX, use the appropriate value specified under recommended operating conditions.

‡ All typical values are at V_{CC} = 5 V, T_A = 25°C.

§ Not more than one output should be shorted at a time, and the duration of the short-circuit should not exceed one second.

switching characteristics, V_{CC} = 5 V, T_A = 25°C (see note 2)

PARAMETER	FROM (INPUT)	TO (OUTPUT)	TEST CONDITIONS		MIN	TYP	MAX	UNIT
t _{PLH}	Any	Y	R _L = 2 kΩ,	C _L = 15 pF		9	15	ns
t _{PHL}						10	15	ns

NOTE 2: See General Information Section for load circuits and voltage waveforms.

TYPES SN54S20, SN74S20 DUAL 4-INPUT POSITIVE-NAND GATES

recommended operating conditions

	SN54S20			SN74S20			UNIT
	MIN	NOM	MAX	MIN	NOM	MAX	
V _{CC} Supply voltage	4.5	5	5.5	4.75	5	5.25	V
V _{IH} High-level input voltage	2			2			V
V _{IL} Low-level input voltage	0.8			0.8			V
I _{OH} High-level output current	-1			-1			mA
I _{OL} Low-level output current	20			20			mA
T _A Operating free-air temperature	-55			0			70 °C

electrical characteristics over recommended operating free-air temperature range (unless otherwise noted)

PARAMETER	TEST CONDITIONS †	SN54S20			SN74S20			UNIT
		MIN	TYP ‡	MAX	MIN	TYP ‡	MAX	
V _{IK}	V _{CC} = MIN, I _I = -18 mA	-1.2			-1.2			V
V _{OH}	V _{CC} = MIN, V _{IL} = 0.8 V, I _{OH} = -1 mA	2.5	3.4		2.7	3.4		V
V _{OL}	V _{CC} = MIN, V _{IH} = 2 V, I _{OL} = 20 mA	0.5			0.5			V
I _I	V _{CC} = MAX, V _I = 5.5 V	1			1			mA
I _{IH}	V _{CC} = MAX, V _I = 2.7 V	50			50			μA
I _{IL}	V _{CC} = MAX, V _I = 0.5 V	-2			-2			mA
I _{OS} §	V _{CC} = MAX	-40	-100		-40	-100		mA
I _{CCH}	V _{CC} = MAX, V _I = 0 V	5			5			8 mA
I _{CCL}	V _{CC} = MAX, V _I = 4.5 V	10			10			18 mA

† For conditions shown as MIN or MAX, use the appropriate value specified under recommended operating conditions.

‡ All typical values are at V_{CC} = 5 V, T_A = 25°C.

§ Not more than one output should be shorted at a time, and the duration of the short-circuit should not exceed one second.

switching characteristics, V_{CC} = 5 V, T_A = 25°C (see note 2)

PARAMETER	FROM (INPUT)	TO (OUTPUT)	TEST CONDITIONS		MIN	TYP	MAX	UNIT
t _{PLH}	A, B, C or D	Y	R _L = 280 Ω,	C _L = 15 pF		3	4.5	ns
t _{PHL}						3	5	ns
t _{PLH}			R _L = 280 Ω,	C _L = 50 pF		4.5		ns
t _{PHL}						5		ns

NOTE 2: See General Information Section for load circuits and voltage waveforms.

3

TTL DEVICES