

REGULATING PULSE WIDTH MODULATORS

CURRENT MODE IP1842, IP2842, IP3842, IP1843, IP2843, IP3843

DESCRIPTION

The IP1842 and IP1843 series of switching regulator control circuits contain all the functions necessary to implement off-line, current mode switching regulators, using a minimum number of external parts. Functions included are voltage reference, error amplifier, current sense comparator, oscillator, totem-pole output driver and under-voltage lockout circuitry.

Although pin compatible with the UC1842 and UC1843 series, Seagate Microelectronics has incorporated several improvements in the IP1842 and IP1843 series allowing tighter and more complete specification of electrical performance.

FEATURES

- Guaranteed $\pm 1\%$ reference voltage tolerance
- Guaranteed $\pm 10\%$ frequency tolerance
- Low start-up current ($< 500 \mu\text{A}$)
- Under voltage lockout with hysteresis
- Output state completely defined for all supply and input conditions
- Interchangeable with UC1842 and UC1843 series for improved operation
- 500 kHz operation

2

BLOCK DIAGRAM

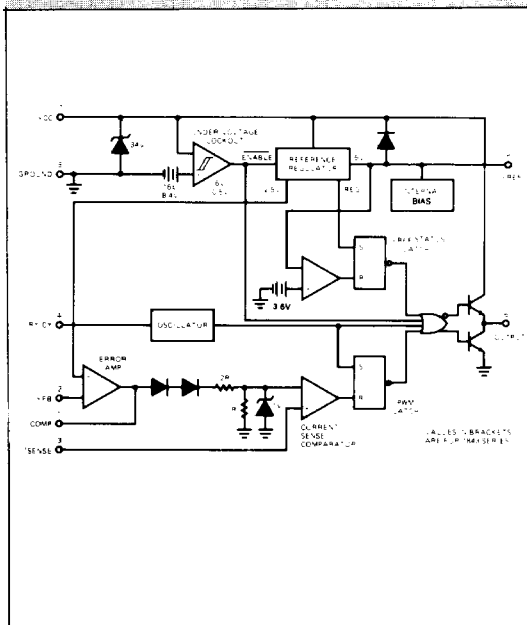

CONNECTIONS

(Top View)

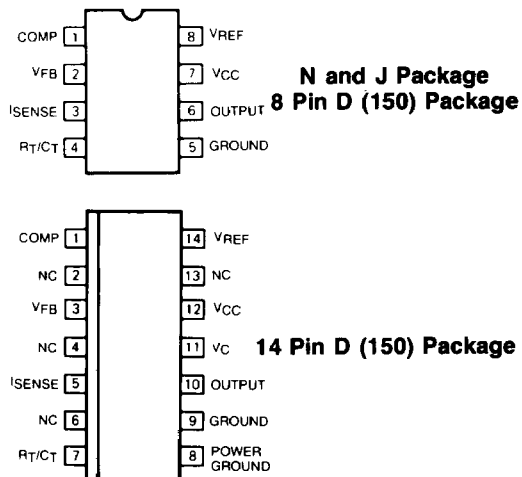

CURRENT MODE IP1842, IP2842, IP3842, IP1843, IP2843, IP3843

REGULATING PULSE WIDTH MODULATORS

ABSOLUTE MAXIMUM RATINGS

Supply Voltage (+V _{CC}) (low impedance source)	+30V	Error Amp Output Sink Current	10mA
Supply Voltage (V _{CC}) (I _{CC} < 30mA)	Self limiting	Power Dissipation at T _A = +25°C (Note 1)	1000mW
Output Current	±1A	T _C = +25°C (Note 2)	2000mW
Output Energy (capacitive load)	μJ	Storage Temperature Range	-65°C to +150°C
Analog Inputs (pins 2 and 3)	-0.3V to +V _{CC}	Lead Temperature (Soldering, 10 seconds)	+300°C

Absolute maximum ratings are those values beyond which the safety of the device cannot be guaranteed. They are not meant to imply that the device should be operated at these limits. The electrical characteristics provide conditions for actual device operation.

RECOMMENDED OPERATING CONDITIONS (Note 3)

Supply Voltage (+V _{CC}) (Note 4)	≤30V	Operating Ambient Temperature Range:	
Output Current	0 to ±200mA	IP1842, IP1843	-55°C to +125°C
Analog Inputs (pins 2 and 3)	-0.3 to 3 V	IP2842, IP2843	-25°C to +85°C
Error Amp Output Sink Current	0 to 2mA	IP3842, IP3843	0°C to +70°C

Note 1. Derate at 10 mW/°C for ambient temperatures above +50°C.

Note 2. Derate at 24 mW/°C for case temperatures above +25°C.

Note 3. Range over which the device is functional and parameter limits are guaranteed.

Note 4. Lower limit set by under voltage lockout specification.

ELECTRICAL CHARACTERISTICS

V_{CC} = 15V, f = 52kHz, R_T = 10k, C_T = 3.3nF unless otherwise specified (Note 6)

Parameter	Test Conditions	IP1842/IP1843 IP2842/IP2843			IP3842/IP3843			Units	
		Min	Typ	Max	Min	Typ	Max		
Reference Section									
Output Voltage	I _O = 1mA	4.95	5.00	5.05	4.90	5.00	5.10	V	
Input Regulation	V _{CC} = 12 to 25V	●	6	20		6	20	mV	
Output Regulation	I _O = 1 to 20mA	●	6	25		6	25	mV	
Temperature Stability	(Note 5)	●	0.2	0.4		0.2	0.4	mV/°C	
Total Output Variation	Line, Load, Temp	●	4.90	5.10	4.82		5.18	V	
Output Noise Voltage	f = 10Hz to 10kHz (Note 5)		50			50		μV	
Long Term Stability	T _j = 125°C 1000 Hrs (Note 5)		5	25		5	25	mV	
Output Short Circuit Current	V _{REF} = 0	●	30	80	160	30	80	160	mA
Oscillator Section									
Frequency			47	52	57	47	52	57	kHz
Voltage Stability	V _{CC} = 12 to 25V	●		0.2	1		0.2	1	%
Temperature Stability	ΔT _A = Min to Max (Note 5)	●		5			5		%
Amplitude	V _{PIN 4} Peak to Peak	●		1.7			1.7		V
Discharge Current				8.3			8.3		mA
	ΔT _A = Min to Max (Note 5)			8			8		%



REGULATING PULSE WIDTH MODULATORS

ELECTRICAL CHARACTERISTICS (CONTINUED)

Parameter	Test Conditions		IP1842/IP1843 IP2842/IP2843			IP3842/IP3843			Units	
			Min	Typ	Max	Min	Typ	Max		
Error Amp Section										
Input Voltage	V _{PIN 1} = 2.5V	●	2.45	2.50	2.55	2.42	2.50	2.58	V	
Input Bias Current		●		-0.3	-1		-0.3	-2	μA	
Open Loop Voltage Gain	V _O = 2 to 4V	●	65	90		65	90		dB	
Unity Gain Bandwidth	(Note 5)	●	0.7	1		0.7	1		MHz	
Supply Voltage Rejection	V _{CC} = 12 to 25V	●	60	70		60	70		dB	
Output Sink Current	V _{PIN 2} = 2.7V, V _{PIN 1} = 1.1V	●	2	6		2	6		mA	
Output Source Current	V _{PIN 2} = 2.3V, V _{PIN 1} = 4.6V	●	-0.5	-0.8		-0.5	-0.8		mA	
V _{OUTH} High	V _{PIN 2} = 2.3V, R _L = 15k	●	4.6	4.8		4.6	4.8		V	
V _{OUT} Low	V _{PIN 2} = 2.7V, R _L = 15k	●		0.7	1.1		0.7	1.1	V	
Current Sense Section										
Gain	(Notes 7 and 8)	●	2.85	3	3.15	2.85	3	3.15	V/V	
Maximum Input Signal	V _{PIN 1} = 4.6V (Note 7)	●	0.9	1	1.1	0.9	1.0	1.1	V	
Supply Voltage Rejection	V _C = 12 to 25V	●	60	70		60	70		dB	
Input Bias Current		●		-2	-10		-2	-10	μA	
Delay to Output		●		200	400		200	400	ns	
Output Section										
Output Low Level	I _{SINK} = 20mA	●		0.1	0.4		0.1	0.4	V	
	I _{SINK} = 200mA	●		1.5	2.2		1.5	2.2	V	
Output High Level	I _{SOURCE} = 20mA	●	13	13.5		13	13.5		V	
	I _{SOURCE} = 200mA	●	12	13.5		12	13.5		V	
Rise Time	C _L = 1nF			50	150		50	150	ns	
Fall Time	C _L = 1nF			50	150		50	150	ns	
UVLO Saturation	V _{CC} = 6V, I _L = 1mA	●		0.7	1.1		0.7	1.1	V	
Under-voltage Lockout Section										
Upper Threshold (V _{CC})	1842 Series	●	15	16	17	14.5	16	17.5	V	
	1843 Series	●	7.8	8.4	9	7.8	8.4	9	V	
Lower Threshold (V _{CC})	1842 Series	●	9	10	11	8.5	10	11.5	V	
	1843 Series	●	7	7.6	8.2	7	7.6	8.2	V	
Total Standby Current										
Start-Up Current		●		0.3	0.5		0.3	0.5	mA	
Operating Supply Current	V _{PIN 2} = 0V	1842 Series	●		11	15		11	15	mA
	V _{PIN 3} = 0V	1843 Series	●		14	17		14	17	mA
V _{CC} Zener Voltage	I _{CC} = 25mA	●	30	34	40	30	34	40	V	

The ● denotes the specifications which apply over the full operating temperature range, all others apply at T_J = 25°C unless otherwise specified.
 Note 5. These parameters, although guaranteed over the recommended conditions, are not 100% tested in production.
 Note 6. Adjust V_{CC} above start threshold before setting at required level.
 Note 7. Parameter measured at trip point of latch with V_{PIN 2} = 0V.
 Note 8. Gain defined as

$$A = \frac{\Delta V_{PIN 1}}{\Delta V_{PIN 3}} \quad ; 0 \leq V_{PIN 3} \leq 0.8$$



REGULATING PULSE WIDTH MODULATORS

APPLICATIONS INFORMATION

2

Oscillator Waveforms and Maximum Duty Cycle

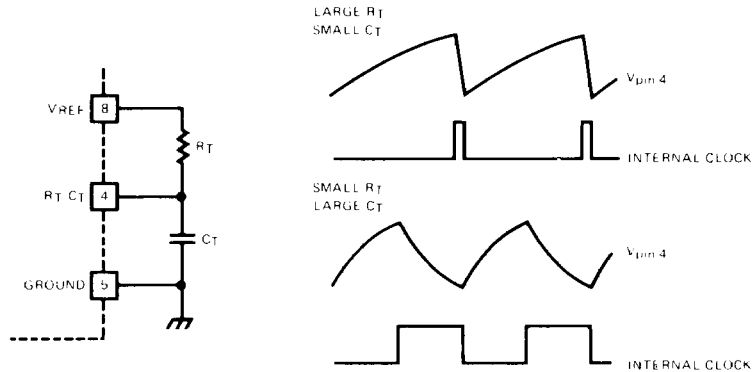

Oscillator timing capacitor, C_T is charged by V_{REF} through R_T and discharged by an internal current source. During the discharge time, the internal clock signal blanks the output to the low state. Selection of R_T and C_T therefore determines both oscillator frequency and maximum duty cycle. Charge and discharge times are determined by the formulas:

$$t_c \approx 0.55 R_T C_T$$

$$t_d \approx R_T C_T \ln \left(\frac{0.063 R_T - 2.3}{0.063 - 4} \right)$$

$$\text{Frequency, then is: } f = (t_c + t_d)^{-1}$$

$$\text{For } R_T > 5k, f \approx \frac{1.8}{R_T C_T}$$

Open-Loop Laboratory Test Fixture

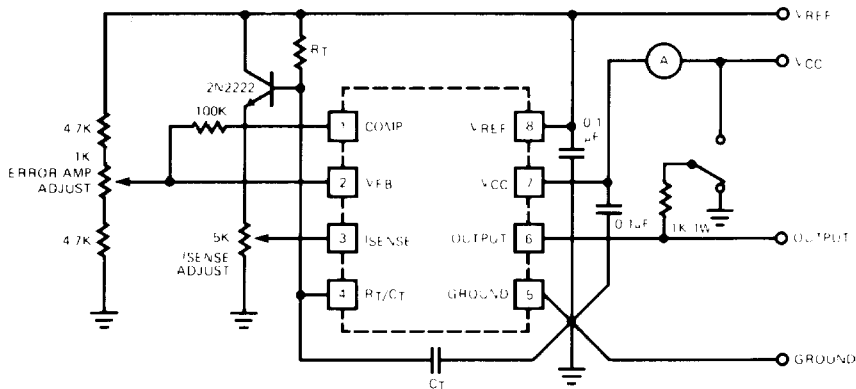

High peak current associated with capacitive loads necessitate careful grounding techniques. Timing and bypass capacitors should be connected close to pin 5 in a single point ground. The transistor and 5K potentiometer are used to sample the oscillator waveform and apply an adjustable ramp to pin 3



REGULATING PULSE WIDTH MODULATORS

TYPICAL PERFORMANCE CHARACTERISTICS

Output Saturation Characteristics

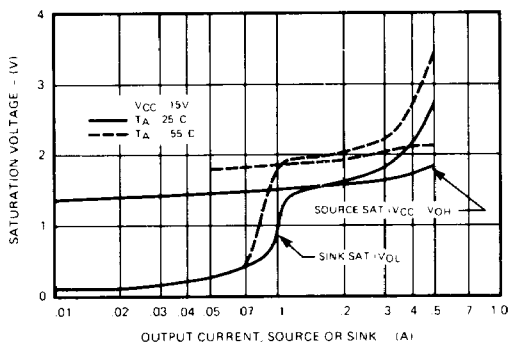

Error Amplifier Open-Loop Frequency Response

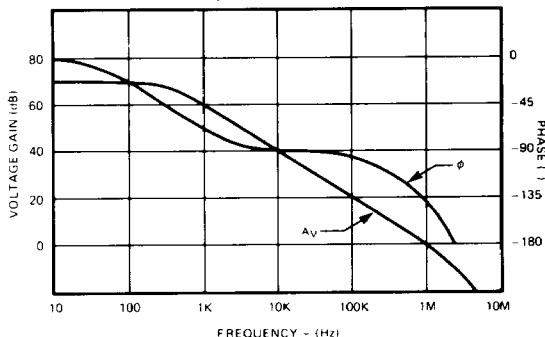

Under Voltage Lockout 1842 Series

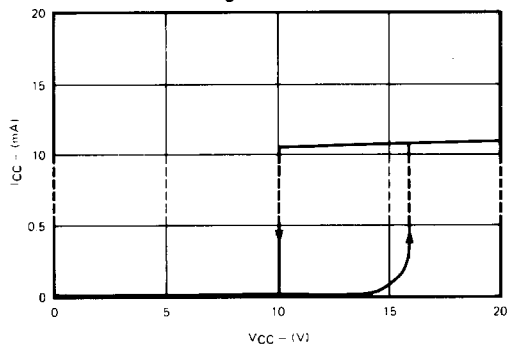

Under Voltage Lockout 1843 Series

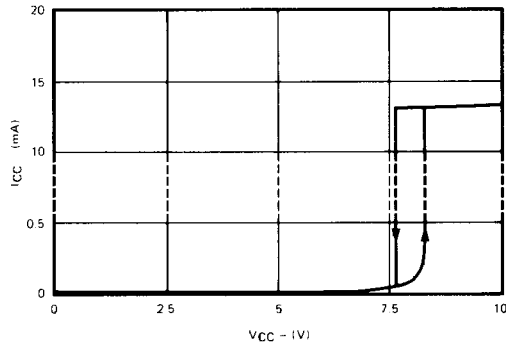

ORDER INFORMATION

Part Number

IP1842J
 IP2842J
 IP2842N
 IP2842D
 IP2842D-14
 IP3842J
 IP3842N
 IP3842D
 IP3842D-14

Temperature Range

-55°C to +125°C
 -25°C to +85°C
 -25°C to +85°C
 -25°C to +85°C
 -25°C to +85°C
 0°C to +70°C
 0°C to +70°C
 0°C to +70°C
 0°C to +70°C

Package

8 Pin Ceramic DIP
 8 Pin Ceramic DIP
 8 Pin Plastic DIP
 8 Pin Plastic (150) SOIC
 14 Pin Plastic (150)SOIC
 8 Pin Ceramic DIP
 8 Pin Plastic DIP
 8 Pin Plastic (150) SOIC
 14 Pin Plastic (150) SOIC

IP1843J
 IP2843J
 IP2843N
 IP2843D
 IP2843D-14
 IP3843J
 IP3843N
 IP3843D
 IP3843D-14

-55°C to +125°C
 -25°C to +85°C
 -25°C to +85°C
 -25°C to +85°C
 -25°C to +85°C
 0°C to +70°C
 0°C to +70°C
 0°C to +70°C
 0°C to +70°C

8 Pin Ceramic DIP
 8 Pin Ceramic DIP
 8 Pin Plastic DIP
 8 Pin Plastic (150) SOIC
 14 Pin Plastic (150) SOIC
 8 Pin Ceramic DIP
 8 Pin Plastic DIP
 8 Pin Plastic (150) SOIC
 14 Pin Plastic (150) SOIC

