

# NM93C06L/C46L/C56L/C66L

## 256-/1024-/2048-/4096-Bit Serial EEPROM

### with Extended Voltage (2.7V to 5.5V)

### (MICROWIRE™ Bus Interface)

#### General Description

The NM93C06L/C46L/C56L/C66L devices are 256/1024/2048/4096 bits, respectively, of non-volatile electrically erasable memory divided into 16/64/128/256 x 16-bit registers (addresses). The NM93CxxL Family functions in an extended voltage operating range, requires only a single power supply and is fabricated using National Semiconductor's floating gate CMOS technology for high reliability, high endurance and low power consumption. These devices are available in both SO and TSSOP packages for small space considerations.

The EEPROM Interfacing is MICROWIRE compatible for simple interface to standard microcontrollers and microprocessors. There are 7 instructions that control these devices: Read, Erase/Write Enable, Erase, Erase All, Write, Write All, and Erase/Write Disable. The ready/busy status is available on the DO pin during programming.

#### Features

- 2.7V to 5.5V operation in all modes
- Typical active current of 100  $\mu$ A; Typical standby current of 1  $\mu$ A
- No erase required before write
- Reliable CMOS floating gate technology
- MICROWIRE compatible serial I/O
- Self-timed programming cycle
- Device status during programming mode
- 40 years data retention
- Endurance:  $10^6$  data changes
- Packages available: 8-pin SO, 8-pin DIP, and 8-pin TSSOP

#### Block Diagram

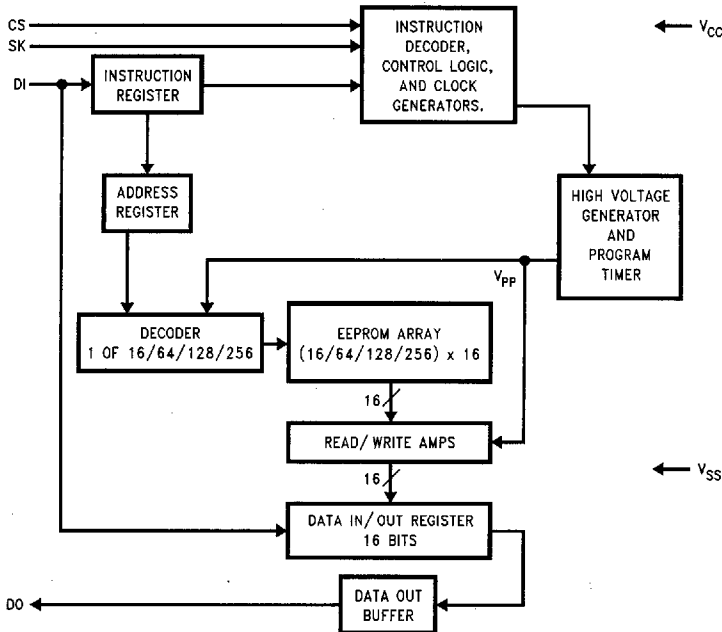

TL/D/10045-1

## Connection Diagrams

Dual-In-Line Package (N)  
8-Pin SO (M8) and 8-Pin TSSOP (MT8)

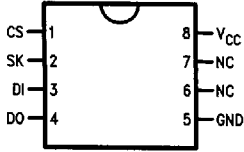

TL/D/10045-2

Pin Names

CS	Chip Select
SK	Serial Data Clock
DI	Serial Data Input
DO	Serial Data Output
GND	Ground
VCC	Power Supply

NS Package Number N08E, M08A or MTC08

## Ordering Information

### Commercial Temp. Range (0°C to +70°C)

Order Number
NM93C06LN/NM93C46LN
NM93C56LN/NM93C66LN
NM93C06LM8/NM93C46LM8
NM93C56LM8/NM93C66LM8
NM93C06LMT8/NM93C46LMT8
NM93C56LMT8/NM93C66LMT8

### Extended Temp. Range (-40°C to +85°C)

Order Number
NM93C06LEN/NM93C46LEN
NM93C56LEN/NM93C66LEN
NM93C06LEM8/NM93C46LEM8
NM93C56LEM8/NM93C66LEM8
NM93C06LEMT8/NM93C46LEMT8
NM93C56LEMT8/NM93C66LEMT8

### Automotive Temp. Range (-40°C to +125°C)

Order Number
NM93C06LVN/NM93C46LVN
NM93C56LVN/NM93C66TLVN
NM93C06LVM8/NM93C46LVM8
NM93C56LVM8/NM93C66LVM8
NM93C06LVMT8/NM93C46LVMT8
NM93C56LVMT8/NM93C66LVMT8

### Absolute Maximum Ratings (Note 1)

If Military/Aerospace specified devices are required, please contact the National Semiconductor Sales Office/Distributors for availability and specifications.

Ambient Storage Temperature	-65°C to +150°C
All Input or Output Voltages with Respect to Ground	+6.5V to -0.3V
Lead Temp. (Soldering, 10 sec.)	+300°C
ESD Rating	2000V

### Operating Conditions

Ambient Operating Temperature	0°C to +70°C
NM93C06L-NM93C66L	-40°C to +85°C
NM93C06LE-NM93C66LE	-40°C to +125°C
NM93C06LV-NM93C66LV	
Power Supply (V <sub>CC</sub> ) Range	2.7V to 5.5V

### DC and AC Electrical Characteristics: 2.7 V < V<sub>CC</sub> < 4.5V

Symbol	Parameter	Part Number	Conditions	Min	Max	Units
I <sub>CCA</sub>	Operating Current		CS = V <sub>IH</sub> , SK = 250 kHz		1	mA
I <sub>CCS</sub>	Standby Current		CS = V <sub>IL</sub>		10	μA
I <sub>IL</sub> I <sub>OL</sub>	Input Leakage Output Leakage		V <sub>IN</sub> = 0V to V <sub>CC</sub>		±1	μA
V <sub>IL</sub> V <sub>IH</sub>	Input Low Voltage Input High Voltage			-0.1 0.8 V <sub>CC</sub>	0.15 V <sub>CC</sub> V <sub>CC</sub> + 1	V
V <sub>OL</sub> V <sub>OH</sub>	Output Low Voltage Output High Voltage		I <sub>OL</sub> = 10 μA I <sub>OH</sub> = -10 μA	0.9 V <sub>CC</sub>	0.1 V <sub>CC</sub>	V
f <sub>SK</sub>	SK Clock Frequency			0	250	kHz
t <sub>SKH</sub>	SK High Time			1		μs
t <sub>SKL</sub>	SK Low Time			1		μs
t <sub>SKS</sub>	SK Setup Time		SK Must Be at V <sub>IL</sub> for t <sub>SKS</sub> before CS goes high	0.2		μs
t <sub>CS</sub>	Minimum CS Low Time		(Note 2)	1		μs
t <sub>CSS</sub>	CS Setup Time			0.2		μs
t <sub>DH</sub>	DO Hold Time			70		ns
t <sub>DIS</sub>	DI Setup Time			0.4		μs
t <sub>CSH</sub>	CS Hold Time			0		μs
t <sub>DIH</sub>	DI Hold Time			0.4		μs
t <sub>PD1</sub>	Output Delay to "1"				2	μs
t <sub>PD0</sub>	Output Delay to "0"				2	μs
t <sub>SV</sub>	CS to Status Valid				1	μs
t <sub>DF</sub>	CS to DO in TRI-STATE®		CS = V <sub>IL</sub>		0.4	μs
t <sub>WP</sub>	Write Cycle Time				15	ms

DC and AC Electrical Characteristics:  $4.5V < V_{CC} < 5.5V$ 

Symbol	Parameter	Part Number	Conditions	Min	Max	Units
I <sub>CCA</sub>	Operating Current		CS = V <sub>IH</sub> , SK = 1 MHz		1	mA
I <sub>CCS</sub>	Standby Current		CS = V <sub>IL</sub>		50	μA
I <sub>IL</sub> I <sub>OL</sub>	Input Leakage Output Leakage		V <sub>IN</sub> = 0V to V <sub>CC</sub> (Note 4)		±1	μA
V <sub>IL</sub> V <sub>IH</sub>	Input Low Voltage Input High Voltage			-0.1 2	0.8 V <sub>CC</sub> + 1	V
V <sub>OL1</sub> V <sub>OH1</sub>	Output Low Voltage Output High Voltage		I <sub>OL</sub> = 2.1 mA I <sub>OH</sub> = -400 μA	2.4	0.4	V
V <sub>OL2</sub> V <sub>OH2</sub>	Output Low Voltage Output High Voltage		I <sub>OL</sub> = 10 μA I <sub>OL</sub> = -10 μA	V <sub>CC</sub> - 0.2	0.2	V
f <sub>SK</sub>	SK Clock Frequency		(Note 5)	0	1	MHz
t <sub>SKH</sub>	SK High Time	NM93C06L-NM93C66L NM93C06LE-NM93C66LE		250 300		ns
t <sub>SKL</sub>	SK Low Time			250		ns
t <sub>SKS</sub>	SK Setup Time		SK Must Be at V <sub>IL</sub> for t <sub>SKS</sub> before CS goes high	50		ns
t <sub>CS</sub>	Minimum CS Low Time		(Note 2)	250		ns
t <sub>CSS</sub>	CS Setup Time			50		ns
t <sub>DH</sub>	DO Hold Time			70		ns
t <sub>DIS</sub>	DI Setup Time	NM93C06L-NM93C66L NM93C06LE-NM93C66LE		100 200		ns
t <sub>CSH</sub>	CS Hold Time			0		ns
t <sub>DIH</sub>	DI Hold Time			20		ns
t <sub>PD1</sub>	Output Delay to "1"				500	ns
t <sub>PD0</sub>	Output Delay to "0"				500	ns
t <sub>SV</sub>	CS to Status Valid				500	ns
t <sub>DF</sub>	CS to DO in TRI-STATE		CS = V <sub>IL</sub>		100	ns
t <sub>WP</sub>	Write Cycle Time				10	ms

## Capacitance (Note 3)

T<sub>A</sub> = 25°C, f = 1 MHz

Symbol	Test	Typ	Max	Units
C <sub>OUT</sub>	Output Capacitance		5	pF
C <sub>IN</sub>	Input Capacitance		5	pF

**Note 1:** Stress above those listed under "Absolute Maximum Ratings" may cause permanent damage to the device. This is a stress rating only and operation of the device at these or any other conditions above those indicated in the operational sections of the specification is not implied. Exposure to absolute maximum rating conditions for extended periods may affect device reliability.

**Note 2:** CS (Chip Select) must be brought low (to V<sub>IL</sub>) for an interval of t<sub>CS</sub> in order to reset all internal device registers (device reset) prior to beginning another opcode cycle (this is shown in the opcode diagrams in the following pages).

**Note 3:** This parameter is periodically sampled and not 100% tested.

**Note 4:** Typical leakage values are in the 20 nA range.

**Note 5:** The shortest allowable SK clock period = 1/f<sub>SK</sub> (as shown under the f<sub>SK</sub> parameter). Maximum SK clock speed (minimum SK period) is determined by the interaction of several AC parameters stated in the datasheet. Within this SK period, both t<sub>SKH</sub> and t<sub>SKL</sub> limits must be observed. Therefore, it is not allowable to set 1/f<sub>SK</sub> = t<sub>SKH</sub> (minimum) + t<sub>SKL</sub> (minimum) for shorter SK cycle time operation.

## AC Test Conditions

V <sub>CC</sub> Range	V <sub>IL</sub> /V <sub>IH</sub> Input Levels	V <sub>IL</sub> /V <sub>IH</sub> Timing Levels	V <sub>OL</sub> /V <sub>OH</sub> Timing Levels	I <sub>OL</sub> /I <sub>OH</sub>
2.7V ≤ V <sub>CC</sub> < 4.5V (Extended Voltage Levels)	0.3V/1.8V	1.0V	0.8V/1.5V	±10 μA
4.5V ≤ V <sub>CC</sub> ≤ 5.5V (TTL Levels)	0.4V/2.4V	1.0V/2.0V	0.4V/2.4V	-2.1 mA/0.4 mA

Output Load: 1 TTL Gate (C<sub>L</sub> = 100 pF)

## Functional Description

The NM93C06L/C46L/C56L/C66L device have 7 instructions as described below. Note that the MSB of any instruction is a "1" and is viewed as a start bit in the interface sequence. For the C06 and C46 the next 8 bits carry the op code and the 6-bit address for register selection. For the C56 and C66 the next 10-bits carry the op code and the 8-bit address for register selection.

### Read (READ):

The READ instruction outputs serial data on the DO pin. After a READ instruction is received, the instruction and address are decoded, followed by data transfer from the selected memory register into a 16-bit serial-out shift register. A dummy bit (logical 0) precedes the 16-bit data output string. Output data changes are initiated by a low to high transition of the SK clock.

### Erase/Write Enable (WEN):

When V<sub>CC</sub> is applied to the part, it powers up in the Erase/Write Disable (WDS) state. Therefore, all programming modes must be preceded by an Erase/Write Enable WEN

instruction. Once an Erase/Write Enable instruction is executed, programming remains enabled until an Erase/Write Disable (WDS) instruction is executed or V<sub>CC</sub> is completely removed from the part.

### Erase (ERASE):

The ERASE instruction will program all bits in the selected register to the logical "1" state. CS is brought low following the loading of the last address bit. This falling edge of the CS pin initiates the self-timed programming cycle.

The DO pin indicates the READY/BUSY status of the chip if CS is brought high after the t<sub>CS</sub> interval. DO = logical "0" indicates that programming is still in progress. DO = logical "1" indicates that the register, at the address specified in the instruction, has been erased, and the part is ready for another instruction.

## Functional Description (Continued)

### Write (WRITE):

The WRITE instruction is followed by 16 bits of data to be written into the specified address. After the last bit of data is put on the data-in (DI) pin, CS must be brought low before the next rising edge of the SK clock. This falling edge of CS initiates the self-timed programming cycle. The DO pin indicates the READY/BUSY status of the chip if CS is brought high after the  $t_{CS}$  interval. DO = logical 0 indicates that programming is still in progress. DO = logical 1 indicates that the register at the address specified in the instruction has been written with the data pattern specified in the instruction and the part is ready for another instruction.

### Erase All (ERAL):

The ERAL instruction will simultaneously program all registers in the memory array and set each bit to the logical "1"

**Note:** NSC CMOS EEPROMs do not require an "ERASE" or "ERASE ALL" operation prior to the "WRITE" and "WRITE ALL" instructions. The "ERASE" and "ERASE ALL" instructions are included to maintain compatibility with earlier technology EEPROMs.

state. The Erase All cycle is identical to the ERASE cycle except for the different op-code. As in the ERASE mode, the DO pin indicates the READY/BUSY status of the chip if CS is brought high after the  $t_{CS}$  interval.

### Write All (WRALL):

The WRALL instruction will simultaneously program all registers with the data pattern specified in the instruction. As in the WRITE mode, the DO pin indicates the READY/BUSY status of the chip if CS is brought high after the  $t_{CS}$  interval.

### Write Disable (WDS):

To protect against accidental data disturb, the WDS instruction disables all programming modes and should follow all programming operations. Execution of a READ instruction is independent of both the WEN and WDS instructions.

## Instruction Set for the NM93C06L and NM93C46L

Instruction	SB	Op Code	Address	Data	Comments
READ	1	10	A5-A0		Reads data stored in memory at specified address.
WEN	1	00	11XXXX		Enable all programming modes.
ERASE	1	11	A5-A0		Erase selected register.
WRITE	1	01	A5-A0	D15-D0	Writes selected register.
ERAL	1	00	10XXXX		Erases all registers.
WRALL	1	00	01XXXX	D15-D0	Writes all registers.
WDS	1	00	00XXXX		Disables all programming modes.

**Note:** Address bits A5 and A4 become "Don't Care" for the NM93C06L.

## Instruction Set for the NM93C56L and NM93C66L

Instruction	SB	Op Code	Address	Data	Comments
READ	1	10	A7-A0		Reads data stored in memory at specified address.
WEN	1	00	11XXXXXX		Enable all programming modes.
ERASE	1	11	A7-A0		Erase selected register.
WRITE	1	01	A7-A0	D15-D0	Writes selected register.
ERAL	1	00	10XXXXXX		Erases all registers.
WRALL	1	00	01XXXXXX	D15-D0	Writes all registers.
WDS	1	00	00XXXXXX		Disables all programming modes.

**Note:** Address bit A7 is "Don't Care" for the NM93C56L.

# Timing Diagrams

## Synchronous Data Timing

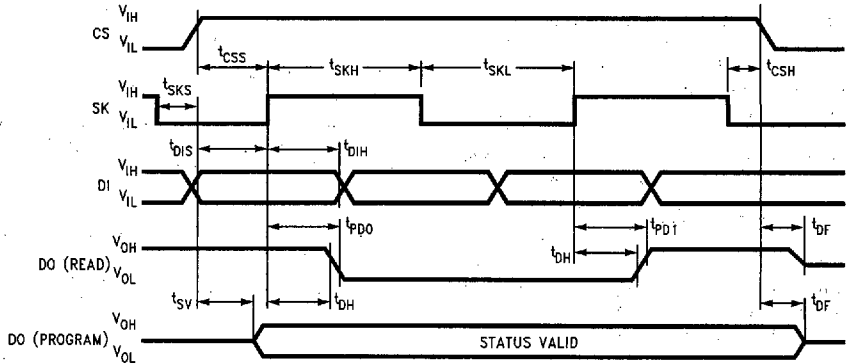

TL/D/10045-13

### READ

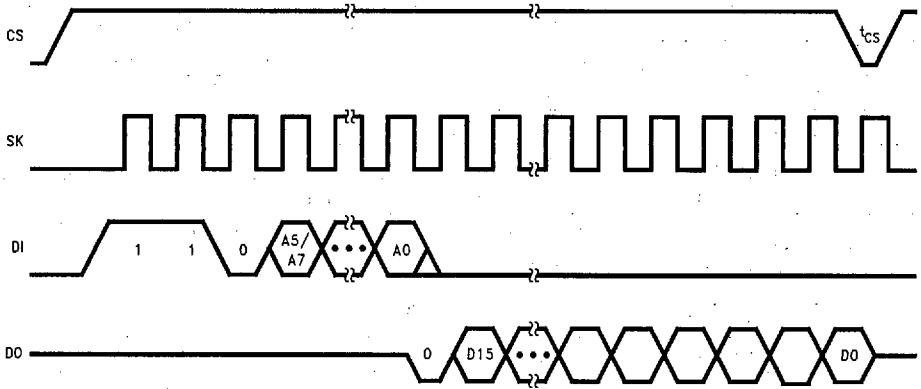

TL/D/10045-5

### WEN

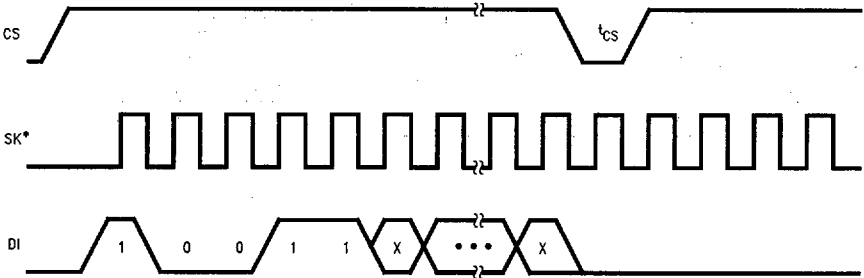

TL/D/10045-6

Timing Diagrams (Continued)

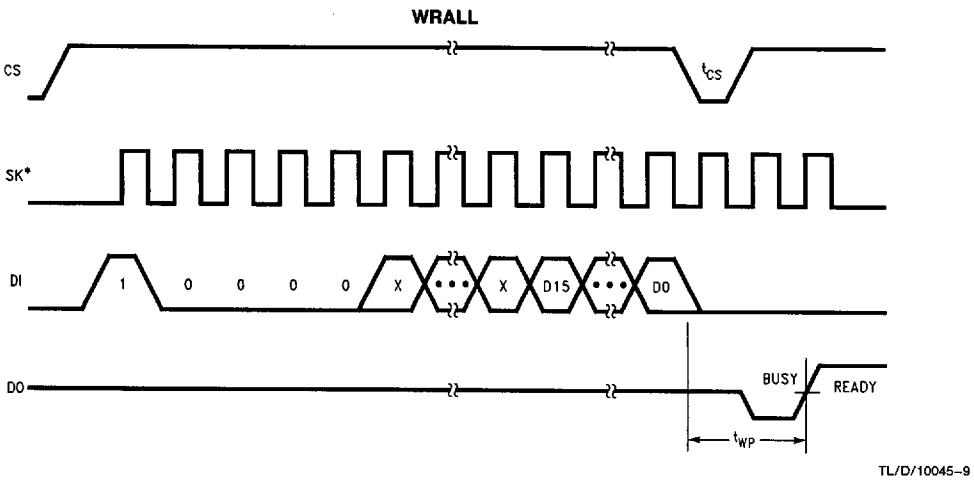
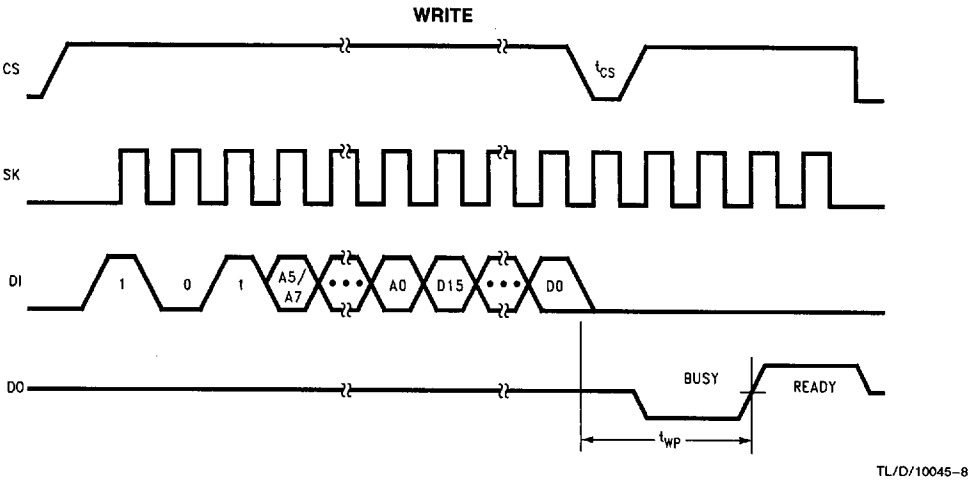
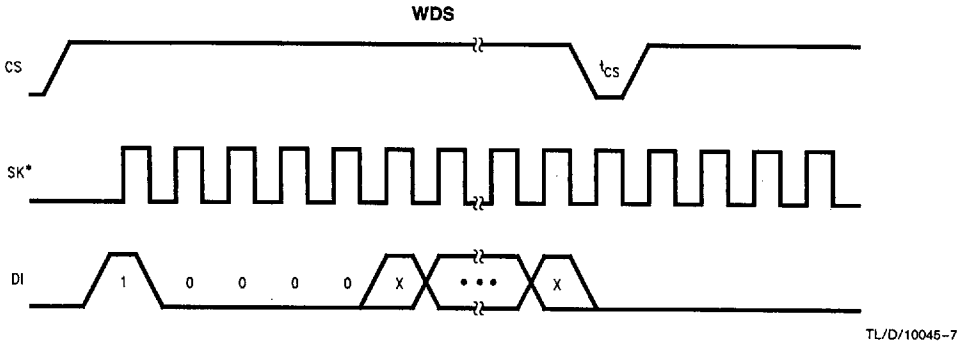



Timing Diagrams (Continued)

ERASE

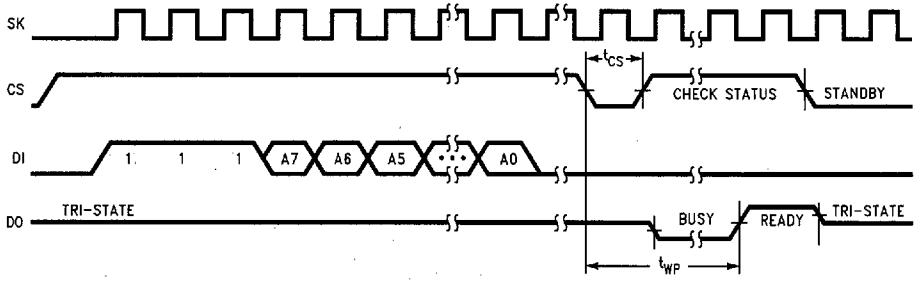

TL/D/10045-10

ERAL

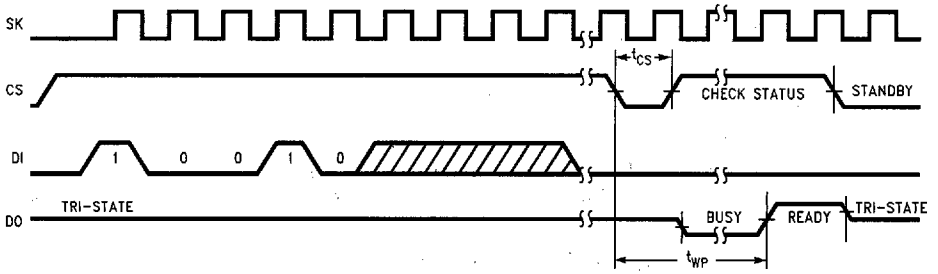

TL/D/10045-11