

**MOTOROLA
SEMICONDUCTOR
TECHNICAL DATA**

5

VOLTAGE REFERENCE FAMILY

The MC1404 series of ICs is a family of temperature-compensated voltage references for precision data conversion applications, such as A/D, D/A, V/F, and F/V. Advances in laser-trimming and ion-implanted devices, as well as monolithic fabrication techniques, make these devices stable and accurate to 12 bits over both military and commercial temperature ranges. In addition to excellent temperature stability, these parts offer excellent long-term stability and low noise.

- Output Voltages: Standard, 5.0 V, 6.25 V, 10 V
- Trimmable Output: > ±6%
- Wide Input Voltage Range: $V_{ref} + 2.5 V$ to 40 V
- Low Quiescent Current: 1.25 mA Typical
- Temperature Coefficient: 10 ppm/°C Typical
- Low Output Noise: 12 μV p-p Typical
- Excellent Ripple Rejection: > 80 dB Typical

TYPICAL APPLICATIONS

- Voltage Reference for 8 – 12 Bit D/A Converters
- Low T_C Zener Replacement
- High Stability Current Reference
- MPU D/A and A/D Applications

FIGURE 1 — VOLTAGE OUTPUT 8-BIT DAC USING MC1404U10

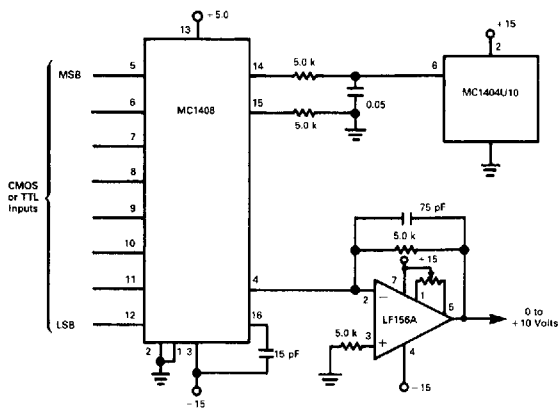

**MC1404
MC1404A
MC1504**

**PRECISION LOW DRIFT
VOLTAGE REFERENCES**

5.0, 6.25, and 10-VOLT OUTPUT VOLTAGES

LASER TRIMMED SILICON
MONOLITHIC INTEGRATED CIRCUIT

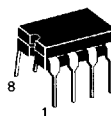

U SUFFIX
CERAMIC PACKAGE
CASE 693

PIN ASSIGNMENTS

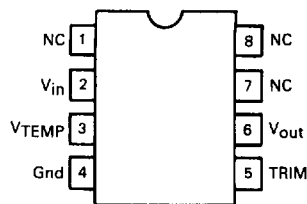

ORDERING INFORMATION

PACKAGE Ceramic DIP	
Device	Temperature Range
5.0 Volts	
MC1504U5	-55°C to +125°C
MC1404U5	0°C to +70°C
MC1404AU5	0°C to +70°C
6.25 Volts	
MC1504U6	-55°C to +125°C
MC1404U6	0°C to +70°C
MC1404AU6	0°C to +70°C
10 Volts	
MC1504U10	-55°C to +125°C
MC1404U10	0°C to +70°C
MC1404AU10	0°C to +70°C

MC1404,A, MC1504

MAXIMUM RATINGS

Rating	Symbol	Value	Unit
Input Voltage	V_{in}	40	V
Storage Temperature	T_{stg}	-65 to +150	°C
Junction Temperature	T_J	+175	°C
Operating Ambient Temperature Range MC1504 MC1404,A	T_A	-55 to +125 0 to +70	°C

ELECTRICAL CHARACTERISTICS ($V_{in} = 15$ Volts, $T_A = 25^\circ\text{C}$ and Trim Terminal not connected unless otherwise noted)

Characteristic	Symbol	MC1404,A			MC1504			Unit
		Min	Typ	Max	Min	Typ	Max	
Output Voltage ($I_O = 0$ mA) MC1404U5, AU5/MC1504U5 MC1404U6, AU6/MC1504U6 MC1404U10, AU10/MC1504U10	V_O	4.95 6.19 9.9	5.0 6.25 10	5.05 6.31 10.1	4.95 6.19 9.9	5.0 6.25 10	5.05 6.31 10.1	Volt
Output Voltage Tolerance	—	—	± 0.1	± 1.0	—	± 0.1	± 1.0	%
Output Trim Range (Figure 10) ($R_p = 100$ k Ω)	ΔV_{TRIM}	± 6.0	—	—	± 6.0	—	—	%
Output Voltage Temperature Coefficient, Over Full Temperature Range MC1404, MC1504 MC1404A	$\Delta V_O/\Delta T$	— —	10 10	40 25	— —	— —	55 —	ppm/°C
Maximum Output Voltage Change Over Temperature Range MC1404U5, MC1504U5 MC1404AU5 MC1404U6, MC1504U6 MC1404AU6 MC1404U10, MC1504U10 MC1404AU10	ΔV_O	— — — — —	— — — — —	14 9.0 17.5 11 28 18	— — — — — —	— — — — — —	50 — 62 — 99 —	mV
Line Regulation (1) ($V_{in} = V_{out} + 2.5$ V to 40 V, $I_{out} = 0$ mA)	Reg _{line}	—	2.0	6.0	—	2.0	6.0	mV
Load Regulation (1) ($0 \leq I_O \leq 10$ mA)	Reg _{load}	—	—	10	—	—	10	mV
Quiescent Current ($I_O = 0$ mA)	I_Q	—	1.2	1.5	—	1.2	1.5	mA
Short Circuit Current	I_{sc}	—	20	45	—	—	45	mA
Long Term Stability	—	—	25	—	—	25	—	ppm/1000 hrs

Note 1: Includes thermal effects.

DYNAMIC CHARACTERISTICS ($V_{in} = 15$ V, $T_A = 25^\circ\text{C}$ all voltage ranges unless otherwise noted)

Characteristic	Symbol	MC1404,A			MC1504			Unit
		Min	Typ	Max	Min	Typ	Max	
Turn-On Settling Time (to $\pm 0.01\%$)	t_S	—	50	—	—	50	—	μs
Output Noise Voltage — P to P (Bandwidth 0.1 to 10 Hz)	V_n	—	12	—	—	12	—	μV
Small-Signal Output Impedance 120 Hz 500 Hz	r_o	— —	0.15 0.2	— —	— —	0.15 0.2	— —	Ω
Power Supply Rejection Ratio	PSRR	70	80	—	70	80	—	dB

TYPICAL CHARACTERISTICS

FIGURE 2 – SIMPLIFIED DEVICE DIAGRAM

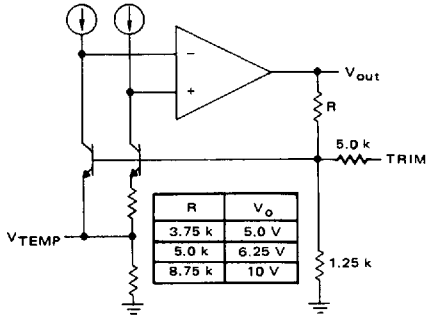

FIGURE 4 – OUTPUT VOLTAGE versus TEMPERATURE
 MC1404U10

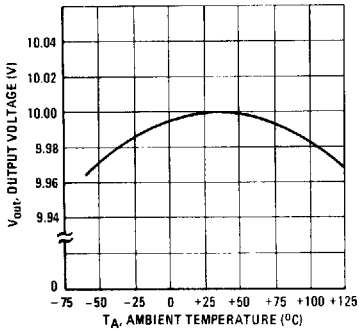

FIGURE 3 – LINE REGULATION versus TEMPERATURE

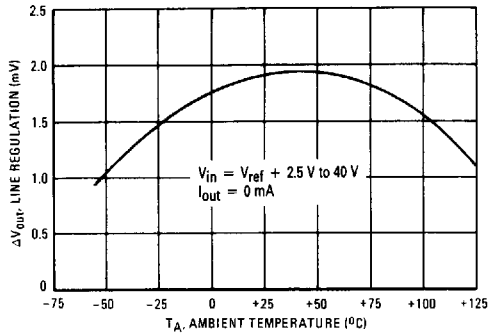

FIGURE 5 – LOAD REGULATION versus TEMPERATURE

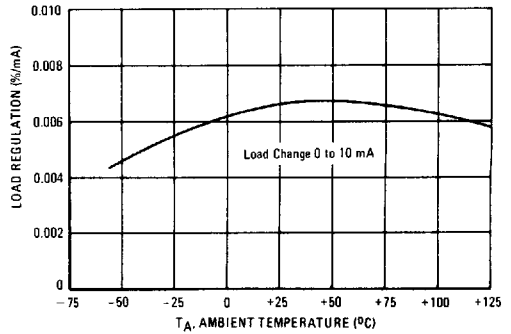

FIGURE 6 – POWER SUPPLY REJECTION RATIO
 versus FREQUENCY

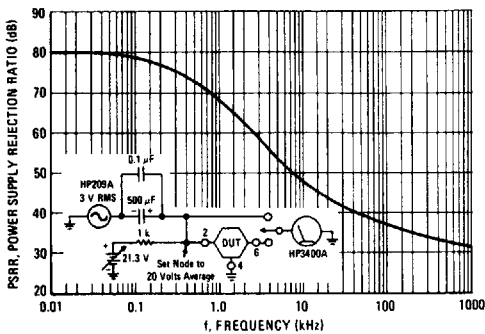
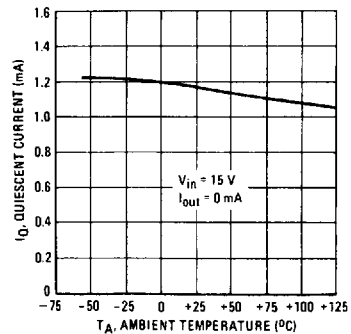

FIGURE 7 – QUIESCENT CURRENT versus TEMPERATURE



MC1404,A, MC1504

FIGURE 8 – SHORT CIRCUIT CURRENT versus TEMPERATURE

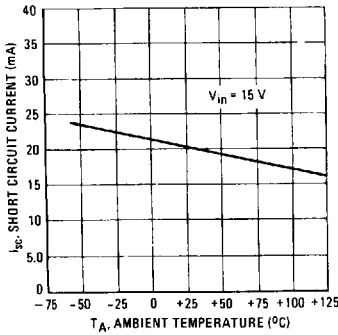

FIGURE 9 – V_{TEMP} OUTPUT versus TEMPERATURE

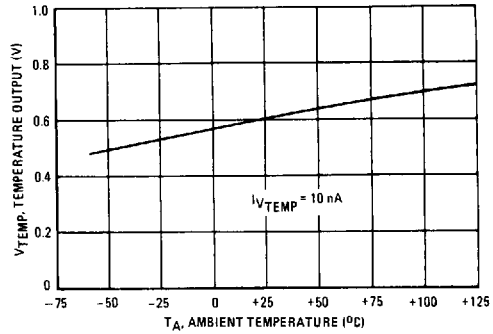
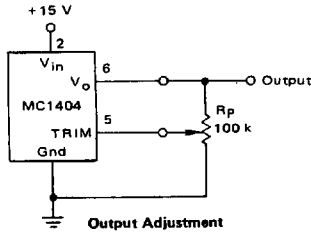

FIGURE 10 – OUTPUT TRIM CONFIGURATION



The MC1404 trim terminal can be used to adjust the output voltage over a ±6% range. For example, the output can be set to 10.000 V or to 10.240 V for binary applications. For trimming, Bourns type 3D59, 100 kΩ or 200 kΩ trimpot is recommended.

Although Figure 10 illustrates a wide trim range, temperature coefficients may become unpredictable for trim > ±6.0%.

FIGURE 11 – PRECISION SUPPLY USING MC1404

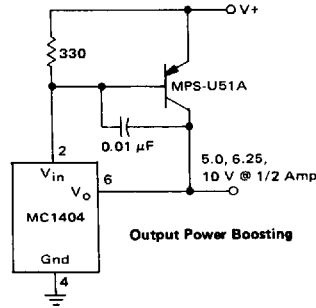

The addition of a power transistor, a resistor, and a capacitor converts the MC1404 into a precision supply with one ampere current capability. At V₊ = 15 V, the MC1404 can carry in excess of 14 mA of load current with good regulation. If the power transistor current gain exceeds 75, a one ampere supply can be realized.

FIGURE 12 – ULTRA STABLE REFERENCE FOR MC1723 VOLTAGE REGULATOR

