

8K x 9 Static RAM
Features

- **High speed**
— $t_{AA} = 25$ ns
- **9-bit organization is ideal for cache memory applications**
- **CMOS for optimum speed/power**
- **Low active power**
— 770 mW
- **Low standby power**
— 195 mW
- **TTL-compatible inputs and outputs**
- **Automatic power-down when deselected**
- **Easy memory expansion with \overline{CE}_1 , CE_2 , \overline{OE} options**

Functional Description

The CY7C182 is a high-speed CMOS static RAM organized as 8,192 by 9 bits and it is manufactured using Cypress's high-performance CMOS technology. Access times as fast as 25 ns are available with maximum power consumption of only 770 mW.

The CY7C182, which is oriented toward cache memory applications, features fully static operation requiring no external clocks or timing strobes. The automatic power-down feature reduces the power consumption by more than 70% when the circuit is deselected. Easy memory expansion is provided by an active-LOW chip enable (\overline{CE}_1), an active HIGH chip enable (CE_2), an active-LOW output enable (\overline{OE}), and three-state drivers.

An active-LOW write enable signal (\overline{WE}) controls the writing/reading operation of

the memory. When \overline{CE}_1 and \overline{WE} inputs are both LOW, data on the nine data input/output pins (I/O_0 through I/O_8) is written into the memory location addressed by the address present on the address pins (A_0 through A_{12}). Reading the device is accomplished by selecting the device and enabling the outputs, (\overline{CE}_1 and \overline{OE} active LOW and CE_2 active HIGH), while (\overline{WE}) remains inactive or HIGH. Under these conditions, the contents of the location addressed by the information on address pins is present on the nine data input/output pins.

The input/output pins remain in a high-impedance state unless the chip is selected, outputs are enabled, and write enable (\overline{WE}) is HIGH.

A die coat is used to ensure alpha immunity.

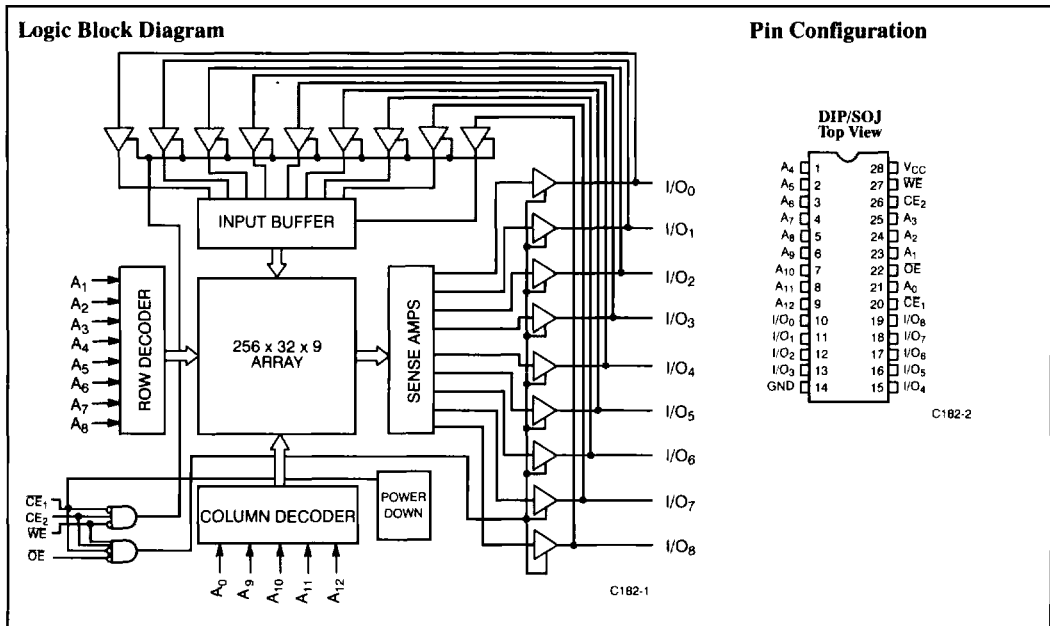
Selection Guide

	7C182-20	7C182-25	7C182-35	7C182-45
Maximum Access Time (ns)	20	25	35	45
Maximum Operating Current (mA)	150	140	140	140
Maximum Standby Current (mA)	35	35	35	35

Shaded area contains preliminary information.

Maximum Ratings

(Above which the useful life may be impaired. For user guidelines, not tested.)

Storage Temperature	-65°C to +150°C
Ambient Temperature with Power Applied	-55°C to +125°C
Supply Voltage to Ground Potential ^[1]	-0.5V to +7.0V
DC Voltage Applied to Outputs in High Z State ^[1]	-0.5V to +7.0V
DC Input Voltage ^[1]	-0.5V to +7.0V

Output Current into Outputs (LOW)	20 mA
Static Discharge Voltage (per MIL-STD-883, Method 3015.2)	>2001V
Latch-Up Current	>200 mA

Operating Range

Range	Ambient Temperature	V _{CC}
Commercial	0°C to +70°C	5V ± 10%

2
Electrical Characteristics Over the Operating Range

Parameter	Description	Test Conditions	7C182-20		7C182-25, 35, 45		Unit
			Min.	Max.	Min.	Max.	
V _{OH}	Output HIGH Voltage	V _{CC} Min., I _{OH} = -4.0 mA.	2.4		2.4		V
V _{OL}	Output LOW Voltage	V _{CC} Min., I _{OL} = 8.0 mA		0.4		0.4	V
V _{IH}	Input HIGH Voltage		2.2	V _{CC}	2.2	V _{CC}	V
V _{IL}	Input LOW Voltage ^[1]		-0.5	0.8	-0.5	0.8	V
I _{Ix}	Input Load Current	GND ≤ V _{IN} ≤ V _{CC} , GND < V _{OUT} < V _{CC} , Output Disabled	-10	+10	-10	+10	μA
I _{OZ}	Output Leakage Current	V _{CC} = Max., V _{OUT} = GND	-10	+10	-10	+10	μA
I _{OS}	Output Short Circuit Current ^[2]	V _{CC} = Max., V _{OUT} = GND		-300		-300	mA
I _{CC}	V _{CC} Operating Circuit Current	V _{CC} Max., Output Current = 0 mA, f = Max., V _{IN} = V _{CC} or GND		150		140	mA
I _{SB1}	Automatic Power-Down Current — TTL Inputs	Max V _{CC} , CE ₁ ≥ V _{IH} , CE ₂ ≤ V _{IL} , V _{IN} ≥ V _{IH} or V _{IN} ≤ V _{IL} , f = f _{MAX}		35		35	mA
I _{SB2}	Automatic Power-Down Current — CMOS Inputs	Max V _{CC} , CE ₁ ≥ V _{CC} - 0.3V, CE ₂ ≤ 0.3V, V _{IN} ≥ V _{CC} - 0.3V or V _{IN} ≤ 0.3V, f = 0		20		20	mA

Shaded area contains preliminary information.

Capacitance^[3]

Parameter	Description	Test Conditions	Max.	Unit
C _{OUT}	Output Capacitance	T _A = 25°C, f = 1 MHz, V _{CC} = 5.0V	10	pF
C _{IN}	Input Capacitance		10	pF

Notes:

- V_{IL} (min.) = -3.0V for pulse durations of less than 20 ns.
- Duration of the short circuit should not exceed 30 seconds. Not more than one output should be shorted at one time.
- Tested initially and after any design or process changes that may affect these parameters.

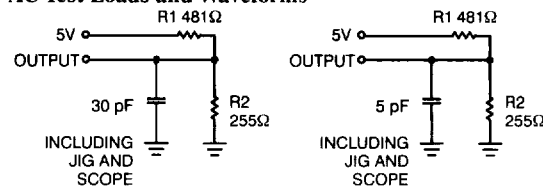
AC Test Loads and Waveforms

C182-3

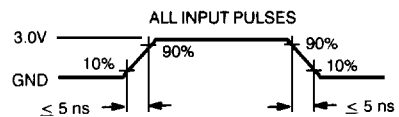

C182-4

Equivalent to: THÉVENIN EQUIVALENT

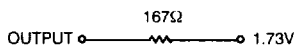

Switching Characteristics Over the Operating Range

Parameter	Description	7C182-20		7C182-25		7C182-35		7C182-45		Unit
		Min.	Max.	Min.	Max.	Min.	Max.	Min.	Max.	
READ CYCLE^[4]										
t_{RC}	Read Cycle Time	20		25		35		45		ns
t_{AA}	Address to Data Valid		20		25		35		45	ns
t_{OHA}	Data Hold from Address Change	3		3		3		3		ns
t_{ACE1}	\overline{CE}_1 Access Time		20		25		35		45	ns
t_{ACE2}	CE_2 Access Time		20		25		35		45	ns
t_{LZCE1}	\overline{CE}_1 LOW to Low Z	5		5		5		5		ns
t_{LZCE2}	CE_2 HIGH to Low Z	5		5		5		5		ns
t_{HZCE1}	\overline{CE}_1 HIGH to High Z ^[5]		15		18		20		25	ns
t_{HZCE2}	CE_2 LOW to High Z ^[5]		15		18		20		25	ns
t_{PU}	\overline{CE}_1 LOW to Power-Up	0		0		0		0		ns
t_{PD}	\overline{CE}_1 HIGH to Power-Down		20		20		20		25	ns
t_{DOE}	\overline{OE} Access Time		15		18		20		20	ns
t_{LZOE}	\overline{OE} LOW to Low Z	3		3		3		3		ns
t_{HZOE}	\overline{OE} HIGH to High Z ^[5]		15		18		20		25	ns
WRITE CYCLE^[6]										
t_{WC}	Write Cycle Time	20		25		35		45		ns
t_{SA}	Address Set-Up Time	0		0		0		0		ns
t_{AW}	Address Valid to End of Write	15		20		30		40		ns
t_{SD}	Data Set-Up Time	10		15		20		25		ns
t_{SCE1}	\overline{CE}_1 LOW to Write End	15		20		30		40		ns
t_{SCE2}	CE_2 HIGH to Write End	15		20		30		40		ns
t_{PWE}	\overline{WE} Pulse Width	15		20		25		30		ns
t_{HA}	Address Hold from End of Write	0		0		0		0		ns
t_{HD}	Data Hold Time	0		0		0		0		ns
t_{LZWE}	Write HIGH to Low Z ^[7]	3		3		3		3		ns
t_{HZWE}	Write LOW to High Z ^[5, 7, 8]		13		13		15		20	ns

Shaded area contains preliminary information.

Notes:

- \overline{WE} is HIGH for read cycle.
- t_{HZCE} and t_{HZWE} are specified with $C_L = 5$ pF. Transition is measured ± 500 mV from steady-state voltage.
- The internal write time of the memory is defined by the overlap of \overline{CE}_1 LOW, CE_2 HIGH, and \overline{WE} LOW. All three signals must be asserted to initiate a write and any signal can terminate a write by being deasserted. The data input set-up and hold timing should be referenced to the rising edge of the signal that terminates the write.
- At any given temperature and voltage condition, t_{LZWE} is less than t_{HZWE} for any given device. These parameters are sampled and not 100% tested.
- Address valid prior to or coincident with \overline{CE} transition LOW and CE_2 transition HIGH.

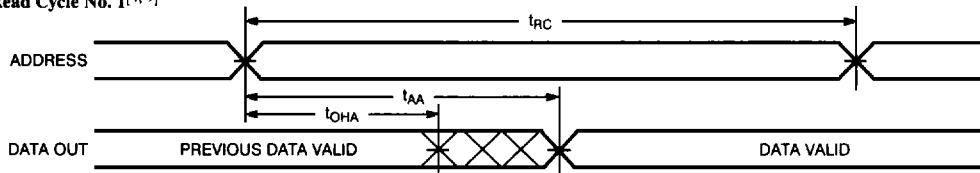
Switching Waveforms
Read Cycle No. 1^[4, 9]

C182-5

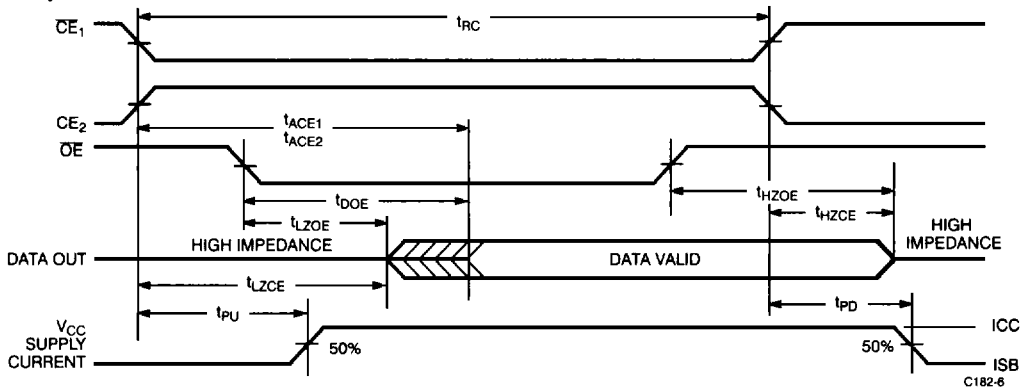
Read Cycle No. 2^[4, 10]

C182-6

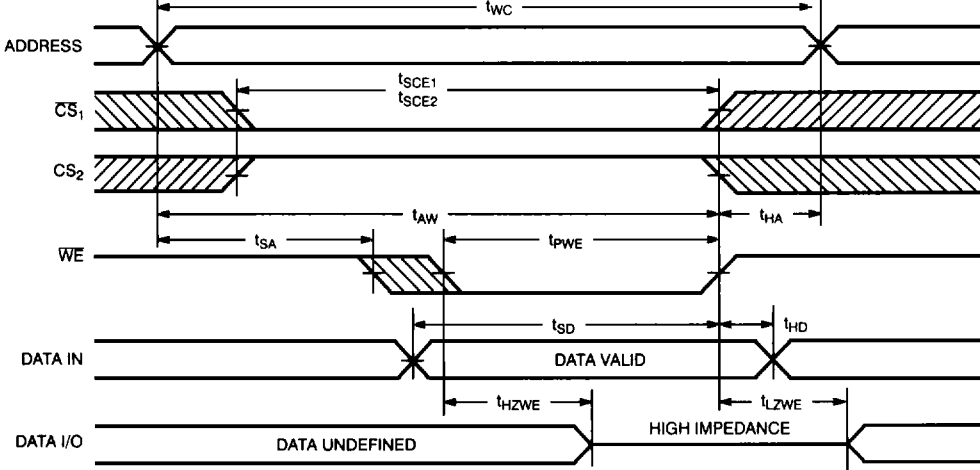
Write Cycle No. 1 (WE Controlled)^[6]

C182-7

Notes:

 9. Device is continuously selected. \overline{OE} , $\overline{CE}_1 = V_{IL}$. $\overline{CE}_2 = V_{IH}$.

 10. If \overline{CE}_1 goes HIGH and \overline{CE}_2 goes LOW simultaneously with WE HIGH, the output remains in a high-impedance state.

Switching Waveforms (continued)

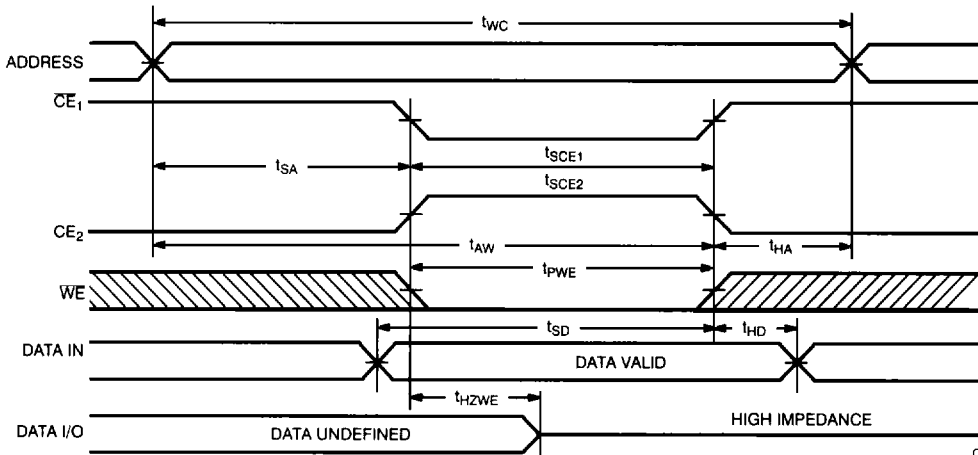
Write Cycle No. 2 (CE Controlled)^(6, 10)

C182-8

Truth Table

CE ₁	CE ₂	OE	WE	Data In	Data Out	Mode
H	X	X	X	Z	Z	Deselect/Power-Down
L	H	L	H	Z	Valid	Read
L	H	X	L	Valid	Z	Write
L	H	H	H	Z	Z	Output Disable
X	L	X	X	Z	Z	Deselect

Ordering Information

Speed (ns)	Ordering Code	Package Name	Package Type	Operating Range
20	CY7C182-20PC	P21	28-Lead (300-Mil) Molded DIP	Commercial
	CY7C182-20VC	V21	28-Lead Molded SOJ	
25	CY7C182-25PC	P21	28-Lead (300-Mil) Molded DIP	Commercial
	CY7C182-25VC	V21	28-Lead Molded SOJ	
35	CY7C182-35PC	P21	28-Lead (300-Mil) Molded DIP	Commercial
	CY7C182-35VC	V21	28-Lead Molded SOJ	
45	CY7C182-45PC	P21	28-Lead (300-Mil) Molded DIP	Commercial
	CY7C182-45VC	V21	28-Lead Molded SOJ	

Shaded area contains preliminary information.

Document #: 38-00110-E