

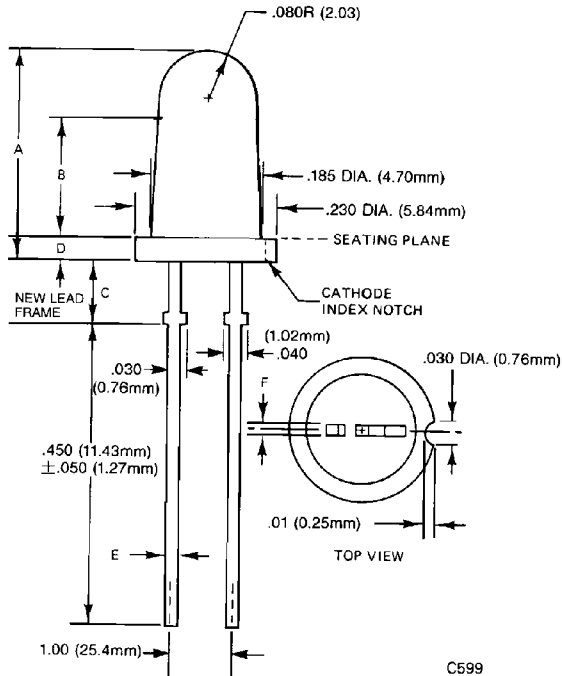

TAPERED PACKAGE T-1 $\frac{3}{4}$ SOLID STATE LAMPS

STANDARD RED MV502XA

PACKAGE DIMENSIONS



DESCRIPTION

The MV502X Series of solid state indicators is made with gallium arsenide phosphide light emitting diodes. Encapsulation and lens is epoxy. Various lens effects are available for many indicator applications.

FEATURES

- Tapered barrel T-1 $\frac{3}{4}$
- High Intensity Red light source with various lens colors and effects
- T-1 $\frac{3}{4}$ with stand-off
- Versatile mounting on PC board or panel
- Snap in panel mounting clip available (See MP22 for clip detail)

PHYSICAL CHARACTERISTICS

TYPE	A	B	C	D	E & F	SOURCE COLOR	LENS COLOR	LENS EFFECT	POP-IN MOUNTING	CIRCUIT BOARD MOUNTING
MV5021A	.340	.190	.100	.040	.020	Red	White Diffused	Soft	X	X
MV5022A	.340	.190	.100	.040	.020	Red	Transparent Red	Point	X	X
MV5023A	.340	.190	.100	.040	.020	Red	Red Diffused	Soft	X	X
MV5024A	.340	.160	.130	.040	.020	Red	Red Diffused	Soft	X	X
MV5025A	.340	.160	.130	.040	.020	Red	Red Diffused	Flooded	X	X
MV5026A	.340	.160	.130	.040	.020	Red	Dark Red Diffused	Flooded	X	X



**TAPERED PACKAGE T-1^{3/4}
SOLID STATE LAMPS**

ELECTRO-OPTICAL CHARACTERISTICS (25°C Free Air Temperature Unless Otherwise Specified)									
PARAMETER	TEST CONDITIONS		UNITS	5021A	5022A	5023A	5024A	5025A	5026A
Luminous Intensity	min.	$I_f=20\text{ mA}$	mcd	0.5	0.6	0.4	0.9	0.1	0.1
	typ.	$I_f=20\text{ mA}$	mcd	1.6	1.6	1.6	3.0	0.4	0.6
Peak wavelength	$I_f=20\text{ mA}$		nm	660	660	660	660	660	660
Spectral line half width	$I_f=20\text{ mA}$		nm	20	20	20	20	20	20
Forward voltage V_f	typ.	$I_f=20\text{ mA}$	V	1.65	1.65	1.65	1.65	1.65	1.65
	max.	$I_f=20\text{ mA}$	V	2.0	2.0	2.0	2.0	2.0	2.0
Reverse current I_R	max.	$V_R=5.0\text{V}$	μA	100	100	100	100	100	100
Reverse voltage V_R	min.	$I_R=100\ \mu\text{A}$	V	5.0	5.0	5.0	5.0	5.0	5.0
Capacitance	typ.	$V=0$	pF	35	35	35	35	35	35
Viewing angle	Between 50% Points		degrees	90	90	90	60	180	90
Rise time and fall time	10%-90% 50 Ω system		nsec	50	50	50	50	50	50
	typ. 90%-10% 50 Ω system		nsec	50	50	50	50	50	50

ABSOLUTE MAXIMUM RATINGS	
Power dissipation at 25°C ambient	180 mW
Derate linearly from 25°C	2 mW/°C
Storage and operating temperatures	-55°C to +100°C
Lead soldering time at 260°C (See Note 1)	5 sec.
Continuous forward current at 25°C	100 mA
Peak forward current (1 μsec pulse, 0.3% duty cycle)	1.0 A
Reverse voltage	5.0 V

NOTES
1. The leads of the device were immersed in molten solder at 260°C to a point 1/16 inch (1.6 mm) from the body of the device per MIL-S-750, with a dwell time of 5 seconds.

TYPICAL ELECTRO-OPTICAL CHARACTERISTIC CURVES

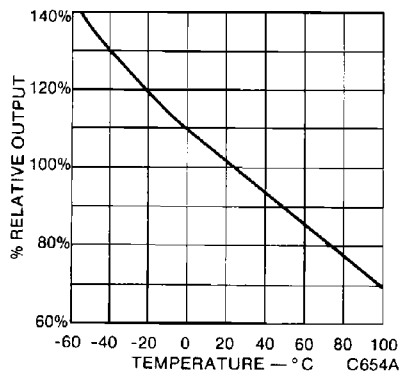

Fig. 1. Output vs. Temperature

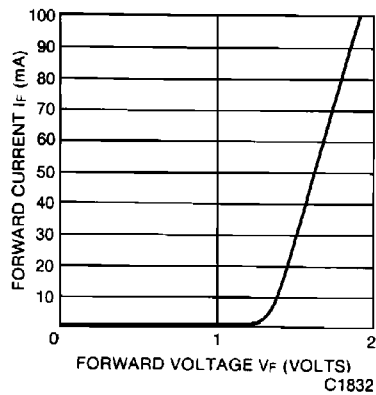

Fig. 2. Forward Current vs. Forward Voltage

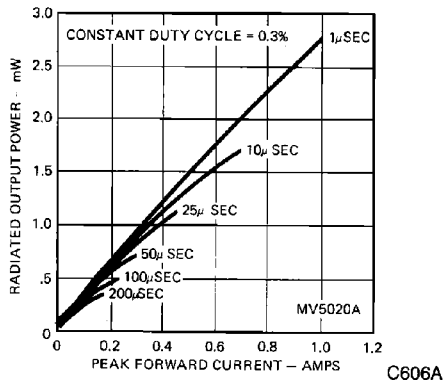

Fig. 3. Radiated Output Power vs. Peak Forward Current

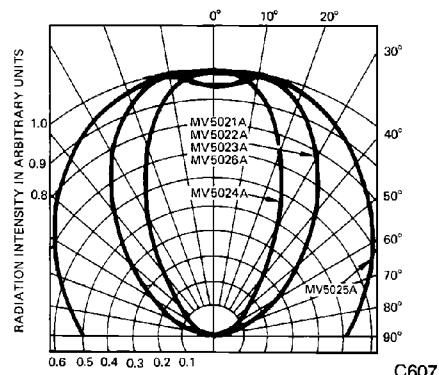

Fig. 4. Spatial Distribution

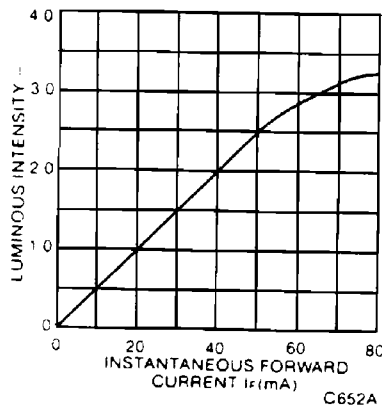

Fig. 5. Luminous Intensity vs. Forward Current