

FAN4041

Precision Micropower Shunt Voltage Reference

Features

- Adjustable shunt reference
- Tolerances to $\pm 0.5\%$ (25°C)
- Low output noise
- Low temperature coefficient to $100\text{ ppm}/^{\circ}\text{C}$ max
- Small packages
- Extended operating current range

Applications

- Portable equipment
- Disk drives
- Instrumentation
- Audio equipment
- Data acquisition systems

Description

The FAN4041 adjustable precision shunt references are ideal for space- and cost-sensitive applications. They are available with output voltage tolerances of 0.5% and 1%. They also have excellent temperature coefficients, to $100\text{ ppm}/^{\circ}\text{C}$ for the tighter tolerance grades. The FAN4041 series has an extended operating current range, sinking as much as 25mA.

The FAN4041 series is available in SOT-23 and TO-92 packages.

Connection Diagrams

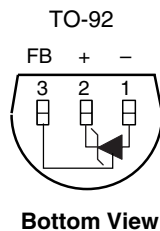
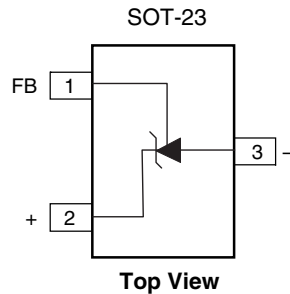

Absolute Maximum Ratings¹

Ratings are over full operating free-air temperature range unless otherwise noted.

Parameter	Min.	Max.	Unit
Continuous cathode current, I_K	-30	30	mA
Power dissipation	See Dissipation Rating Table		
Maximum Output Voltage		12	V
Storage Temperature Range	-65	150	°C
Lead Temperature (Soldering, 10 sec.)		300	°C

Notes:

- Functional operation under these conditions is not implied. Permanent damage may occur if the device is subjected to conditions outside these ratings.

Recommended Operating Conditions

Parameter	Min.	Max.	Unit
Continuous cathode current, I_K	0.07	25	mA
Operating temperature range in free air, T_A	-40	85	°C
Output Voltage Range	1.24	10	V

Dissipation Rating Table

Package	Power Rating $T_A \leq 25^\circ\text{C}$	Derating Factor $T_A \geq 25^\circ\text{C}$	Power Rating $T_A = 70^\circ\text{C}$
TO-92	550mW	5.5mW/°C	302mW
SOT23	306mW	3.0mW/°C	168mW

Equivalent Schematic

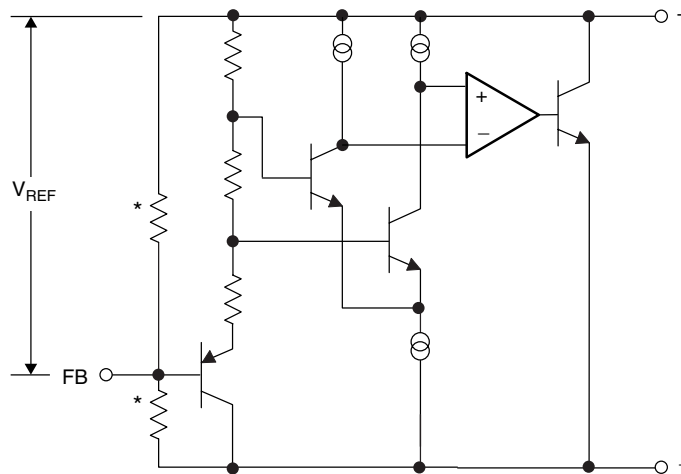

*External adjust components.

Guaranteed Electrical Characteristics, FAN4041

($T_A = 25^\circ\text{C}$ unless otherwise specified, in free air)

The • denotes specifications which apply over the full operating temperature range.

Symbol	Parameter	Conditions	Limits		Units
			C	D	
V_{REF}	Reference Voltage	$I_K = 100\mu\text{A}$, $V_{OUT} = 5\text{V}$	1.220	1.220	V*
TCV_{Ref}	Reference Voltage Tolerance	$I_K = 100\mu\text{A}$, $V_{OUT} = 5\text{V}$	± 6.2 ± 14	± 12 ± 24	mV mV
I_{RMIN}	Minimum Operating Current		• 65	70	μA
$\Delta V_{REF}/\Delta T$	Reference Voltage Temperature Coefficient	$I_K = 1\text{mA}$	• ± 100	± 150	ppm/ $^\circ\text{C}$
$\Delta V_{REF}/\Delta I_K$	Reference Voltage Change with Operating Current	$I_{RMIN} \leq I_K \leq 1\text{mA}$ $1\text{mA} \leq I_K \leq 12\text{mA}$ $1\text{mA} \leq I_K \leq 25\text{mA}$	• 2.0 • 8 12	2.5 10 15	mV mV mV*
$\Delta V_{REF}/\Delta V_O$	Reference Voltage Change with Output Voltage	$I_K = 1\text{mA}$	• -2.5	-3.0	mV/V
I_{FB}	Feedback Current		• 120	200	nA
Z_{KA}	Reverse Dynamic Impedance	$I_K = 1\text{mA}$, $f = 120\text{Hz}$, $I_{AC} = 0.1I_K$ $V_{OUT} = V_{REF}$ $V_{OUT} = 10\text{V}$	0.3 2	0.3 2	Ω^* Ω^*
e_N	Wideband Noise	$I_K = 100\mu\text{A}$, $V_{OUT} = V_{REF}$ $10\text{Hz} \leq f \leq 10\text{kHz}$	20	20	μV_{RMS}^*
ΔV_{REF}	Reference Voltage Long-term Stability	$t = 1000\text{hrs}$, $T = 25^\circ\text{C}$, $I_K = 100\mu\text{A}$	120	120	ppm*

*Typical.

Applications Information

The FAN4041 is a precision micro-power curvature-corrected bandgap shunt voltage reference. For space critical applications, the FAN4041 is available in the sub-miniature SOT-23 package. The FAN4041 has been designed for stable operation without the need of an external capacitor connected between the “+” pin and the “-” pin. If, however, a bypass capacitor is used, the FAN4041 remains stable. The minimum operating current is 65µA for the FAN4041.

In a conventional shunt regulator application (Figure 1), an external series resistor (R_S) is connected between the supply voltage and the FAN4041. R_S determines the current that flows through the load (I_L) and the FAN4041 (I_Q). Since load current and supply voltage may vary, R_S should be small enough to supply at least the minimum acceptable I_Q to the FAN4041 even when the supply voltage is at its minimum and the load current is at its maximum value. When the supply voltage is at its maximum and I_L is at its minimum, R_S should be large enough so that the current flowing through the FAN4041 is less than 25 mA.

R_S should be selected based on the supply voltage, (V_S), the desired load and operating current, (I_L and I_Q), and the FAN4041’s reverse breakdown voltage, V_R .

$$R_S = \frac{V_S - V_R}{I_L - I_Q}$$

The FAN4041 output voltage can be adjusted to any value in the range of 1.220V through 10V. It is a function of the internal reference voltage (V_{REF}) and the ratio of the external feedback resistors as shown in Figure 2. The output voltage is found using the equation

$$V_O = V_{REF} \left[\left(\frac{R_2}{R_1} \right) + 1 \right] \quad (1)$$

where V_O is the output voltage. The actual value of the internal V_{REF} is a function of V_O . The “corrected” V_{REF} is determined by

$$V_{REF} = \Delta V_O \left(\frac{\Delta V_{REF}}{\Delta V_O} \right) + V_Y \quad (2)$$

where

$$V_Y = 1.220V \text{ and } \Delta V_O = V_O - V_Y$$

$\Delta V_{REF}/\Delta V_O$ is found in the Electrical Characteristics and is -2.5mV/V for the C-grade. You can get a more accurate indication of the output voltage by replacing the value of V_{REF} in equation (1) with the value found using equation (2). Note that the actual output voltage can deviate from that predicted using the typical value of $\Delta V_{REF}/\Delta V_O$ in equation (2): for C-grade parts, the worst-case $\Delta V_{REF}/\Delta V_O$ is -2.5mV/V. For D-grade parts, the worst-case $\Delta V_{REF}/\Delta V_O$ is -3.0mV/V.

Typical Applications

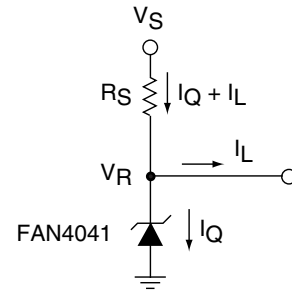

Figure 1. Shunt Regulator

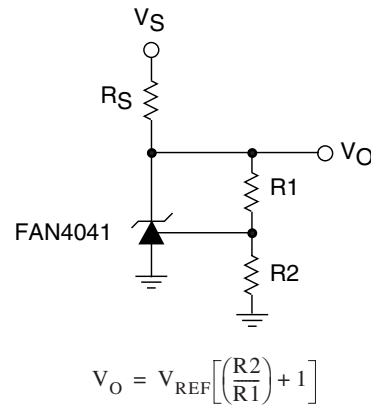

Figure 2. Adjustable Shunt Regulator

Mechanical Dimensions

TO-92 Package

Symbol	Inches		Millimeters		Notes
	Min.	Max.	Min.	Max.	
A	.170	.210	4.32	5.33	
b	.015	.021	.38	.53	
c	.014	.020	.36	.51	
øD	.175	.205	4.45	5.21	
E	.125	.165	3.18	4.19	
e	.095	.105	2.41	2.67	
e1	.045	.055	1.14	1.40	
L	.500	—	12.70	—	
S	.080	.115	2.03	2.92	
α	4°	6°	4°	6°	

Notes:

1. Package outline exclusive of any mold flashes dimension.
2. Package outline exclusive of burr dimension.

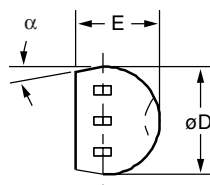
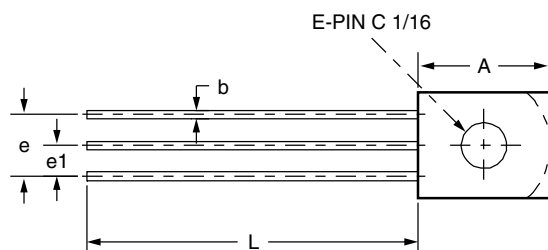
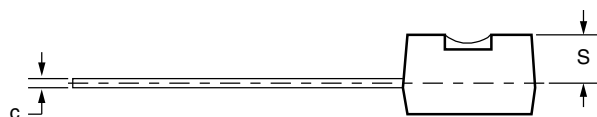

Mechanical Dimensions (continued)

SOT-23 Package

Symbol	Inches		Millimeters		Notes
	Min.	Max.	Min.	Max.	
A	.035	.044	.89	1.12	
A1	.0004	.004	.01	.10	
B	.012	.020	.30	.50	
c	.003	.008	.08	.20	
D	.110	.120	2.80	3.04	
E	.047	.055	1.20	1.40	
e	.037 BSC		.95 BSC		
e1	.075 BSC		1.90 BSC		
H	.083	.104	2.10	2.64	
L	.021 REF		.54 REF		
S	.016 Nom		.395 Nom		

Notes:

1. Dimensions are inclusive of plating.
2. Dimensions are exclusive of mold flash & metal burr.
3. Comply to JEDEC TO-236.
4. This drawing is for matrix leadframe only.

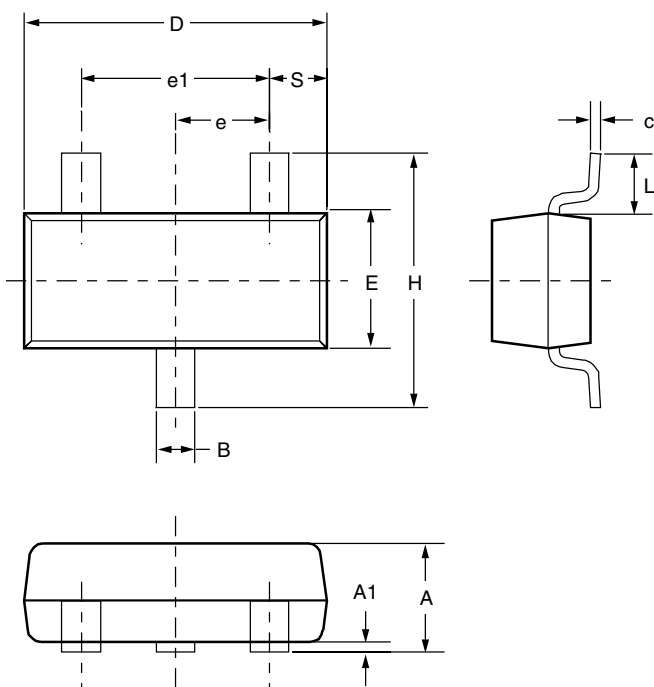

Ordering Information

Example: FAN4041CIS3

<u>FAN4041</u>	<u>C</u>	<u>I</u>	<u>S3</u>	<u>X</u>
<u>Device Family</u>	<u>Grade</u>	<u>Temperature</u>	<u>Package</u>	<u>Tape and Reel = X</u>
	0.5% = C 1.0% = D	-40°C to 85°C = I -40°C to 125°C = E	SOT23 = S3 TO92 = TL	

SOT-23 Package Marking Information

Only 3 fields of marking are possible on an SOT-23. This table gives the meaning of these fields.

Example: FAC

<u>FA</u>	<u>C</u>
	<u>Grade</u>
	0.5% = C 1.0% = D

DISCLAIMER

FAIRCHILD SEMICONDUCTOR RESERVES THE RIGHT TO MAKE CHANGES WITHOUT FURTHER NOTICE TO ANY PRODUCTS HEREIN TO IMPROVE RELIABILITY, FUNCTION OR DESIGN. FAIRCHILD DOES NOT ASSUME ANY LIABILITY ARISING OUT OF THE APPLICATION OR USE OF ANY PRODUCT OR CIRCUIT DESCRIBED HEREIN; NEITHER DOES IT CONVEY ANY LICENSE UNDER ITS PATENT RIGHTS, NOR THE RIGHTS OF OTHERS.

LIFE SUPPORT POLICY

FAIRCHILD'S PRODUCTS ARE NOT AUTHORIZED FOR USE AS CRITICAL COMPONENTS IN LIFE SUPPORT DEVICES OR SYSTEMS WITHOUT THE EXPRESS WRITTEN APPROVAL OF THE PRESIDENT OF FAIRCHILD SEMICONDUCTOR CORPORATION. As used herein:

1. Life support devices or systems are devices or systems which, (a) are intended for surgical implant into the body, or (b) support or sustain life, or (c) whose failure to perform when properly used in accordance with instructions for use provided in the labeling, can be reasonably expected to result in significant injury to the user.
2. A critical component is any component of a life support device or system whose failure to perform can be reasonably expected to cause the failure of the life support device or system, or to affect its safety or effectiveness.