

54F/74F2620 • 54F/74F2623

Inverting Octal Bus Transceiver with 25Ω Series Resistors in the Outputs

General Description

These devices are octal bus transceivers designed for asynchronous two-way data flow between the A and B busses. These devices are functionally equivalent to the 'F620 and 'F623. The 25Ω series resistors in the outputs reduce ringing and eliminate the need for external resistors. Both busses are capable of sinking 12 mA, sourcing 15 mA, and have TRI-STATE outputs. Dual enable pins (GAB, $\overline{\text{G}}\text{BA}$) allow data transmission from the A bus to the B bus or from the B bus to the A bus. The 'F2620 is an inverting option of the 'F2623.

Features

- 25Ω series resistors in the outputs eliminate the need for external resistors.
- Designed for asynchronous two-way data flow between busses
- Outputs sink 12 mA and source 15 mA
- Dual enable inputs control direction of data flow
- Guaranteed 4000V minimum ESD protection
- 'F2620 is an inverting option of the 'F2623

Logic Symbol

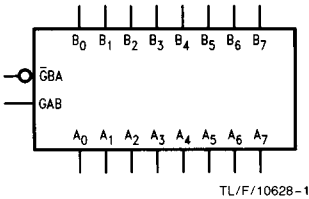

Unit Loading/Fan Out

Pin Names	Description	54F/74F	
		U.L. HIGH/LOW	Input I_{IH}/I_{IL} Output I_{OH}/I_{OL}
$\overline{\text{G}}\text{BA}$, GAB	Enable Inputs	1.0/1.0	20 μA / -0.6 mA
A ₀ -A ₇	A Inputs or TRI-STATE Outputs	3.5/0.667	70 μA / -0.4 mA - 15 mA / 12 mA
B ₀ -B ₇	B Inputs or TRI-STATE Outputs	3.5/0.667	70 μA / -0.4 mA - 15 mA / 12 mA

Connection Diagrams

Pin Assignment for DIP, SOIC and Flatpak

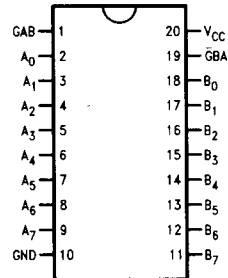

TL/F/10628-2

Pin Assignment for LCC

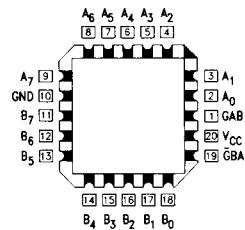

TL/F/10628-3

54F/74F2620 • 54F/74F2623 Inverting Octal Bus Transceiver with 25Ω Series Resistors in the Outputs

Functional Description

The enable inputs GAB and $\overline{G}BA$ control whether data is transmitted from the A bus to the B bus or from the B bus to the A bus to the A bus. If both $\overline{G}BA$ and GAB are disabled ($\overline{G}BA$ HIGH and GAB low), the outputs are in the high impedance state and data is stored at the A and B busses. When $\overline{G}BA$ is active (LOW), B data is sent to the A bus. When GAB is active (HIGH), data from the A bus is sent to the B bus. If both enable inputs are active ($\overline{G}BA$ LOW and GAB HIGH) B data is sent to the A bus while A data is sent to the B bus.

Function Table

Enable Inputs		Operation	
$\overline{G}BA$	GAB	'F2620	'F2623
L	L	\overline{B} Data to A Bus	B Data to A Bus
H	H	\overline{A} Data to B Bus	A Data to B Bus
H	L	Z	Z
L	H	\overline{B} Data to A Bus, \overline{A} Data to B Bus	B Data to A Bus, A Data to B Bus

H = HIGH Voltage Level
L = LOW Voltage Level
Z = High Impedance

Logic Diagram

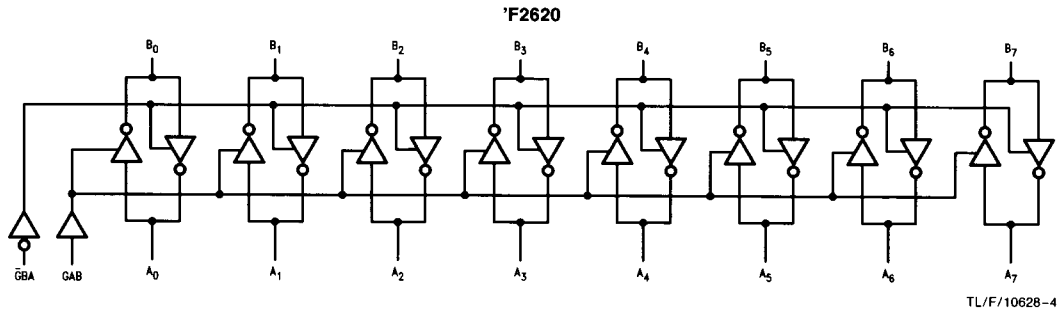

Please note that this diagram is provided only for the understanding of logic operations and should not be used to estimate propagation delays.

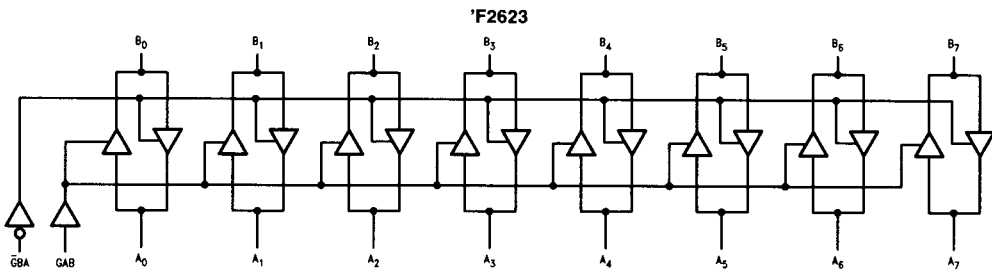

Please note that this diagram is provided only for the understanding of logic operations and should not be used to estimate propagation delays.

Absolute Maximum Ratings (Note 1)

If Military/Aerospace specified devices are required, please contact the National Semiconductor Sales Office/Distributors for availability and specifications.

Storage Temperature	-65°C to +150°C
Ambient Temperature under Bias	-55°C to +125°C
Junction Temperature under Bias	-55°C to +175°C
V _{CC} Pin Potential to Ground Pin	-0.5V to +7.0V
Input Voltage (Note 2)	-0.5V to +7.0V
Input Current (Note 2)	-30 mA to +5.0 mA

Note 1: Absolute maximum ratings are values beyond which the device may be damaged or have its useful life impaired. Functional operation under these conditions is not implied.

Note 2: Either voltage limit or current limit is sufficient to protect inputs.

Voltage Applied to Output in HIGH State (with V _{CC} = 0V)	-0.5V to V _{CC}
Standard Output	-0.5V to +5.5V
TRI-STATE Output	-0.5V to +5.5V
Current Applied to Output in LOW State (Max)	twice the rated I _{OL} (mA)
ESD Last Passing Voltage (Min)	4000V

Recommended Operating Conditions

Free Air Ambient Temperature	-55°C to +125°C
Military	0°C to +70°C
Commercial	
Supply Voltage	
Military	+4.5V to +5.5V
Commercial	+4.5V to +5.5V

DC Electrical Characteristics

Symbol	Parameter	54F/74F			Units	V _{CC}	Conditions
		Min	Typ	Max			
V _{IH}	Input HIGH Voltage	2.0			V		Recognized as a HIGH Signal
V _{IL}	Input LOW Voltage						Recognized as a LOW Signal
V _{CD}	Input Clamp Diode Voltage				-1.2	V	I _{IN} = -18 mA (Non I/O Pins)
V _{OH}	Output HIGH Voltage	54F 10% V _{CC} 74F 10% V _{CC}	2.0 2.0			V	Min I _{OH} = -12 mA (A _n , B _n) I _{OH} = -15 mA (A _n , B _n)
V _{OL}	Output LOW Voltage			0.5 0.75	V	Min	I _{OL} = 1.0 mA (A _n , B _n) I _{OL} = 12 mA (A _n , B _n)
I _{IH}	Input HIGH Current	54F 74F	20.0 5.0		μA	Max	V _{IN} = 2.7V (Non I/O Pins)
I _{BVI}	Input HIGH Current Breakdown Test	54F 74F	100 7.0		μA	Max	V _{IN} = 7.0V (Non I/O Pins)
I _{BVIT}	Input HIGH Current Breakdown Test (I/O)	54F 74F	1.0 0.5		mA	Max	V _{IN} = 5.5V (A _n , B _n)
I _{CEX}	Output HIGH Leakage Current	54F 74F	250 50		μA	Max	V _{OUT} = V _{CC}
V _{ID}	Input Leakage Test	74F	4.75		V	0.0	I _{ID} = 1.9 μA All Other Pins Grounded
I _{OD}	Output Leakage Circuit Current	74F	3.75		μA	0.0	V _{IOD} = 150 mV All Other Pins Grounded
I _{IL}	Input LOW Current				-0.6	mA	Max V _{IN} = 0.5V (Non I/O Pins)
I _{IH} + I _{OZH}	Output Leakage Current				70	μA	Max V _{OUT} = 2.7V (A _n , B _n)
I _{IL} + I _{OZL}	Output Leakage Current				-650	μA	Max V _{OUT} = 0.5V (A _n , B _n)
I _{OS}	Output Short-Circuit Current	-100		-225	mA	Max	V _{OUT} = 0V
I _{ZZ}	Bus Drainage Test				500	μA	0.0V V _{OUT} = 5.25V
I _{CCH}	Power Supply Current ('F2620)				82	mA	Max V _O = HIGH, V _{IN} = 0.2V
I _{CCL}	Power Supply Current ('F2620)				82	mA	Max V _O = LOW
I _{CCZ}	Power Supply Current ('F2620)				95	mA	Max V _O = HIGH Z
I _{CCH}	Power Supply Current ('F2623)				82	mA	Max V _O = HIGH
I _{CCL}	Power Supply Current ('F2623)				82	mA	Max V _O = LOW, V _{IN} = 0.2V
I _{CCZ}	Power Supply Current ('F2623)				95	mA	Max V _O = HIGH Z

AC Electrical Characteristics

Symbol	Parameter	74F			54F		74F		Units
		$T_A = +25^\circ\text{C}$ $V_{CC} = +5.0\text{V}$ $C_L = 50\text{ pF}$			$T_A, V_{CC} = \text{Mil}$ $C_L = 50\text{ pF}$		$T_A, V_{CC} = \text{Com}$ $C_L = 50\text{ pF}$		
		Min	Typ	Max	Min	Max	Min	Max	
t_{PLH} t_{PHL}	Propagation Delay A Input to B Output ('F2620)	2.5 3.0		7.5 8.0			2.0 3.0	8.0 8.0	ns
t_{PLH} t_{PHL}	Propagation Delay B Input to A Output ('F2620)	2.5 3.0		7.5 8.0			2.0 3.0	8.0 8.0	
t_{PLH} t_{PHL}	Propagation Delay A Input to B Output ('F2623)	1.5 2.5		6.5 7.5			1.5 2.5	7.5 8.0	ns
t_{PLH} t_{PHL}	Propagation Delay B Input to A Output ('F2623)	1.5 2.5		6.5 7.5			1.5 2.5	7.5 8.0	
t_{PZH} t_{PZL}	Enable Time G \bar{B} A Input to A Output	2.0 2.5		7.0 8.0			2.0 2.0	8.0 8.5	ns
t_{PHZ} t_{PLZ}	Disable Time G \bar{B} A Input to A Output	1.5 1.0		6.5 5.5			1.5 1.0	7.5 5.5	
t_{PZH} t_{PZL}	Enable Time GAB Input to B Output ('F2620)	2.0 3.0		7.5 8.0			2.0 2.0	8.5 8.5	ns
t_{PHZ} t_{PLZ}	Disable Time GAB Input to B Output ('F2620)	2.5 2.0		8.0 7.5			2.0 2.0	9.0 8.0	
t_{PZH} t_{PZL}	Enable Time GAB Input to B Output ('F2623)	2.0 2.5		7.5 8.0			2.0 2.0	8.5 8.5	ns
t_{PHZ} t_{PLZ}	Disable Time GAB Input to B Output ('F2623)	2.0 2.0		8.0 8.0			2.0 2.0	9.0 8.0	

Basic FAST Circuit Showing Series Resistor Placement

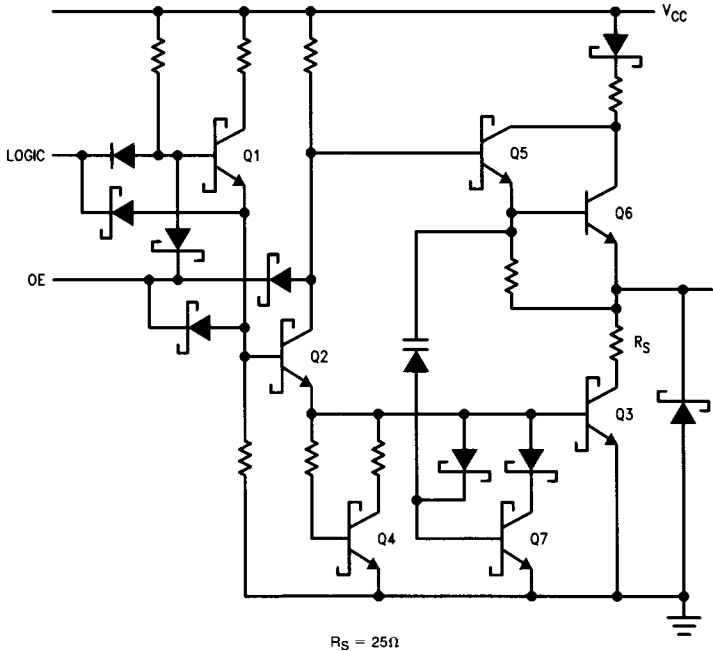

TL/F/10628-6

Ordering Information

The device number is used to form part of a simplified purchasing code where a package type and temperature range are defined as follows:

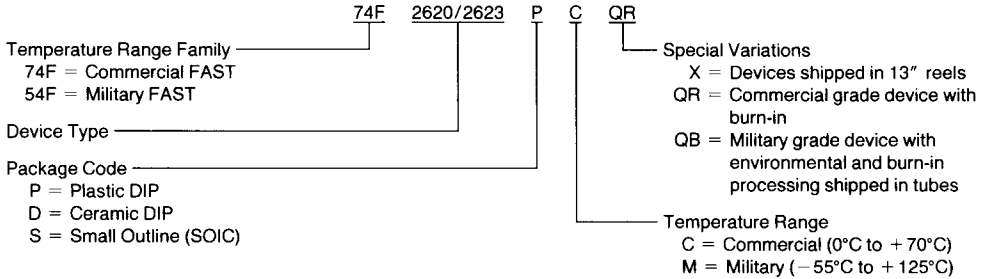

Physical Dimensions inches (millimeters)

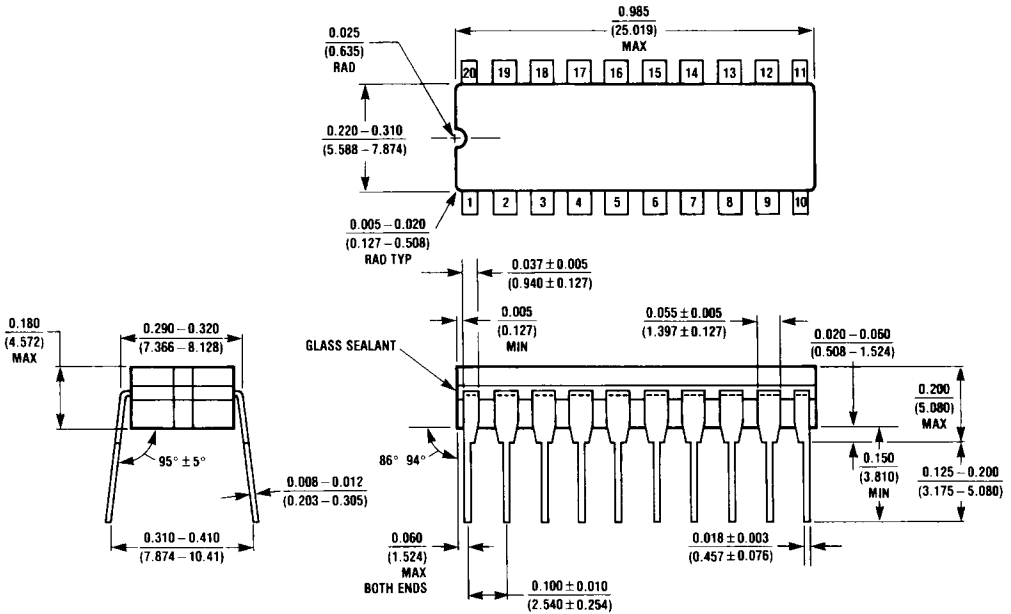

20-Lead Ceramic Dual-In-Line Package (D)
NS Package Number J20A

J20A (REV M)

Physical Dimensions inches (millimeters) (Continued)

Lit. # 114658

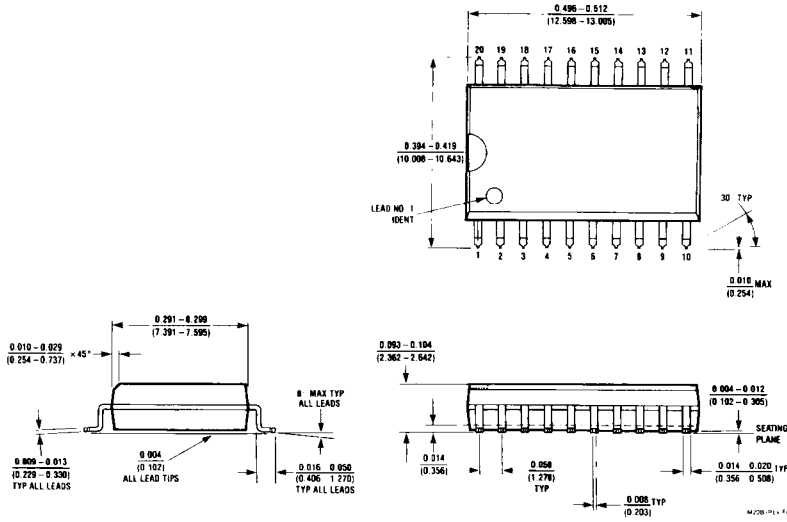

**20-Lead Small Outline Integrated Circuit (S)
NS Package Number M20B**

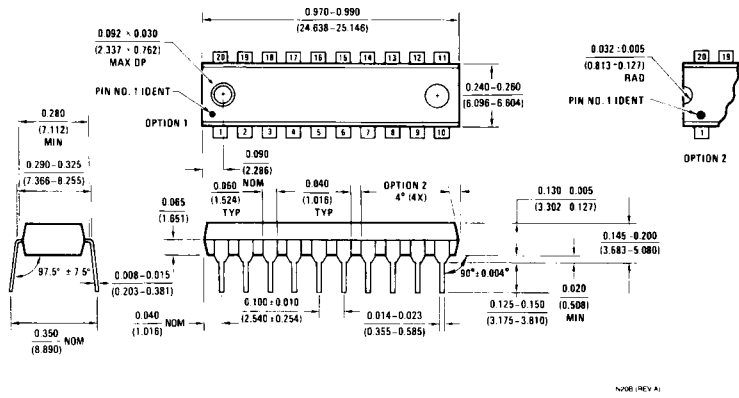

**20-Lead Plastic Dual-In-Line Package (P)
NS Package Number N20B**

LIFE SUPPORT POLICY

NATIONAL'S PRODUCTS ARE NOT AUTHORIZED FOR USE AS CRITICAL COMPONENTS IN LIFE SUPPORT DEVICES OR SYSTEMS WITHOUT THE EXPRESS WRITTEN APPROVAL OF THE PRESIDENT OF NATIONAL SEMICONDUCTOR CORPORATION. As used herein:

1. Life support devices or systems are devices or systems which, (a) are intended for surgical implant into the body, or (b) support or sustain life, and whose failure to perform, when properly used in accordance with instructions for use provided in the labeling, can be reasonably expected to result in a significant injury to the user.
2. A critical component is any component of a life support device or system whose failure to perform can be reasonably expected to cause the failure of the life support device or system, or to affect its safety or effectiveness.

022670 ✓



National Semiconductor Corporation
2900 Semiconductor Drive
P. O. Box 58090
Santa Clara, CA 95052-8090
Tel: 1(800) 272-9959
TWX: (910) 339-9240

National Semiconductor GmbH
Industriestrasse 10
D-8080 Furstenfeldbruck
West Germany
Tel: (0-81-41) 103-0
Telex: 527-649
Fax: (08141) 103554

National Semiconductor Japan Ltd.
Sansoed Bldg. 5F
4-15 Nishi Shinjuku
Shinjuku-Ku,
Tokyo 160, Japan
Tel: 3-299-7001
FAX: 3-299-7000

National Semiconductor Hong Kong Ltd.
Suite 513, 5th Floor
Chinachem Golden Plaza,
77 Mody Road, Tsimshatsui East,
Kowloon, Hong Kong
Tel: 3-7231290
Telex: 52996 NSSEA HX
Fax: 3-3112536

National Semicondutores Do Brasil Ltda.
Av. Brig. Fana Lima, 1383
6-0 Andor-Cont. 62
01451 Sao Paulo, SP, Brasil
Tel: (55/11) 212-5066
Fax: (55/11) 211-1181 NSBR BR

National Semiconductor (Australia) PTY, Ltd.
1st Floor, 441 St. Kilda Rd.
Melbourne, 3004
Victoria, Australia
Tel: (03) 267-5000
Fax: 61-3-267-7458