

NEW BAW101

DUAL, ISOLATED HIGH VOLTAGE SWITCHING DIODES

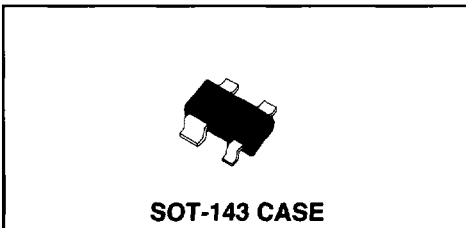

CentralTM Semiconductor Corp.

DESCRIPTION

The CENTRAL SEMICONDUCTOR BAW101 type is a Silicon Dual Isolated High Voltage Switching diode designed for surface mount switching applications requiring high voltage capabilities.

Marking Code is CJP.

MAXIMUM RATINGS (T_A=25°C)

	SYMBOL		UNITS
Continuous Reverse Voltage	V _R	300	V
Peak Repetitive Reverse Voltage	V _{RRM}	300	V
Continuous Forward Current	I _F	200	mA
Peak Repetitive Forward Current	I _{FRM}	500	mA
Forward Surge Current, t _p =1 μs	I _{FSM}	4500	mA
Power Dissipation	P _D	350	mW
Operating and Storage			
Junction Temperature	T _J , T _{stg}	-65 to +150	°C
Thermal Resistance	θ _{JA}	357	°C/W

ELECTRICAL CHARACTERISTICS PER DIODE (T_A=25°C unless otherwise noted)

SYMBOL	TEST CONDITIONS	MIN	TYP	MAX	UNITS
I _R	V _R =250V			150	nA
I _R	V _R =250V, T _A =150°C			50	μA
B _V R	I _R =100μA	300			V
V _F	I _F =100mA		0.9	1.3	V
C _T	V _R =0V, f=1.0MHz			5.0	pF
t _{rr}	I _F =I _R =30mA, I _{rr} =3.0mA, R _L =100Ω			50	ns

All Dimensions in Inches (mm).

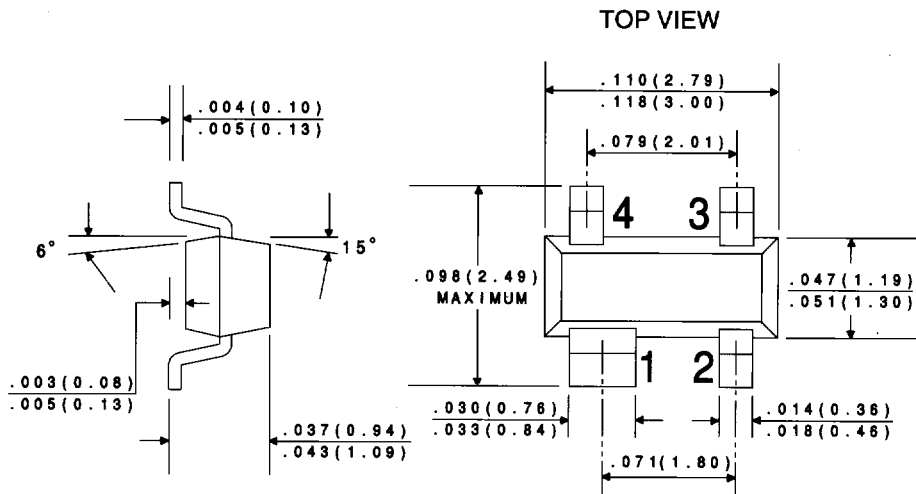

LEAD CODE:

- 1) Cathode 1
- 2) Cathode 2
- 3) Anode 2
- 4) Anode 1

DATA SHEET