

SN54ALS996, SN74ALS996 8-BIT D-TYPE EDGE-TRIGGERED READ-BACK LATCHES

SDAS0088B - OCTOBER 1984 - REVISED JANUARY 1995

- 3-State I/O-Type Read-Back Inputs
- Bus-Structured Pinout
- T/\bar{C} Determines True or Complementary Data at Q Outputs
- Package Options Include Plastic Small-Outline (DW) Packages, Ceramic Chip Carriers (FK), and Standard Plastic (NT) and Ceramic (JT) 300-mil DIPs

description

These 8-bit latches are designed specifically for storing the contents of the input data bus and providing the capability of reading back the stored data onto the input data bus. The Q outputs are designed with bus-driving capability.

The edge-triggered flip-flops enter the data on the low-to-high transition of the clock (CLK) input when the enable (EN) input is low. Data can be read back onto the data inputs by taking the read ($\bar{R}D$) input low, in addition to having $\bar{E}N$ low. When $\bar{E}N$ is high, both the read-back and write modes are disabled. Transitions on $\bar{E}N$ should only be made with CLK high to prevent false clocking.

The polarity of the Q outputs can be controlled by the polarity (T/\bar{C}) input. When T/\bar{C} is high, Q is the same as is stored in the flip-flops. When T/\bar{C} is low, the output data is inverted. The Q outputs can be placed in the high-impedance state by taking the output-enable ($\bar{O}E$) input high. $\bar{O}E$ does not affect the internal operation of the register. Old data can be retained or new data can be entered while the outputs are off.

A low level at the clear ($\bar{C}LR$) input resets the internal registers low. The clear function is asynchronous and overrides all other register functions.

The -1 version of the SN74ALS996 is identical to the standard version, except that the recommended maximum I_{OL} for the -1 version is increased to 48 mA. There is no -1 version of the SN54ALS996.

The SN54ALS996 is characterized for operation over the full military temperature range of -55°C to 125°C . The SN74ALS996 is characterized for operation from 0°C to 70°C .

SN54ALS996 ... JT PACKAGE
SN74ALS996 ... DW OR NT PACKAGE
(TOP VIEW)

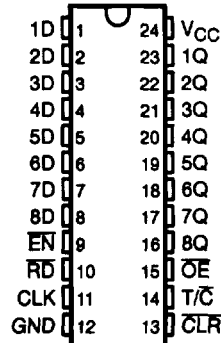

SN54ALS996 ... FK PACKAGE
(TOP VIEW)

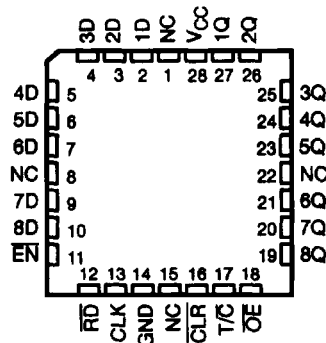

NC - No Internal connection

PRODUCTION DATA information is current as of publication date. Products conform to specifications per the terms of Texas Instruments standard warranty. Production processing does not necessarily include testing of all parameters.



POST OFFICE BOX 655303 • DALLAS, TEXAS 75265

Copyright © 1995, Texas Instruments Incorporated

SN54ALS996, SN74ALS996

8-BIT D-TYPE EDGE-TRIGGERED READ-BACK LATCHES

SDAS098B - OCTOBER 1984 - REVISED JANUARY 1995

logic symbol†

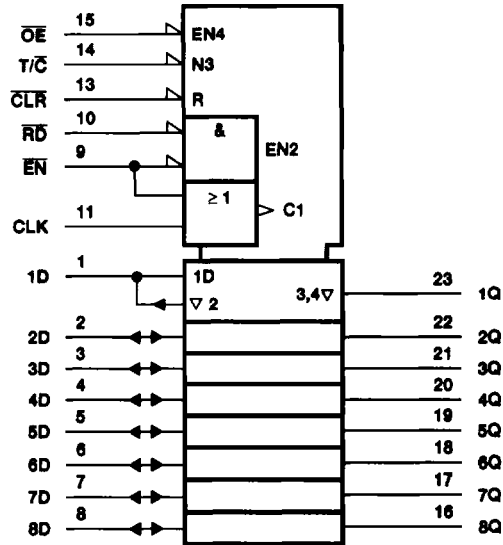

† This symbol is in accordance with ANSI/IEEE Std 91-1984 and IEC Publication 617-12. Pin numbers shown are for the DW, JT, and NT packages.

logic diagram (positive logic)

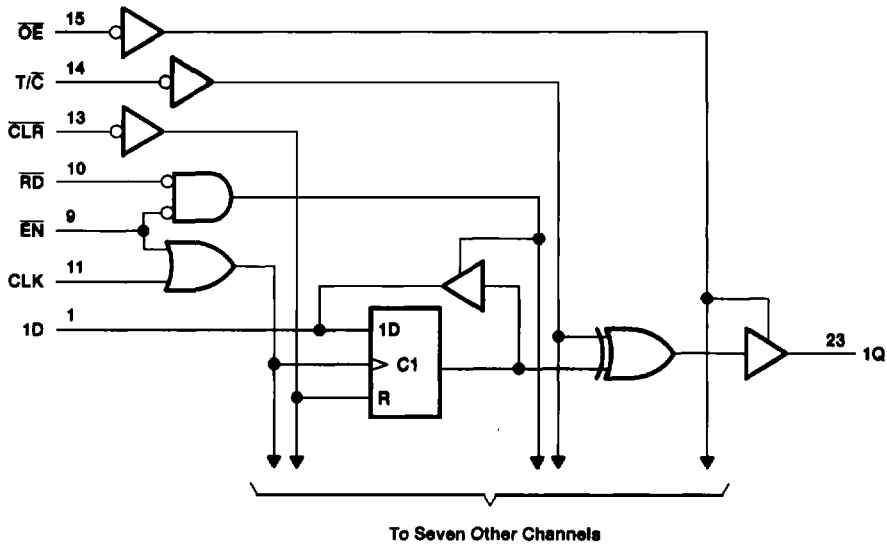

Pin numbers shown are for the DW, JT, and NT packages.

SN54ALS996, SN74ALS996 8-BIT D-TYPE EDGE-TRIGGERED READ-BACK LATCHES

SDAS098B - OCTOBER 1984 - REVISED JANUARY 1995

timing diagram

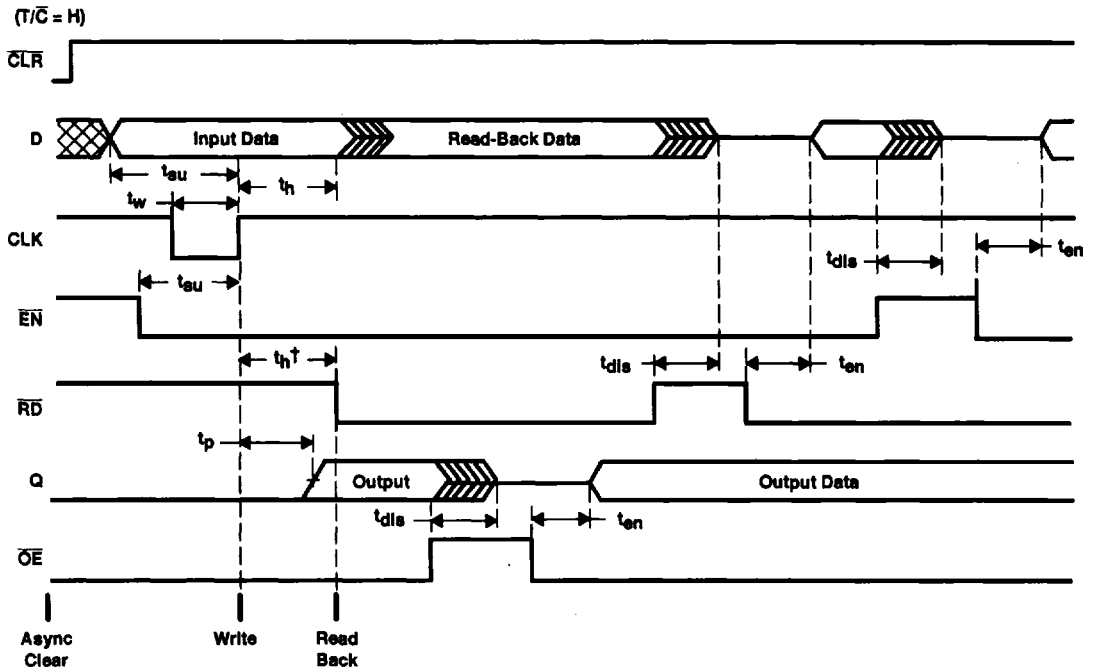

† This hold time ensures that the read-back circuit will not create a conflict on the input data bus.

absolute maximum ratings over operating free-air temperature range (unless otherwise noted)‡

Supply voltage, V_{CC}	7 V
Input voltage, V_I (\bar{OE} , \bar{RD} , \bar{EN} , CLK, \bar{CLR} , and T/\bar{C})	7 V
Voltage applied to D inputs and to disabled 3-state outputs	5.5 V
Operating free-air temperature range, T_A : SN54ALS996	-55°C to 125°C
SN74ALS996	0°C to 70°C
Storage temperature range	-65°C to 150°C

‡ Stresses beyond those listed under "absolute maximum ratings" may cause permanent damage to the device. These are stress ratings only, and functional operation of the device at these or any other conditions beyond those indicated under "recommended operating conditions" is not implied. Exposure to absolute-maximum-rated conditions for extended periods may affect device reliability.



POST OFFICE BOX 855303 • DALLAS, TEXAS 75286

2-723

SN54ALS996, SN74ALS996 8-BIT D-TYPE EDGE-TRIGGERED READ-BACK LATCHES

SDAS098B - OCTOBER 1984 - REVISED JANUARY 1995

recommended operating conditions

		SN54ALS996			SN74ALS996			UNIT		
		MIN	NOM	MAX	MIN	NOM	MAX			
V _{CC}	Supply voltage	4.5	5	5.5	4.5	5	5.5	V		
V _{IH}	High-level input voltage	All inputs			2			V		
		All inputs except \overline{OE} , \overline{RD}			2					
		\overline{OE} , \overline{RD}			2.2					
V _{IL}	Low-level input voltage			0.8			0.8	V		
I _{OH}	High-level output current	Q			-1			mA		
		D			-0.4					
I _{OL}	Low-level output current	Q			12			mA		
					24					
		D			48†					
f _{clock}	Clock frequency	0			35			MHZ		
					8					
t _w	Pulse duration	\overline{CLR} low			10			ns		
		CLK low			14.5					
		CLK high			14.5					
t _{su}	Setup time	Data before CLK↑			15			ns		
		\overline{EN} low before CLK↑			10					
		CLK high before \overline{EN} ↑‡			15					
		\overline{CLR} high (inactive) before CLK↑			10					
t _h	Hold time	Data after CLK↑			1			ns		
		\overline{EN} low after CLK↑			5					
		\overline{RD} high after CLK↑§			5					
T _A	Operating free-air temperature	-55			125			0	70	°C

† Applies only to the -1 version and only if V_{CC} is maintained between 4.75 V and 5.25 V

‡ This setup time ensures that \overline{EN} will not false clock the data register.

§ This hold time ensures that there will be no conflict on the input data bus.

SN54ALS996, SN74ALS996 8-BIT D-TYPE EDGE-TRIGGERED READ-BACK LATCHES

SDAS098B - OCTOBER 1984 - REVISED JANUARY 1995

electrical characteristics over recommended operating free-air temperature range (unless otherwise noted)

PARAMETER	TEST CONDITIONS	SN54ALS996		SN74ALS996		UNIT	
		MIN	TYP†	MAX	MIN		TYP†
V_{IK}	$V_{CC} = 4.5 \text{ V}$, $I_I = -18 \text{ mA}$			-1.2		-1.2	V
V_{OH}	All outputs $V_{CC} = 4.5 \text{ V to } 5.5 \text{ V}$, $I_{OH} = -0.4 \text{ mA}$	$V_{CC} - 2$		$V_{CC} - 2$		V	
	Q $V_{CC} = 4.5 \text{ V}$	2.4	3.2	2.4	3.2		
V_{OL}	D $V_{CC} = 4.5 \text{ V}$	$I_{OL} = 4 \text{ mA}$	0.25	0.4		V	
		$I_{OL} = 8 \text{ mA}$			0.35		0.5
	Q $V_{CC} = 4.5 \text{ V}$	$I_{OL} = 12 \text{ mA}$	0.25	0.4	0.25		0.4
		$I_{OL} = 24 \text{ mA}$			0.35		0.5
		$I_{OL} = 48 \text{ mA}^\ddagger$			0.35	0.5	
I_{OZH}	Q $V_{CC} = 5.5 \text{ V}$, $V_O = 2.7 \text{ V}$			20		20	μA
I_{OZL}	Q $V_{CC} = 5.5 \text{ V}$, $V_O = 0.4 \text{ V}$			-20		-20	μA
I_I	D inputs $V_{CC} = 5.5 \text{ V}$			0.1		0.1	mA
	All others $V_I = 7 \text{ V}$			0.1		0.1	
I_{IH}	D inputs § $V_{CC} = 5.5 \text{ V}$, $V_I = 2.7 \text{ V}$			20		20	μA
	All others			20		20	
I_{IL}	D inputs § $V_{CC} = 5.5 \text{ V}$, $V_I = 0.4 \text{ V}$			-0.1		-0.1	mA
	All others			-0.1		-0.1	
I_O^\ddagger	$V_{CC} = 5.5 \text{ V}$, $CLR = 2.5 \text{ V}$, $V_O = 2.25 \text{ V}$	-20		-112	-30	-112	mA
I_{CC}	$V_{CC} = 5.5 \text{ V}$, $EN, RD \text{ low}$	Outputs high	35	55	35	55	mA
		Outputs low	55	85	55	85	
		Outputs disabled	42	65	42	65	

† All typical values are at $V_{CC} = 5 \text{ V}$, $T_A = 25^\circ\text{C}$.

‡ Applies only to the -1 version and only if V_{CC} is maintained between 4.75 V and 5.25 V

§ For I/O ports (Q_A thru Q_H), the parameters I_{IH} and I_{IL} include the off-state output current.

¶ The output conditions have been chosen to produce a current that closely approximates one half of the true short-circuit output current, I_{OS} .



POST OFFICE BOX 655303 • DALLAS, TEXAS 75265

2-725

SN54ALS996, SN74ALS996

8-BIT D-TYPE EDGE-TRIGGERED READ-BACK LATCHES

SDAS008B - OCTOBER 1984 - REVISED JANUARY 1995

switching characteristics (see Figure 1)

PARAMETER	FROM (INPUT)	TO (OUTPUT)	V _{CC} = 4.5 V to 5.5 V, C _L = 50 pF, T _A = MIN to MAX†				UNIT
			SN54ALS996		SN74ALS996		
			MIN	MAX	MIN	MAX	
t _{max}			35		35		MHz
t _{PLH}	CLK (T/C = H or L)	Q	5	30	5	28	ns
t _{PHL}			5	24	5	28	
t _{PLH}	$\overline{\text{CLR}}$ (T/C = L)	Q	5	27	7	27	ns
t _{PHL}	$\overline{\text{CLR}}$ (T/C = H)		5	23	7	23	
t _{PLH}	T/C	Q	4	23	5	23	ns
t _{PHL}			5	23	5	23	
t _{PHL}	$\overline{\text{CLR}}$	D	5	30	8	30	ns
t _{en} ‡	RD	D	2	18	3	16	ns
t _{dis} §			1	19	3	19	
t _{en} ‡	EN	D	2	17	3	16	ns
t _{dis} §			1	19	3	19	
t _{en} ‡	$\overline{\text{OE}}$	Q	2	15	4	15	ns
t _{dis} §			1	11	1	10	

† For conditions shown as MIN or MAX, use the appropriate value specified under recommended operating conditions.

‡ t_{en} = t_{PZH} or t_{PZL}

§ t_{dis} = t_{PHZ} or t_{PLZ}



POST OFFICE BOX 655303 • DALLAS, TEXAS 75265

SN54ALS996, SN74ALS996 8-BIT D-TYPE EDGE-TRIGGERED READ-BACK LATCHES

SDAS098B - OCTOBER 1984 - REVISED JANUARY 1995

PARAMETER MEASUREMENT INFORMATION

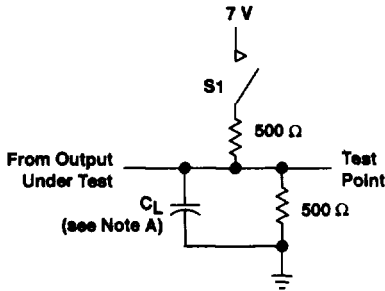

LOAD CIRCUIT FOR Q OUTPUTS

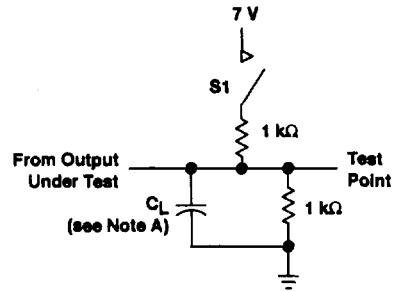

LOAD CIRCUIT FOR D OUTPUTS

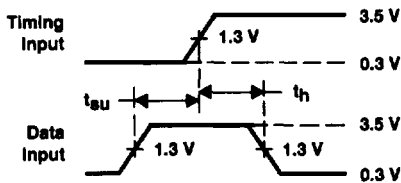

VOLTAGE WAVEFORMS
SETUP AND HOLD TIMES

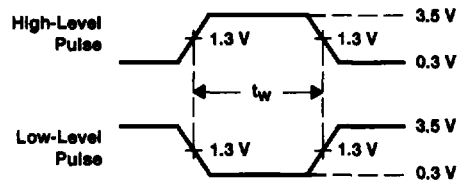

VOLTAGE WAVEFORMS
PULSE DURATIONS

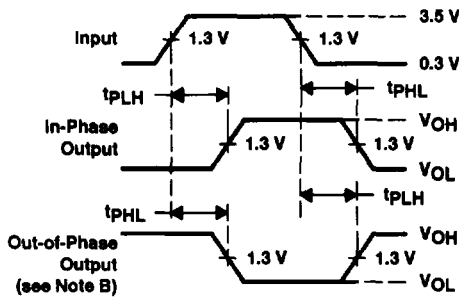

VOLTAGE WAVEFORMS
PROPAGATION DELAY TIMES

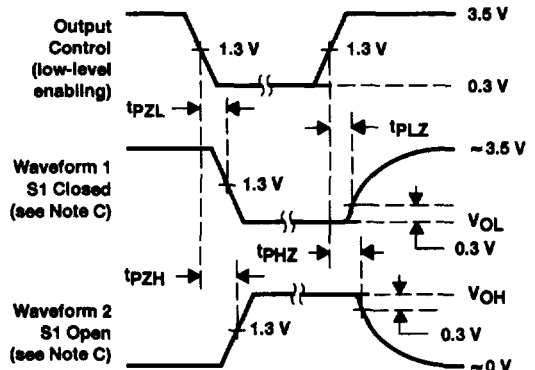

VOLTAGE WAVEFORMS
ENABLE AND DISABLE TIMES, 3-STATE OUTPUTS

- NOTES: A. C_L includes probe and jig capacitance.
 B. When measuring propagation delay times of 3-state outputs, switch S1 is open.
 C. Waveform 1 is for an output with internal conditions such that the output is low except when disabled by the output control. Waveform 2 is for an output with internal conditions such that the output is high except when disabled by the output control.
 D. All input pulses have the following characteristics: $PRR \leq 1$ MHz, $t_r = t_f = 2$ ns, duty cycle = 50%.

Figure 1. Load Circuits and Voltage Waveforms



POST OFFICE BOX 856303 • DALLAS, TEXAS 75285