



7-52-33-15

UPI-452 CHMOS PROGRAMMABLE I/O PROCESSOR

83C452 - 8K × 8 Mask Programmable Internal ROM

80C452 - External ROM/EPROM

- 83C452/80C452:3.5 to 14 MHz Clock Rate
- Software Compatible with the MCS-51 Family
- 128-Byte Bi-Directional FIFO Slave Interface
- Two DMA Channels
- 256 × 8-Bit Internal RAM
- 34 Additional Special Function Registers
- 40 Programmable I/O Lines
- Two 16-Bit Timer/Counters
- Boolean Processor
- Bit Addressable RAM
- 8 Interrupt Sources
- Programmable Full Duplex Serial Channel
- 64K Program Memory Space
- 64K Data Memory Space
- 68-Pin PGA and PLCC

(See Packaging Spec., Order: #231369)

The Intel UPI-452 (Universal Peripheral Interface) is a 68 pin CHMOS Slave I/O Processor with a sophisticated bi-directional FIFO buffer interface on the slave bus and a two channel DMA processor on-chip. The UPI-452 is the newest member of Intel's UPI family of products. It is a general-purpose slave I/O Processor that allows the designer to grow a customized interface solution.

The UPI-452 contains a complete 80C51 with twice the on-chip data and program memory. The sophisticated slave FIFO module acts as a buffer between the UPI-452 internal CPU and the external host CPU. To both the external host and the internal CPU, the FIFO module looks like a bi-directional bottomless buffer that can both read and write data. The FIFO manages the transfer of data independent of the UPI-452 core CPU and generates an interrupt or DMA request to either CPU, host or internal, as a FIFO service request.

The FIFO consists of two channels: the Input FIFO and the Output FIFO. The division of the FIFO module array, 128 bytes, between Input channel and Output channel is programmable by the user. Each FIFO byte has an additional logical ninth bit to distinguish between a data byte and a Data Stream Command byte. Additionally, Immediate Commands allow direct, interrupt driven, bi-directional communication between the UPI-452 internal CPU and external host CPU, bypassing the FIFO.

The on-chip DMA processor allows high speed data transfers from one writeable memory space to another. As many as 64K bytes can be transferred in a single DMA operation. Three distinct memory spaces may be used in DMA operations; Internal Data Memory, External Data Memory, and the Special Function Registers (including the FIFO IN, FIFO OUT, and Serial Channel Special Functions Registers).

9000-0728

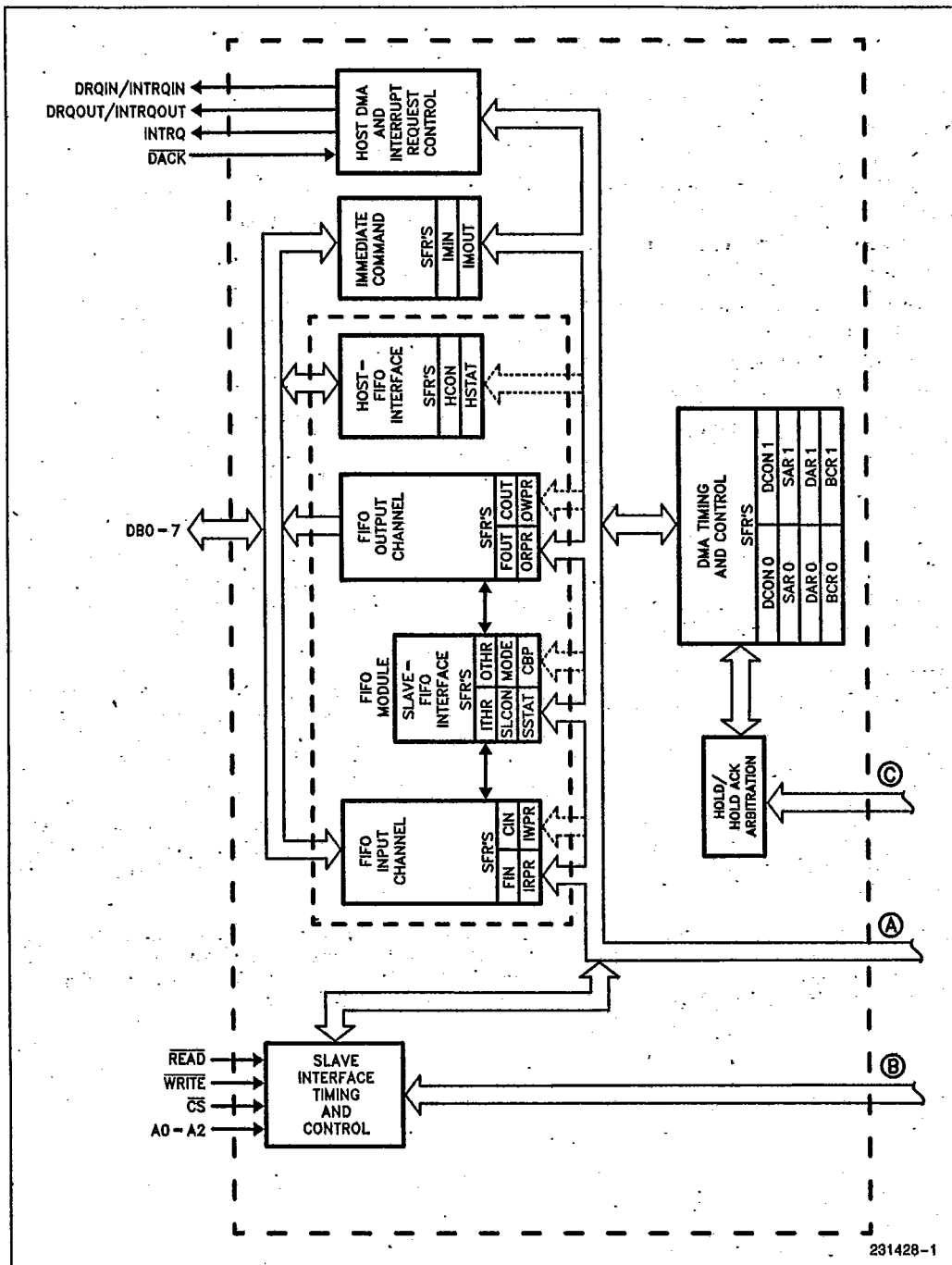

Figure 1. Architectural Block Diagram

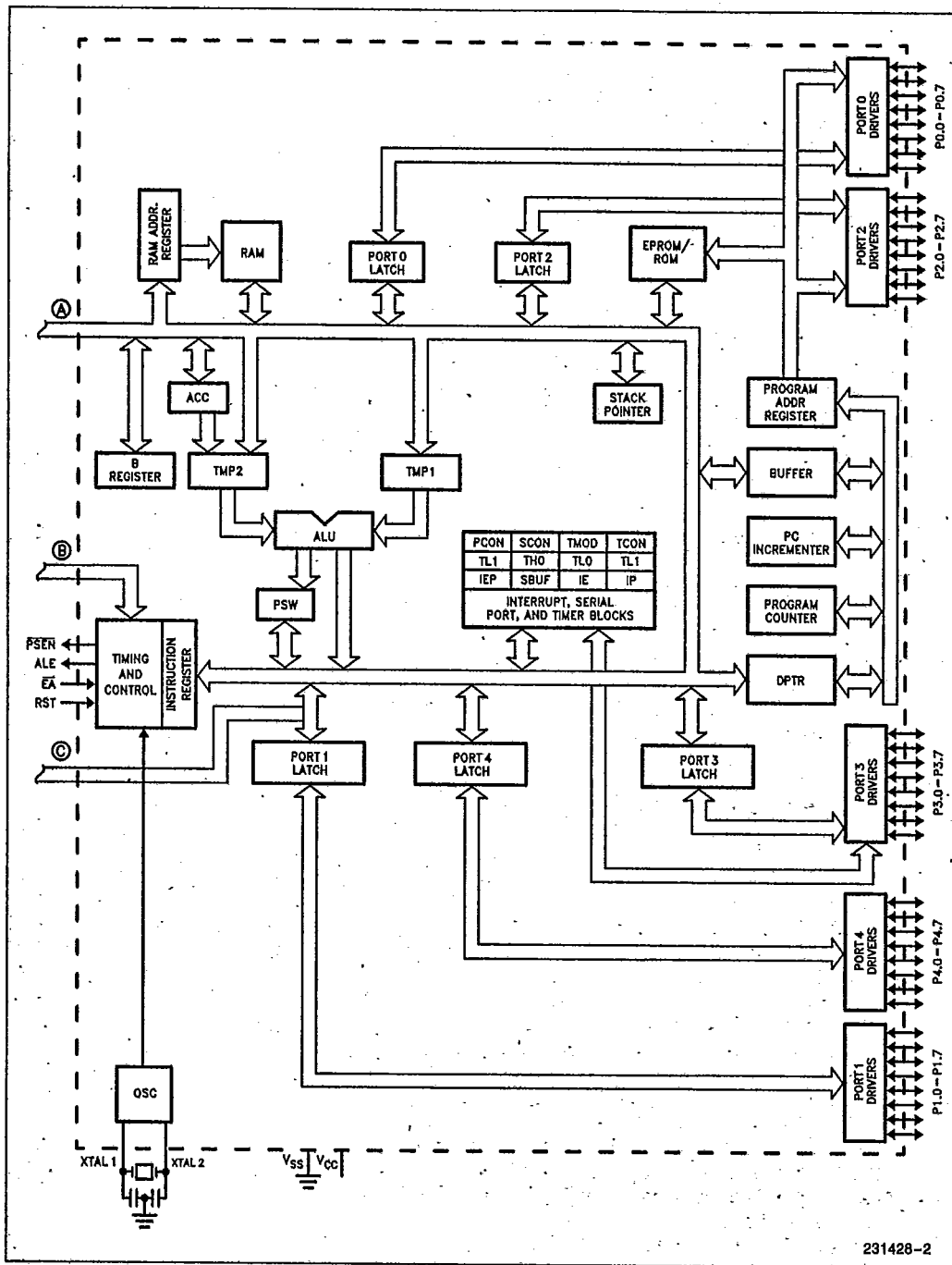

Figure 1. Architectural Block Diagram (Continued)

6

TABLE OF CONTENTS

CONTENTS	PAGE
Introduction	6-69
Table of Contents	6-72
List of Tables and Figures	6-73
Pin Description	6-76
Architectural Overview	6-79
Introduction	6-79
FIFO Buffer Interface	6-79
FIFO Programmable Features	6-80
Immediate Commands	6-81
DMA	6-81
FIFO/Slave Interface Functional Description	6-81
Overview	6-81
Input FIFO Channel	6-81
Output FIFO Channel	6-83
Immediate Commands	6-84
Host & Slave Interface Special Function Registers	6-86
Slave Interface Special Function Registers	6-86
External Host Interface Special Function Registers	6-88
FIFO Module—External Host Interface	6-90
Overview	6-90
Slave Interface Address Decoding	6-90
Interrupts to the Host	6-90
DMA Requests to the Host	6-92
FIFO Module—Internal CPU Interface	6-92
Overview	6-92
Internal CPU Access to FIFO via Software Instructions	6-92
General Purpose DMA Channels	6-93
Overview	6-93
Architecture	6-93
DMA Special Function Registers	6-94
DMA Transfer Modes	6-95
External Memory DMA	6-97
Latency	6-97
DMA Interrupt Vectors	6-97
Interrupts When DMA is Active	6-98
DMA Arbitration	6-98
Interrupts	6-100
Overview	6-100
FIFO Module Interrupts to Internal CPU	6-100
Interrupt Enabling and Priority	6-101
FIFO—External Host Interface FIFO DMA Freeze Mode	6-103
Overview	6-103
Initialization	6-103
Invoking FIFO DMA Freeze Mode During Normal Operation	6-104
FIFO Module Special Function Register Operation During FIFO DMA Freeze Mode	6-105
Internal CPU Read & Write of the FIFO During FIFO DMA Freeze Mode	6-109
Memory Organization	6-109
Accessing External Memory	6-109
Miscellaneous Special Function Register Descriptions	6-111

**LIST OF TABLES AND FIGURES****Figures:**

1. Architectural Block Diagram	6-70
2. UPI-452 68-Pin PGA Pinout Diagram	6-74
3. UPI-452 Conceptual Block Diagram	6-79
4. UPI-452 Functional Block Diagram	6-80
5. Input FIFO Channel Functional Block Diagram	6-82
6. Output FIFO Channel Functional Block Diagram	6-83
7a. Handshake Mechanisms for Handling Immediate Command IN Flowchart	6-85
7b. Handshake Mechanisms for Handling Immediate Command OUT Flowchart	6-85
8. DMA Transfer from: External to External Memory	6-99
9. DMA Transfer from: External to Internal Memory	6-99
10. DMA Transfer from: Internal to External Memory	6-99
11. DMA Transfer Waveform: Internal to Internal Memory	6-100
12. Disabling FIFO to Host Slave Interface Timing Diagram	6-104

Tables:

1. Input FIFO Channel Registers	6-81
2. Output FIFO Channel Registers	6-83
3. UPI-452 Address Decoding	6-91
4. DMA Accessible Special Function Registers	6-94
5. DMA Mode Control - PCON SFR	6-97
6. Interrupt Priority	6-100
7. Interrupt Vector Addresses	6-100
8. Slave Bus Interface Status During FIFO DMA Freeze Mode	6-103
9. FIFO SFR's Characteristics During FIFO DMA Freeze Mode	6-106
10. Threshold SFRs Range of Values and Number of Bytes to be Transferred	6-107
11a. Internal Memory Addressing	6-109
11b. 80C51 Special Function Registers	6-110
11c. UPI-452 Additional Special Function Registers	6-110
12. Program Status Word (PSW)	6-112
13. PCON Special Function Register	6-112

6



UPI MICROCONTROLLER FAMILY

The UPI-452 joins the current members of the UPI microcontroller family. UPI's are derivatives of the MCST[™] family of microcontrollers. Because of their on-chip system bus interface, UPI's are designed to be system bus "slaves", while their microcontroller counterparts are intended as system bus "masters".

These UPI Microcontrollers are fully supported by Intel's development tools (ICE, ASM and PLM).

Packaging

The 80C452/83C452 is available in either a 68-pin PGA (Pin Grid Array) or 68-pin PLCC package.

UPI Family (Slave Configuration)	MCS Family (Master Configuration)	Speed	RAM (Bytes)	ROM (Bytes)
80C452	80C51	12 MHz	256	—
83C452	80C51	12 MHz	256	8K
80C452-1	80C51	14 MHz	256	—
83C452-1	80C51	14 MHz	256	8K

UPI-452 PIN DESCRIPTIONS

Symbol	Pin #	Type	Name and Function
V _{SS}	9/43	I	Circuit Ground.
V _{CC}	60	I	+5V power supply during normal and idle mode operation. It is also the standby power pin for power down mode.
XTAL1	38	I	Input to the oscillator's high gain amplifier. A crystal or external source can be used.
XTAL2	39	O	Output from the high gain amplifier.
Port 0 (AD0-AD7) P0.0 .1 .2 .3 .4 .5 .6 P0.7	8 10 11 12 13 14 15 16	I/O	Port 0 is an 8-bit open drain bi-directional I/O port. Port 0 can sink eight LS TTL inputs. It is also the multiplexed low-order address and data local expansion bus during accesses to external memory.



UPI-452

T-52-33-15

UPI-452 PIN DESCRIPTIONS (Continued)

Symbol	Pin #	Type	Name and Function
Port 4 P4.0 .1 .2 .3 .4 .5 .6 .7	30 32 33 34 35 36 37	I/O	Port 4 is an 8-bit quasi-bi-directional I/O port. Port 4 can sink/source four TTL inputs.
RST	20	I	A high level on this pin for two machine cycles while the oscillator is running resets the device. An internal pulldown resistor permits Power-on reset using only a capacitor connected to V _{CC} . This pin does not receive the power down voltage as is the case for HMOS MCS-51 family members. This function has been transferred to the V _{CC} pin.
ALE	18	O	Provides Address Latch Enable output used for latching the address into external memory during normal operation. ALE can sink/source eight LS TTL inputs.
PSEN	19	O	The Program Store Enable output is a control signal that enables the external Program Memory to the bus during normal fetch operation. PSEN can sink/source eight LS TTL inputs.
EA	17	I	When held at TTL high level, the UPI-452 executes instructions from the internal ROM when the PC is less than 8192 (8K, 2000H). When held at a TTL low level, the UPI-452 fetches all instructions from external Program Memory.
DB0 DB1 DB2 DB3 DB4 DB5 DB6 DB7	58 57 56 55 54 53 52 51	I/O	Host Bus Interface is an 8-bit bi-directional bus. It is used to transfer data and commands between the UPI-452 and the host processor. This bus can sink/source eight LS TTL inputs.
CS	44	I	This pin is the Chip Select of the UPI-452.
A0 A1 A2	40 41 42	I	These three address lines are used to interface with the host system. They define the UPI-452 operations. The interface is compatible with the Intel microprocessors and the MULTIBUS.
READ	46	I	This pin is the read strobe from the host CPU. Activating this pin causes the UPI-452 to place the contents of the Output FIFO (either a command or data) or the Host Status/Control Special Function Register on the Slave Data Bus.
WRITE	47	I	This pin is the write strobe from the host. Activating this pin will cause the value on the Slave Data Bus to be written into the register specified by A0-A2.
DRQIN/ INTRQIN	49	O	This pin requests an input transfer from the host system whenever the Input Channel requires data.
DRQOUT/ INTRQOUT	48	O	This output pin requests an output transfer whenever the Output Channel requires service. If the external host to UPI-452 DMA is enabled, and a Data Stream Command is at the Output FIFO, DRQOUT is deactivated and INTRQ is activated (see 'GENERAL PURPOSE DMA CHANNELS' section).



T-52-33-15

UPI-452 PIN DESCRIPTIONS (Continued)

Symbol	Pin #	Type	Name and Function
INTRQ	50	O	This output pin is used to interrupt the host processor when an Immediate Command Out or an error condition is encountered. It is also used to interrupt the host processor when the FIFO requests service if the DMA is disabled and INTRQIN and INTRQOUT are not used.
DACK	45	I	This pin is the DMA acknowledge for the host bus interface Input and Output Channels. When activated, a write command will cause the data on the Slave Data Bus to be written as data to the Input Channel (to the Input FIFO). A read command will cause the Output Channel to output data (from the Output FIFO) on to the Slave Data Bus. This pin should be driven high (+5V) in systems which do not have a DMA controller (see Address Decoding).
Vcc	26	I	+5V power supply during operation.

ARCHITECTURAL OVERVIEW

Introduction

The UPI-452 slave microcontroller incorporates an 80C51 with double the program and data memory, a slave interface which allows it to be connected directly to the host system bus as a peripheral, a FIFO buffer module, a two channel DMA processor, and a fifth I/O port (Figure 3). The UPI-452 retains all of the 80C51 architecture, and is fully compatible with the MCS-51 instruction set.

The Special Function Register (SFR) interface concept introduced in the MCS-51 family of microcontrollers has been expanded in the UPI-452. To the 20 Special Function Registers of the MCS-51, the UPI-452 adds 34 more. These additional Special Function Registers, like those of the MCS-51, provide access to the UPI-452 functional elements including the FIFO, DMA and added interrupt capabilities. Several of the 80C51 core Special Function Registers have also been expanded to support added features of the UPI-452.

This data sheet describes the unique features of the UPI-452. Refer to the 80C51 data sheet for a de-

scription of the UPI-452's core CPU functional blocks including;

- Timers/Counters
- I/O Ports
- Interrupt timing and control (other than FIFO and DMA interrupts)
- Serial Channel
- Local Expansion Bus
- Program/Data Memory structure
- Power-Saving Modes of Operation
- CMOS Features
- Instruction Set

Figure 3 contains a conceptual block diagram of the UPI-452. Figure 4 provides a functional block diagram.

FIFO Buffer Interface

A unique feature of the UPI-452 is the incorporation of a 128 byte FIFO array at the host-slave interface. The FIFO allows asynchronous bi-directional transfers between the host CPU and the internal CPU.

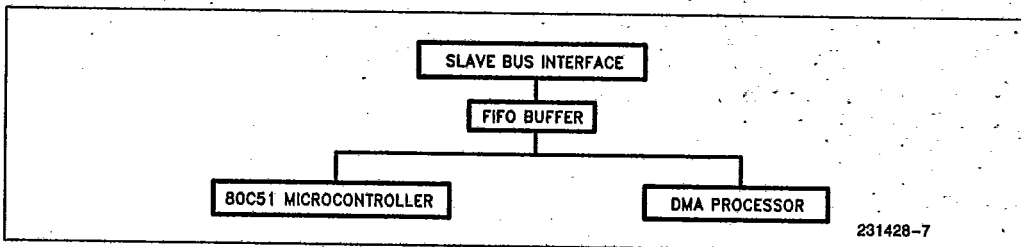

Figure 3. UPI-452 Conceptual Block Diagram



UPI-452

T-52-33-15

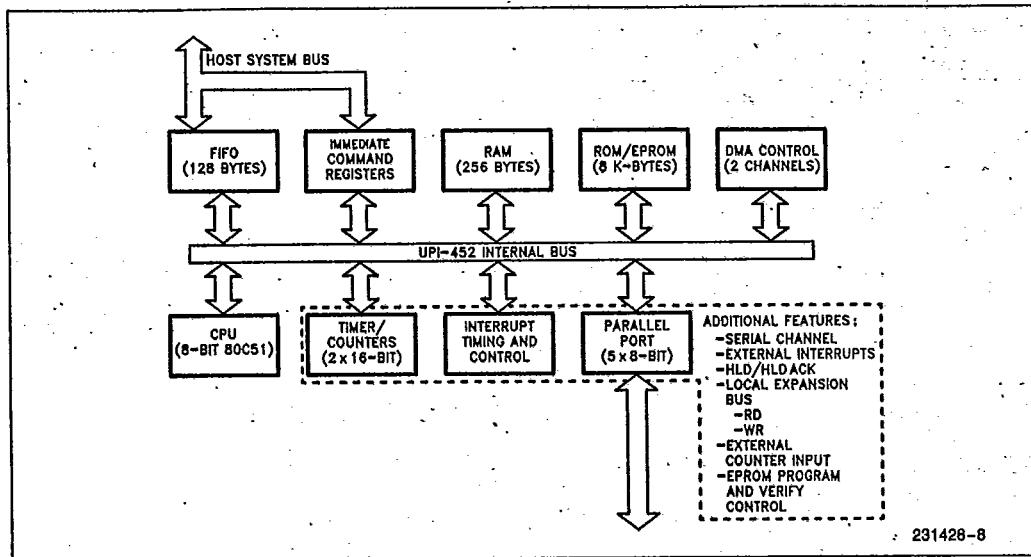

Figure 4. UPI-452 Functional Block Diagram

The division of the 128 bytes between Input and Output channels is user programmable allowing maximum flexibility. If the entire 128 byte FIFO is allocated to the Input channel, a high performance Host can transfer up to 128 bytes at one time, then dedicate its resources to other functions while the internal CPU processes the data in the FIFO. Various handshake signals allow the external Host to operate independently and without frequent monitoring of the UPI-452 internal CPU. The FIFO Buffer insures that the slave processor receives data in the same order that it was sent by the host without the need to keep track of addresses. Three slave bus interface handshake methods are supported by the UPI-452: DMA, Interrupt and Polled.

The FIFO is nine bits wide. The ninth bit acts as a command/data flag. Commands written to the FIFO by either the host or internal CPU are called Data Stream Commands or DSCs. DSCs are written to the input FIFO by the Host via a unique external address. DSCs are written to the output FIFO by the internal CPU via the COMMAND OUT Special Function Register (SFR). When encountered by the host or Internal CPU a Data Stream Command can be used as an address vector to user defined service routines. DSCs provide synchronization of data and commands between the Host and internal CPU.

FIFO PROGRAMMABLE FEATURES

Size of Input/Output Channels

The 128 bytes of FIFO space can be allocated between the Input and Output channels via the Chan-

nel Boundary Pointer (CBP) SFR. This register contains the number of address locations assigned to the Input channel. The remaining address locations are automatically assigned to the Output FIFO. The CBP SFR can only be programmed by the internal CPU during FIFO DMA Freeze Mode (See FIFO-External Host Interface FIFO DMA Freeze Mode description). The CBP is initialized to 40H (64 bytes) upon reset.

The number in the Channel Boundary Pointer SFR is actually the first address location of the Output FIFO. Writing to the CBP SFR reassigns the Input and Output FIFO address space. Whenever the CBP is written, the Input FIFO pointers are reset to zero and the Output FIFO pointers are set to the value in the CBP SFR.

All of the FIFO space may be assigned to one channel. In such a situation the other channel's data path consists of a single SFR (FIFO IN/COMMAND IN or FIFO OUT/COMMAND OUT SFR) location.

CBP Register	Input FIFO Size	Output FIFO Size
0	1	128
1	1	128
2	2	126
3	3	125
4	4	124
•	•	•
7B	123	5
7C	124	4
7D	125	3
7E	128	1
7F	128	1



FIFO Read/Write Pointers

These normally operate in auto-increment (and auto-rollover) mode, but can be reassigned by the internal CPU during FIFO DMA Freeze Mode (See FIFO-External Host Interface FIFO DMA Freeze Mode description).

Threshold Register

The Input FIFO Threshold SFR contains the number of empty bytes that must be available in the Input FIFO to generate a Host interrupt. The Output FIFO Threshold SFR contains the number of bytes, data and/or DSC(s), that must be in the FIFO before an interrupt is generated. The Threshold feature prevents the Host from being interrupted each time the FIFO needs to load or unload one byte of data. The thresholds, therefore, allow the FIFO's operation to be adjusted to the speed of the Host, optimizing the overall interface performance.

Immediate Commands

The UPI-452 provides, in addition to data and DSCs, a third direct means of communication between the external Host and internal CPU called Immediate Commands. As the name implies, an Immediate Command is available to the receiving CPU immediately, via an interrupt, without being entered into the FIFO as are Data Stream Commands. Like Data Stream Commands, Immediate Commands are written either via a unique external address by the host CPU, or via dedicated SFR by the internal CPU.

The DSC and/or Immediate Command interface may be defined as either Interrupt or Polled under user program control via the Interrupt Enable (IE), Slave Control Register (SLCON), and Interrupt Enable Priority (IEP) Special Function Registers, for the internal CPU and via the Host Control SFR for the external Host CPU.

DMA

The UPI-452 contains a two channel internal DMA controller which allows transfer of data between any

of the three writeable memory spaces: Internal Data Memory, External Load Expansion Bus Data Memory and the Special Function Register array. The Special Function Register array appears as a set of unique dedicated memory addresses which may be used as either the source or destination address of a DMA transfer. Each DMA channel is independently programmable via dedicated Special Function Registers for mode, source and destination addresses, and byte count to be transferred. Each DMA channel has four programmable modes:

- Alternate Cycle Mode
- Burst Mode
- FIFO or Serial Channel Demand Mode
- External Demand Mode

A complete description of each mode and DMA operation may be found in the section titled "General Purpose DMA Channels".

FIFO/SLAVE INTERFACE FUNCTIONAL DESCRIPTION

Overview

The FIFO is a 128 Byte RAM array with recirculating pointers to manage the read and write accesses. The FIFO consists of an Input and an Output channel. Access cycles to the FIFO by the internal CPU and external Host are interleaved and appear to be occurring concurrently to both the internal CPU and external Host. Interleaving access cycles ensures efficient use of this shared resource. The internal CPU accesses the FIFO in the same way it would access any of the Special Function Registers e.g., direct and register indirect addressing as well as arithmetic and logical instructions.

Input FIFO Channel

The Input FIFO Channel provides for data transfer from the external Host to the internal CPU (Figure 5). The registers associated with the Input Channel during normal operation are listed in Table 1*.

Table 1. Input FIFO Channel Registers*

	Register Name	Description
1)	Input Buffer Latch	Host CPU Write only
2)	FIFO IN SFR	Internal CPU Read only
3)	COMMAND IN SFR	Internal CPU Read only
4)	Input FIFO Read Pointer SFR	Internal CPU Read only
5)	Input FIFO Write Pointer SFR	Internal CPU Read only
6)	Input FIFO Threshold SFR	Internal CPU Read only

*See "FIFO-EXTERNAL HOST INTERFACE FIFO DMA FREEZE MODE" section for FIFO DMA Freeze Mode SFR characteristics description.

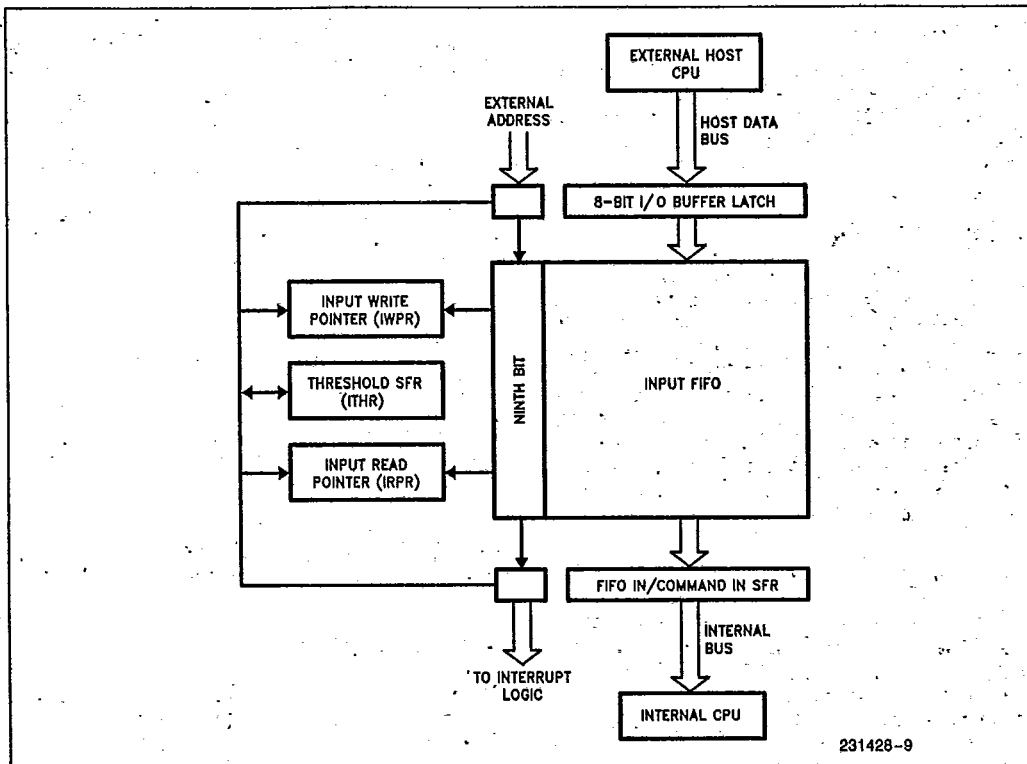

Figure 5. Input FIFO Channel Functional Block Diagram

The host CPU writes data and Data Stream Commands into the Input Buffer Latch on the rising edge of the external WR signal. External addressing determines whether the byte is a data byte or Data Stream Command and the FIFO logic sets the ninth bit of the FIFO accordingly as the byte is moved from the Input Buffer Latch into the FIFO. A "1" in the ninth bit indicates that the incoming byte is a Data Stream Command. The internal CPU reads data bytes via the FIFO IN SFR, and Data Stream Commands via the COMMAND IN SFR.

A Data Stream Command will generate an interrupt to the Internal CPU prior to being read and after completion of the previous operation. The DSC can then be read via the COMMAND IN SFR. Data can only be read via the FIFO IN SFR and Data Stream Commands via the COMMAND IN SFR. Attempting to read Data Stream Commands as data by addressing the FIFO IN SFR will result in "0FFH" being read, and the Input FIFO Read Pointer will remain intact. (This prevents accidental misreading of Data Stream Commands.) Attempting to read data as Data Stream Commands will have the same consequence.

The Input FIFO Channel addressing is controlled by the Input FIFO Read and Write Pointer SFRs. These SFRs are read only registers during normal operation. However, during FIFO DMA Freeze Mode (See FIFO-External Host Interface FIFO DMA Freeze Mode description), the internal CPU has write access to them. Any write to these registers in normal mode will have no effect. The Input Write Pointer SFR contains the address location to which data/commands are written from the Input Buffer Latch. The write pointer is automatically incremented after each write and is reset to zero if equal to the CBP, as the Input FIFO operates as a circular buffer.

If a write is performed on an empty FIFO, the first byte is also written into the FIFO IN or COMMAND IN SFR. If the Host continues writing while the Input FIFO is full, an external interrupt, if enabled, is sent to the host to signal the overrun condition. The writes are ignored by the FIFO control logic. Similarly, an internal CPU read of an empty FIFO will cause an underrun error interrupt to be generated to the internal CPU and a value of "0FFH" will be read by the internal CPU.

The Read Pointer SFR holds the address of the next byte to be read from the Input FIFO. An Input FIFO read operation post-increments the Input Read Pointer SFR and loads a new data byte into the FIFO IN SFR or a Data Stream Command into the COMMAND IN SFR at the end of the read cycle.

An Input FIFO Request for Service (via DMA, Interrupt or a flag) is generated to the Host whenever more data can be written into the Input FIFO. For efficient utilization of the Host, a "threshold" value can be programmed into the Input FIFO Threshold SFR. The range of values of the Input FIFO Threshold SFR can be from 0 to (CBP-3). The Request for Service Interrupt is generated only after the Input FIFO has room to accommodate a threshold number of bytes or more. The threshold is equal to the total

number of bytes assigned to the Input FIFO (CBP) minus the number of bytes programmed in the Input FIFO Threshold SFR. With this feature the Host is assured that it can write at least a threshold number of bytes to the Input FIFO channel without worrying about an overrun condition. Once the Request for Service is generated it remains active until the Input FIFO becomes full.

Output FIFO Channel

The Output FIFO Channel provides data transfer from the UPI-452 internal CPU to the external Host (Figure 6).

The registers associated with the Output Channel during normal operation are listed in Table 2*.

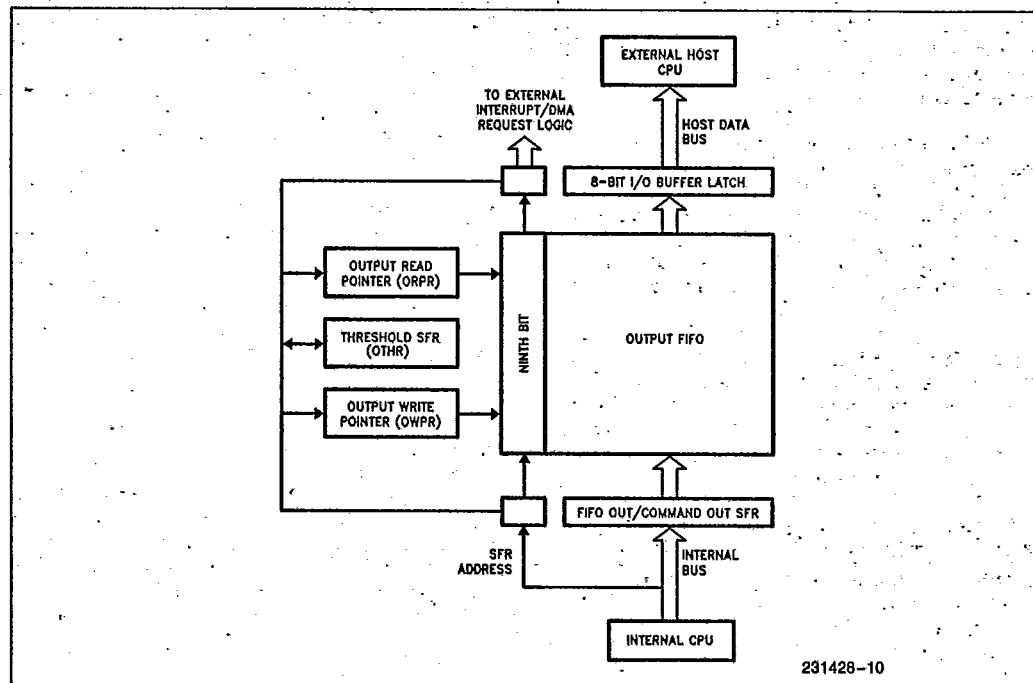

Figure 6. Output FIFO Channel Functional Block Diagram

Table 2. Output FIFO Channel Registers

	Register Name	Description
1)	Output Buffer Latch	Host CPU Read only
2)	FIFO OUT SFR	Internal CPU Read and Write
3)	COMMAND OUT SFR	Internal CPU Read and Write
4)	Output FIFO Read Pointer SFR	Internal CPU Read only
5)	Output FIFO Write Pointer SFR	Internal CPU Read only
6)	Output FIFO Threshold SFR	Internal CPU Read only

*See "FIFO-EXTERNAL HOST INTERFACE FIFO DMA FREEZE MODE" section for FIFO DMA Freeze Mode register characteristics description.



The UPI-452 internal CPU transfers data to the Output FIFO via the FIFO OUT SFR and commands via the COMMAND OUT SFR. If the byte is written to the COMMAND OUT SFR, the ninth bit is automatically set (=1) to indicate a Data Stream Command. If the byte is written to the FIFO OUT SFR the ninth bit is cleared (=0). Thus the FIFO OUT and COMMAND OUT SFRs are the same but the address determines whether the byte entered in the FIFO is a DSC or data byte.

The Output FIFO preloads a byte into the Output Buffer Latch. When the Host issues a RD/ signal, the data is immediately read from the Output Buffer Latch. The next data byte is then loaded into the Output Buffer Latch, a flag is set and an interrupt, if enabled, is generated if the byte is a DSC (ninth bit is set). The operation is carefully timed such that an interrupt can be generated in time for it to be recognized by the Host before its next read instruction. Internal CPU write and external Host read operations are interleaved at the FIFO so that they appear to be occurring concurrently.

The Output FIFO read and write pointer operation is the same as for the Input Channel. Writing to the FIFO OUT or COMMAND OUT SFRs will increment the Output Write Pointer SFR but reading from it will leave the write pointer unchanged. A rollover of the Output FIFO Write Pointer causes the pointer to be reset to the value in the Channel Boundary Pointer (CBP) SFR.

If the external host attempts to read a Data Stream Command as a data byte it will result in invalid data (0FFH) being read. The DSC is not lost because the invalid read does not increment the pointer. Similarly attempting to read a data byte as a Data Stream Command has the same result.

A Request for Service is generated to the external Host under the following two conditions:

- 1.) Whenever the internal CPU has written a threshold number of bytes or more into the Output FIFO (threshold = (OTHR) + 1). The threshold number should be chosen such that the bus latency time for the external Host does not result in a FIFO overrun error condition on the internal CPU side. The threshold limit should be large enough to make a bus request by the UPI-452 to the external host CPU worthwhile. Once a request for service is generated, the request remains active until the Output FIFO becomes empty. The range of values of the FIFO Output Threshold (OTHR) SFR is from 2 to $\{(80H-CBP)-1\}$. The threshold number can be programmed via the OTHR SFR.

- 2.) The second type of Request for Service is called "Flush Mode" and occurs when the internal CPU writes a Data Stream Command into the Output FIFO. Its purpose is to ensure that a data block entered into the Output FIFO, which is less than the programmed threshold, will generate a Request for Service interrupt, if enabled, and be read, or "Flushed" from the Output FIFO, by the external host CPU regardless of the status of the OTHR SFR.

Immediate Commands

Immediate Commands provide direct communication between the external Host and UPI-452. Unlike Data Stream Commands which are entered into the FIFO, the Immediate Command is available to the receiving CPU directly, bypassing the FIFO. The Immediate Command can serve as a program vector pointing into a jump table in the recipients software. Immediate Command Interrupts are generated, if enabled, and a bit in the appropriate Status Register is set when an Immediate Command is input or output. A similar bit is provided to acknowledge when an Immediate Command has been read and whether the register is available to receive another command. The bits are reset when the Immediate Commands are read. Two Special Function Registers are dedicated to the Immediate Command interface. External addressing determines whether the Host is accessing the Input FIFO or the Immediate Command IN (IMIN) SFR. The internal CPU writes Immediate Commands to the Immediate Command OUT (IMOUT) SFR.

Both processors have the ability to enable or disable Immediate Command Interrupts. By disabling the interrupt, the recipient of the Immediate Command can poll the status SFR and read the Immediate Command at its convenience. Immediate Commands should only be written when the appropriate Immediate Command SFR is empty (as indicated in the appropriate status SFR:HSTAT/SSTAT). Similarly, the Immediate Command SFR should only be read when there is data in the Register.

The flowcharts in Figure 7a and 7b illustrate the proper handshake mechanisms between the external Host and internal CPU when handling Immediate Commands.

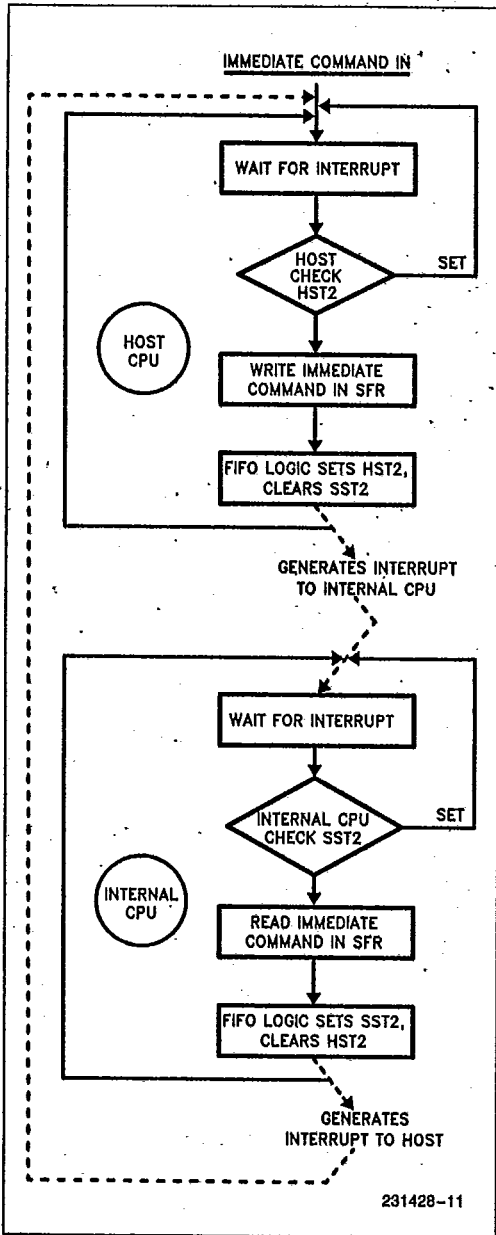

Figure 7a. Handshake Mechanisms for Handling Immediate Command IN Flowchart

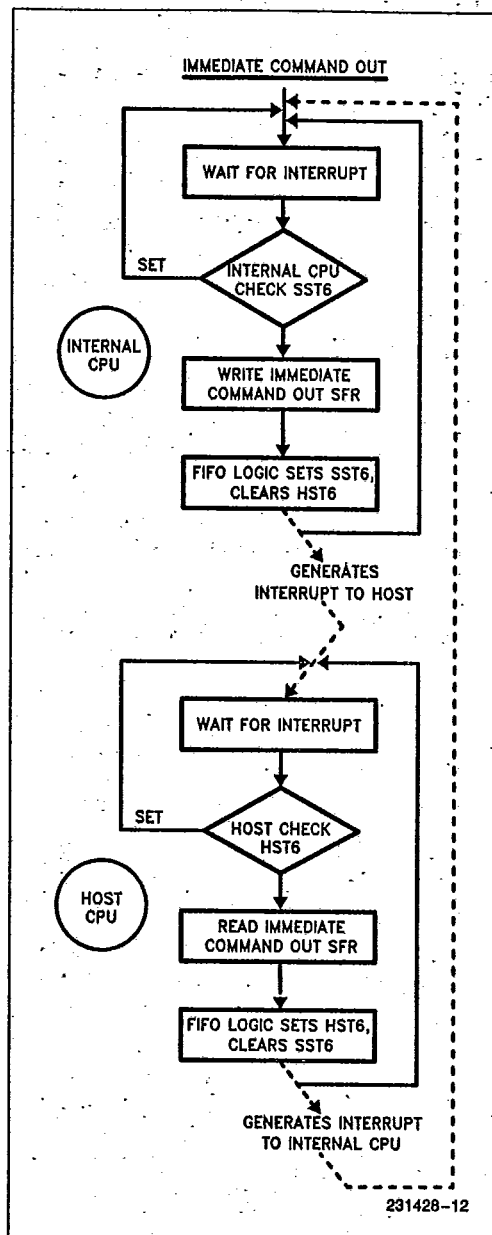

Figure 7b. Handshake Mechanisms for Handling Immediate Command OUT Flowchart



HOST & SLAVE INTERFACE SPECIAL FUNCTION REGISTERS

Slave Interface Special Function Registers

The Internal CPU interfaces with the FIFO slave module via the following registers:

- 1) Mode Special Function Register (MODE)
- 2) Slave Control Special Function Register (SLCON)
- 3) Slave Status Special Function Register (SSTAT)

Each register resides in the SFR Array and is accessible via all direct addressing modes except bit. Only the Slave Control Register (SLCON) is bit addressable.

1) MODE Special Function Register (MODE)

The MODE SFR provides the primary control of the external host-FIFO interface. It is included in the SFR Array so that the internal CPU can configure the external host-FIFO interface should the user decide that the UPI-452 slave initialize itself independent of the external host CPU.

The MODE SFR can be directly modified by the internal CPU through direct address instructions. It can also be indirectly modified by the external host CPU by setting up a MODE SFR service routine in the UPI-452 program memory and having the host issue a Command, either immediate or DSC, to vector to that routine.

**Symbolic
Address**

**Physical
Address**

Symbolic Address	Physical Address								
MODE	—	MD6	MD5	MD4	—	—	—	—	0F9H
	(MSB)							(LSB)	
	Status On Reset:								
	1*	0	0	0	1*	1*	1*	1*	

MD7 (reserved)**

MD6 Request for Service to external CPU via;

1 = DMA (DRQIN/DRQOUT) request to external host when the Input or Output FIFO channel requests service

0 = Interrupt (INTRQIN/INTRQOUT or INTRQ) to external host when the Input or Output FIFO channel requests service or a DSC is encountered in the I/O Buffer Latch

MD5 Configure DRQIN/INTRQIN and DRQOUT/INTRQOUT to be either;

1 = Enable (Actively driven)

0 = Disable (Tri-state)

MD4 Configure INTRQ to be either;

1 = Enable (Actively driven)

0 = Disable (Tri-state)

MD3 (reserved) **

MD2 (reserved) **

MD1 (reserved) **

MD0 (reserved) **

2) Slave Control SFR (SLCON)

The Slave Control SFR is used to configure the FIFO-internal CPU interface. All interrupts are to the internal CPU.



Symbolic Address

Physical Address

SLCON	IFI	OFI	ICII	ICOI	FRZ	—	IFRS	OFRS	0E8H
-------	-----	-----	------	------	-----	---	------	------	------

(MSB) (LSB)

Status On Reset:

0	0	0	0	0	0	1*	0	0
---	---	---	---	---	---	----	---	---

- IFI Enable Input FIFO Interrupt (due to Underrun Error Condition, Data Stream Command or Request Service)
 - 1 = Enable
 - 0 = Disable
- OFI Enable Output FIFO Interrupt (due to Overrun Error Condition or Request Service)
 - 1 = Enable
 - 0 = Disable

Note: If the DMA is configured to service a FIFO demand, then the Request for Service Interrupt is not generated.
- ICII Generate Interrupt when a command is written to the Immediate Command in Register
 - 1 = Enable
 - 0 = Disable
- ICOI Generate Interrupt when Immediate Command Out Register is Available
 - 1 = Enable
 - 0 = Disable
- FRZ Enable FIFO DMA Freeze Mode
 - 1 = Normal operation
 - 0 = FIFO DMA Freeze Mode
- SC2 (reserved) **
- IFRS Input FIFO Channel Request for Service
 - 1 = Request when Input FIFO not empty
 - 0 = Request when Input FIFO full
- OFRS Output FIFO Channel Request for Service
 - 1 = Request when Output FIFO not full
 - 0 = Channel Request when Output FIFO empty



NOTES:

*A '1' will be read from all SFR reserved locations except HCON SFR, HC0 and HC2.
 **'reserved'—these locations are reserved for future use by Intel Corporation.

3) Slave Status SFR (SSTAT)

The bits in the Slave Status SFR reflect the status of the FIFO-internal CPU interface. It can be read during an internal interrupt service routine to determine the nature of the interrupt or read during a polling sequence to determine a course of action.

Symbolic Address

Physical Address

SSTAT	SST7	SST6	SST5	SST4	SST3	SST2	SST1	SST0	0E9H
-------	------	------	------	------	------	------	------	------	------

← Output FIFO Status → ← Input FIFO Status →

Status On Reset:

1	0	0	0	1	1	1	1
---	---	---	---	---	---	---	---

(MSB)

(LSB)



- SST7 Output FIFO Overrun Error Condition
 1 = No Error
 0 = Error (latched until Slave Status SFR is read)
- SST6 Immediate Command Out Register Status
 1 = Full (i.e. Host CPU has not read previous Immediate Command Out sent by internal CPU)
 0 = Available
- SST5 FIFO DMA Freeze Mode Status
 1 = Normal Operation
 0 = FIFO DMA Freeze Mode in Progress
- SST4 Output FIFO Request for Service Flag
 1 = Output FIFO does not request service
 0 = Output FIFO requests service
- SST3 Input FIFO Underrun Error Condition Flag
 1 = No Underrun Error
 0 = Underrun Error (latched until Slave Status SFR is read)
- SST2 Immediate Command In SFR Status
 1 = Empty
 0 = Immediate Command received from host CPU
- SST1 Data Stream Command/Data at Input FIFO Flag
 1 = Data (not DSC)
 0 = DSC (at COMMAND IN SFR)
- SST0 Input FIFO Request For Service Flag
 1 = Input FIFO Does Not Request Service
 0 = Input FIFO Request for Service

EXTERNAL HOST INTERFACE SPECIAL FUNCTION REGISTERS

The external host CPU has direct access to the following SFRs:

- 1) Host Control Special Function Register
- 2) Host Status Special Function Register

It can also access other SFRs by commanding the internal CPU to change them accordingly via Data Stream Commands or Immediate Commands. The protocol for implementing this is entirely determined by the user.

1) Host Control SFR (HCON)

By writing to the Host Control SFR, the host can enable or disable FIFO interrupts and DMA requests and can reset the UPI-452.

Symbolic
Address

HCON

HC7	HC6	HC5	HC4	HC3	—	HC1	—
(MSB)				(LSB)			
Status On Reset:							
0	0	0	0	0	0*	0	0*

Physical
Address

0E7H



- HC7 Enable Output FIFO Interrupt due to Underrun Error Condition, Data Stream Command or Service Request
 1 = Enable
 0 = Disable
- HC6 Enable Input FIFO Interrupt due to Overrun Error Condition, or Service Request
 1 = Enable
 0 = Disable
- HC5 Enable the generation of the Interrupt due to Immediate Command Out being present
 1 = Enable
 0 = Disable
- HC4 Enable the Interrupt due to the Immediate Command In Register being Available for a new Immediate Command byte
 1 = Enable
 0 = Disable
- HC3 Reset UPI-452
 1 = Software RESET
 0 = Normal Operation
- HC2 (reserved) **
- HC1 Select between INTRQ and INTRQIN/INTRQOUT as Request for Service interrupt signal when DMA is disabled
 1 = INTRQ
 0 = INTRQIN or INTRQOUT
- HC0 (reserved) **

NOTES:

*A '1' will be read from all SFR reserved locations except HCON SFR, HC0 and HC2.

**reserved—these locations are reserved for future use by Intel Corporation.

2) Host Status SFR (HSTAT)

The Host Status SFR provides information on the FIFO-Host Interface and can be used to determine the source of an external interrupt during polling. Like the Slave Status SFR, the Host Status SFR reflects the current status of the FIFO-external host interface.

Symbolic
Address

Physical
Address

HSTAT

0E6H

HST7	HST6	HST5	HST4	HST3	HST2	HST1	HST0
← Output FIFO Status →				← Input FIFO Status →			
Status On Reset:							
1	1	1	1	1	1/0*	1	1
(MSB)				(LSB)			



- HST7** Output FIFO Underrun Error Condition
 1 = No Underrun Error
 0 = Underrun Error (latched until Host Status Register is read)
- HST6** Immediate Command Out SFR Status
 1 = Empty
 0 = Immediate Command Present
- HST5** Data Stream Command/Data at Output FIFO Status
 1 = Data (not DSC)
 0 = DSC (present at Output FIFO COMMAND OUT SFR)
 (Note: Only if HST4=0, if HST4=1 then undetermined)
- HST4** Output FIFO Request for Service Status
 1 = No Request for Service
 0 = Output FIFO Request for Service due to:
 a. Output FIFO containing the threshold number of bytes or more
 b. Internal CPU sending a block of data terminated by a DSC (DSC Flush Mode)
- HST3** Input FIFO Overrun Error Condition
 1 = No Overrun Error
 0 = Overrun Error (latched until Host Status Register is read)
- HST2** Immediate Command In SFR Status
 1 = Full (i.e. Internal CPU has not read previous Immediate Command sent by Host)
 0 = Empty
 * Reset value;
 '1' — If read by the external Host
 '0' — if read by internal CPU (reads shadow latch - see FIFO DMA Freeze Mode description)
- HST1** FIFO DMA Freeze Mode Status
 1 = Freeze Mode in progress.
 (In Freeze Mode, the bits of the Host Status SFR are forced to a '1' initially to prevent the external Host from attempting to access the FIFO. The definition of the Host Status SFR bits during FIFO DMA Freeze Mode can be found in FIFO DMA Freeze Mode description)
 0 = Normal Operation
- HST0** Input FIFO Request Service Status
 1 = Input FIFO does not request service
 0 = Input FIFO request service due to the Input FIFO containing enough space for the host to write the threshold number of bytes or more

FIFO MODULE - EXTERNAL HOST INTERFACE

Overview

The FIFO-external Host interface supports high speed asynchronous bi-directional 8-bit data transfers. The host interface is fully compatible with Intel microprocessor local busses and with MULTIBUS. The FIFO has two specialized DMA request pins for Input and Output FIFO channel DMA requests. These are multiplexed to provide a dedicated Request for Service interrupt (DRQIN/INTRQIN, DRQOUT/INTRQOUT).

The external Host can program, under user defined protocol, thresholds into the FIFO Input and Output Threshold SFRs which determine when the FIFO Request for Service interrupt is generated to the Host CPU. The FIFO module external Host interface is configured by the internal CPU via the MODE SFR. "The external Host can enable and disable Host interface interrupts via the Host Control SFR." Data Stream Commands in the Input FIFO channel allow the Host to influence the processing of data blocks and are sent with the data flow to maintain synchronization. Data Stream Commands in the Output FIFO Channel allow the internal CPU to perform the same function, and also to set the Output FIFO Request Service status logic to the host CPU regardless of the programmed value in the Threshold SFR.

Slave Interface Address Decoding

The UPI-452 determines the desired Host function through address decoding. The lower three bits of the address as well as the READ, WRITE, Chip Select (\overline{CS}) and DMA Acknowledge (\overline{DACK}) are used for decoding. Table 3 shows the pin states and the Read or Write operations associated with each configuration.

Interrupts to the Host

The UPI-452 interrupts the external Host via the INTRQ pin. In addition, the DRQIN and DRQOUT pins can be multiplexed as interrupt request lines, INTRQIN and INTRQOUT respectively, when DMA is disabled. This provides two special FIFO "Request for Service" interrupts.

There are eight FIFO-related interrupt sources; two from The Input FIFO; three from The Output FIFO; one from the Immediate Command Out SFR; one from the Immediate Command IN SFR; and one due to FIFO DMA Freeze Mode.

INPUT FIFO: The Input FIFO interrupt is generated whenever:

- a. The Input FIFO contains space for a threshold number of bytes.



Table 3. UPI-452 Address Decoding

DACK	CS	A2	A1	A0	Read	Write
1	1	X	X	X	No Operation	No Operation
1	0	0	0	0	Data or DMA from Output FIFO Channel	Data or DMA to Input FIFO Channel
1	0	0	0	1	Data Stream Command from Output FIFO Channel	Data Stream Command to Input FIFO Channel
1	0	0	1	0	Host Status SFR Read	Reserved
1	0	0	1	1	Host Control SFR Read	Host Control SFR Write
1	0	1	0	0	Immediate Command SFR Read	Immediate Command to SFR Write
1	0	1	1	X	Reserved	Reserved
0	X	X	X	X	DMA Data from Output FIFO Channel	DMA Data to Input FIFO Channel
1	0	1	0	1	Reserved	Reserved

NOTES:

1. Attempting to read a DSC as a data byte will result in invalid data being read. The read pointers are not incremented so that the DSC is not lost. Attempting to read a data byte as a DSC has the same result.

2. If DACK is active the UPI-452 will attempt a DMA operation when RD or WR becomes active regardless of the DMA enable bit (MD6) in the MODE SFR. Care should be taken when using DACK. For proper operation, DACK must be driven high (+5V) when not using DMA.

b. When an Input FIFO overrun error condition exists. The appropriate bits in the Host Status SFR are set and the interrupt is generated only if enabled.

OUTPUT FIFO: The Output FIFO Request for Service Interrupt operates in a similar manner as the Input FIFO interrupt:

- When the FIFO contains the threshold number of bytes or more.
- Output FIFO error condition interrupts are generated when the Output FIFO is underrun.
- Data Stream Command present in the Output Buffer Latch.

A Data Stream Command interrupt is used to halt normal processing, using the command as a vector to a service routine. When DMA is disabled, the user may program (through HC1) INTRQ to include FIFO Request for Service Interrupts or use INTRQIN and INTRQOUT as Request for Service Interrupts.

IMMEDIATE COMMAND INTERRUPTS:

- An Immediate Command Out Interrupt is generated, if enabled, to the Host and the corresponding Host Status SFR bit (HSTAT HST6) is cleared, when the internal CPU writes to the Immediate Command OUT (IMOUT) SFR. When the Host reads the Immediate Command OUT (IMOUT) SFR the corresponding bit in the Host Status (HSTAT) SFR is set. This causes the Slave Status Immediate Command OUT Status bit (SSTAT SST6) to be cleared indicating that the Immediate Command OUT (IMOUT) SFR is empty. If enabled, a FIFO-Slave Interface will also be generated to the internal CPU. (See Figure 7b, Immediate Command OUT Flowchart.)

- An Immediate Command IN interrupt is generated, if enabled, to the Host when the internal CPU has read a byte from the Immediate Command IN (IMIN) SFR. The read operation clears the Host Status SFR Immediate Command IN Status bit (HSTAT HST2) indicating that the Immediate Command IN SFR is empty. The corresponding Slave Status (SSTAT) SFR bit is also set to indicate an empty status. Setting the Slave Status SFR bit generates a FIFO-Slave Interface interrupt, if enabled, to the internal CPU. (See Figure 7a, Immediate Command IN Flowchart.)

NOTE:

Immediate Command IN and OUT interrupts are actually specific Request For Service interrupts to the Host.

FIFO DMA FREEZE MODE: When the internal CPU invokes FIFO DMA Freeze Mode, for example at reset or to reconfigure the FIFO interface, INTRQ is activated. The INTRQ can only be deactivated by the external Host reading the Host Status SFR (HST1 remains active until FIFO DMA Freeze Mode is disabled by the internal CPU).

Once an interrupt is generated, INTRQ will remain high until no interrupt generating condition exists. For a FIFO underrun/overrun error interrupt, the interrupt condition is deactivated by the external Host reading the Host Status SFR. An interrupt is serviced by reading the Host Status SFR to determine the source of the interrupt and vectoring the appropriate service routine.



DMA Requests to the Host

The UPI-452 generates two DMA requests, DRQIN and DRQOUT, to facilitate data transfer between the Host and the Input and Output FIFO channels. A DMA acknowledge, DACK, is used as a chip select and initiates a data transfer. The external READ and WRITE signals select the Input and Output FIFO respectively. The CS and address lines can also be used as a DMA acknowledge for processors with onboard DMA controllers which do not generate a DACK signal.

The internal CPU can configure the UPI-452 to request service from the external host via DMA or interrupts by programming Mode SFR MD6 bit. In addition the external Host enables DMA requests through bits 6 and 7 of the Host Control SFR. When a DMA request is invoked the number of bytes transferred to the Input FIFO is the total number of bytes in the Input FIFO (as determined by the CBP SFR) minus the value programmed in the Input FIFO Threshold SFR. The DMA request line is activated only when the Input FIFO has a threshold number of bytes that can be transferred.

The Output FIFO DMA request is activated when a DSC is written by the internal CPU at the end of a less than threshold size block of data (Flush Mode) or when the Output FIFO threshold is reached. The request remains active until the Input FIFO becomes full or the Output FIFO becomes empty. If a DSC is encountered during an Output FIFO DMA transfer, the DMA request is dropped until the DSC is read. The DMA request will be reactivated after the DSC is read and remains active until the Output FIFO becomes empty or another DSC is encountered.

FIFO MODULE - INTERNAL CPU INTERFACE

Overview

The Input and Output FIFOs are accessed by the internal CPU through direct addressing of the FIFO IN/COMMAND IN and FIFO OUT/COMMAND OUT Special Function Registers. All of the 80C51 instructions involving direct addressing may be used to access the FIFO's SFRs. The FIFO IN, COMMAND IN and Immediate Command In SFRs are actually read only registers, and their Output counterparts are write only. Internal DMA transfers data between internal memory, External Memory and the Special Function Registers. The Special Function Registers appear as another group of dedicated memory addresses and are programmed as the source or desti-

nation via the DMA0/DMA1 Source Address or Destination Address Special Function Registers. The FIFO module manages the transfer of data between the external host and FIFO SFRs.

Internal CPU Access to FIFO Via Software Instructions

The internal CPU has access to the Input and Output FIFOs via the FIFO IN/COMMAND IN and FIFO OUT/COMMAND OUT SFRs which reside in the Special Function Register Array. At the end of every instruction that involves a read of the FIFO IN/COMMAND IN SFR, the SFR is written over by a new byte from the Input FIFO channel when available. At the end of every instruction that involves a write to the FIFO OUT/COMMAND OUT SFR, the new byte is written into the Output FIFO channel and the write pointer is incremented after the write operation (post incremented).

The internal CPU reads the Input FIFO by using the FIFO IN/COMMAND IN SFR as the source register in an instruction. Those instructions which read the Input FIFO are listed below:

```
ADD A,FIFO IN/COMMAND IN
ADDC A,FIFO IN/COMMAND IN
PUSH FIFO IN/COMMAND IN
ANL A,FIFO IN/COMMAND IN
ORL A,FIFO IN/COMMAND IN
XRL A,FIFO IN/COMMAND IN
CJNE A,FIFO IN/COMMAND IN, rel
SUBB A,FIFO IN/COMMAND IN
MOV direct,FIFO IN/COMMAND IN
MOV @Ri,FIFO IN/COMMAND IN
MOV Rn,FIFO IN/COMMAND IN
MOV A,FIFO IN/COMMAND IN
```

After each access to these registers, they are overwritten by a new byte from the FIFO.

NOTE:

Instructions which use the FIFO IN or COMMAND IN SFR as both a source and destination register will have the data destroyed as the next data byte is rewritten into the FIFO IN register at the end of the instruction. These instructions are not supported by the UPI-452 FIFO. Data can only be read through the FIFO IN SFR and DSCs through the COMMAND IN SFR. Data read through the COMMAND IN SFR will be read as 0FFH, and DSCs read through the FIFO IN SFR will be read as 0FFH. The Immediate Command in SFR is read with the same instructions as the FIFO IN and COMMAND IN SFRs.



The FIFO IN, COMMAND IN and Immediate Command In SFRs are read only registers. Any write operation performed on these registers will be ignored and the FIFO pointers will remain intact.

The internal CPU uses the FIFO OUT SFR to write to the Output FIFO and any instruction which uses the FIFO OUT or COMMAND OUT SFR as a destination will invoke a FIFO write. DSCs are differentiated from data by writing to the COMMAND OUT SFR. In the FIFO, Data Stream Commands have the ninth bit associated with the command byte set to "1". The instructions used to write to the Output FIFO are listed below:

```
MOV FIFO OUT/COMMOUT, A
MOV FIFO OUT/COMMOUT, direct
MOV FIFO OUT/COMMOUT, Rn
POP FIFO OUT/COMMOUT
MOV FIFO OUT/COMMOUT, #data
MOV FIFO OUT/COMMOUNT, @Ri
```

NOTE:

Instructions which use the FIFO OUT/COMMAND OUT SFRs as both a source and destination register cause invalid data to be written into the Output FIFO. These instructions are not supported by the UPI-452 FIFO.

GENERAL PURPOSE DMA CHANNELS**Overview**

There are two identical General Purpose DMA Channels on the UPI-452 which allow high speed data transfer from one writeable memory space to another. As many as 64K bytes can be transferred in a single DMA operation. The following memory spaces can be used with DMA channels:

- Internal Data Memory
- External Data Memory
- Special Function Registers

The Special Function Register array appears as a limited group of dedicated memory addresses. The Special Function Registers may be used in DMA transfer operations by specifying the SFR as the source or destination address. The Special Function Registers which may be used in DMA transfers are listed in Table 4. Table 4 also shows whether the SFR may be used as Source or Destination only, or both.

The FIFO can be accessed during DMA by using the FIFO IN SFR as the DMA Source Address Register (SAR) or the FIFO OUT SFR as the Destination Ad-

dress Register (DAR). (Note: Since the FIFO IN SFR is a read only register, the DMA transfer will be ignored if it is used as a DMA DAR. This is also true if the FIFO OUT SFR is used as a DMA SAR.)

Each DMA channel is software programmable to operate in either Block Mode or Demand Mode. In the Block Mode, DMA transfers can be further programmed to take place in Burst Mode or Alternate Cycle mode. In Burst Mode, the processor halts its execution and dedicates its resources to the DMA transfer. In Alternate Cycle Mode, DMA cycles and instruction cycles occur alternately.

In Demand Mode, a DMA transfer occurs only when it is demanded. Demands can be accepted from an external device (through External Interrupt pins, EXT0/EXT1) or from either the Serial Channel or FIFO flags. In this way, a DMA transfer can be synchronized to an external device, the FIFO or the Serial Port. If the External Interrupt is configured in Edge Mode, a single byte transfer occurs per transition. The external interrupt itself will occur if enabled. If the External Interrupt is configured in Level Mode, DMA transfers continue until the External Interrupt request goes inactive or the byte count becomes zero. The following flags activate Demand Mode transfers of one byte to/from the FIFO or Serial Channel:

- RI - Serial Channel Receiver Buffer Full
- TI - Serial Channel Transmitter Buffer Empty

Architecture

There are three 16 bit and one 8 bit Special Function Registers associated with each DMA channel.

- The 16 bit Source Address SFR (SAR) points to the source byte.
- The 16 bit Destination Address SFR (DAR) points to the destination.
- The 16 bit Byte Count SFR (BCR) contains the number of bytes to be transferred and is decremented when a byte transfer is accomplished.
- The DMA Control SFR (DCON) is eight bits wide and specifies the source memory space, destination memory space and the mode of operation.

In Auto Increment mode, the Source Address and/or Destination Address is incremented when a byte is transferred. When a DMA transfer is complete (BCR = 0), the DONE bit is set and a maskable interrupt is generated. The GO bit must be set to start any DMA transfer (also, the Slave Control SFR FRZ bit must be set to disable FIFO DMA Freeze Mode). The two DMA channels are designated as DMA0 and DMA1, and their corresponding registers are suffixed by 0 or 1; e.g. SAR0, DAR1, etc.



Table 4. DMA Accessible Special Function Registers

SFR	Symbol	Address	Source Only	Destination Only	Either
Accumulator	A/ACC	0E0H			Y
B Register	B	0F0H			Y
FIFO IN	FIN	0EEH	Y		
COMMAND IN	CIN	0EFH	Y		
FIFO OUT	FOUT	0FEH		Y	
COMMAND OUT	COUT	0FFH		Y	
Serial Data Buffer	SBUF	099H			Y
Port 0	P0	080H			Y
Port 1	P1	090H			Y
Port 2	P2	0A0H			Y
Port 3	P3	0B0H			Y
Port 4	P4	0C0H			Y

DMA Special Function Registers

DMA Control SFR: DCON0, DCON1

Symbolic
AddressPhysical
Address

DCON0	DAS	IDA	SAS	ISA	DM	TM	DONE	GO	092H
DCON1	DAS	IDA	SAS	ISA	DM	TM	DONE	GO	093H

(MSB)

(LSB)

Reset Status: DCON0 and DCON1 = 00H

Bit Definition:

DAS	IDA	Destination Address Space
0	0	External Data Memory without Auto-Increment
0	1	External Data Memory with Auto-Increment
1	0	Special Function Register
1	1	Internal Data Memory

SAS	ISA	Source Address Space
0	0	External Data Memory without Auto-Increment
0	1	External Data Memory with Auto-Increment
1	0	Special Function Register
1	1	Internal Data Memory

DM	TM	DMA Transfer Mode
0	0	Alternate-Cycle Transfer Mode
0	1	Burst Transfer Mode
1	0	FIFO or Serial Channel Demand Mode
1	1	External Demand Mode

**DONE DMA transfer Flag:**

- 0 DMA transfer is not completed.
- 1 DMA transfer is complete.

NOTE:

This flag is set when contents of the Byte Count SFR decrements to zero. It is reset automatically when the DMA vectors to its interrupt routine.

GO Enable DMA Transfer:

- 0 Disable DMA transfer (in all modes).
- 1 Enable DMA transfer. If the DMA is in the Block mode, start DMA transfer if possible. If it is in the Demand mode, enable the channel and wait for a demand.

NOTE:

The GO bit is reset when the BCR decrements to zero.

DMA Transfer Modes

The following four modes of DMA operation are possible in the UPI-452.

1. ALTERNATE-CYCLE MODE**General**

Alternate cycle mode is useful when CPU processing must occur during the DMA transfers. In this mode, a DMA cycle and an instruction cycle occur alternately. The interrupt request is generated (if enabled) at the end of the process, i.e. when BCR decrements to zero. The transfer is initiated by setting the GO bit in the DCON SFR.

Alternate-Cycle FIFO Demand Mode

Alternate cycle demand mode is useful for FIFO transfers of a less urgent nature. As mentioned before, CPU instruction cycles are interleaved with DMA transfer cycles, allowing true parallel processing.

This mode differs from FIFO Demand Mode in that CPU instruction cycles must be interleaved with DMA transfers, even if the FIFO is demanding DMA. In FIFO Demand Mode, CPU cycles would never occur if the FIFO demand was present.

Input Channel

The DMA is configured as in FIFO Demand Mode and transfers are initiated whenever an Input FIFO

service request is generated. DMA transfer cycles are alternated with instruction execution cycles. DMA transfers are terminated as in FIFO Demand Mode.

Output Channel

The DMA is configured as in FIFO Demand Mode and transfers are initiated whenever an Output FIFO requests service. DMA transfer cycles are alternated with instruction execution cycles. DMA transfers are terminated as in FIFO Demand Mode.

The FIFO logic resets the interrupt flag after transferring the byte, so the interrupt is never generated.

Once the DMA is programmed to service the FIFO, the request for service interrupt for the FIFO is inhibited until the DMA is done (BCR = 0).

2. BURST MODE

In BURST mode the DMA is initiated by setting the GO bit in the DCON SFR. The DMA operation continues until BCR decrements to zero (zero byte count), then an interrupt is generated (if enabled). No interrupts are recognized during this DMA operation once it has started.

Input Channel

The FIFO Input Channel can be used in burst mode by specifying the FIFO IN SFR as the DMA Source Address. DMA transfers begin when the GO bit in the DMA Control SFR is set. The number of bytes to be transferred must be specified in the Byte Count SFR (BCR) and auto-incrementing of the SAR must be disabled. Once the GO bit is set nothing can interrupt the transfer of data until the BCR is zero. In this mode, a Data Stream Command encountered in the FIFO will be held in the COMMAND IN SFR with the pointers frozen, and invalid data (FFH) will be read through the FIFO IN SFR. If the input FIFO becomes empty during the block transfer, an 0FFH will be read until BCR decrements to zero.

Output Channel

The Output FIFO Channel can be used in burst mode by specifying the FIFO OUT or COMMAND OUT SFR as the DMA Destination Address. DMA transfers begin when the GO bit is set. This mode can be used to send a block of data or a block of Data Stream Commands. If the FIFO becomes full during the block transfer, the remaining data will be lost.

**NOTE:**

All interrupts including FIFO interrupts are not recognized in Burst Mode. Burst Mode transfers should be used to service the FIFO only when the user is certain that no Data Stream Commands are in the block to be transferred (Input FIFO) and that the FIFO contains enough space to store the block to be transferred. In all other cases Alternate Cycle or Demand Mode should be used.

3. FIFO AND SERIAL CHANNEL DEMAND MODES

NOTES:

1. If the output FIFO is configured as a one byte buffer and the user program consists of two-cycle instructions only, then Alternate-Cycle Mode should be used.
2. In non-auto increment mode for internal to external, or external to internal transfers, the lower 8 bits of the external address should not correspond to the FIFO or Serial Port address.

FIFO Demand Mode

Although any DMA mode is possible using the FIFO buffer, only FIFO Demand and Alternate Cycle FIFO Demand Modes are recommended. FIFO Demand Mode DMA transfers using the input FIFO Channel are set-up by setting the GO bit and specifying the FIFO IN register as the DMA Source Address Register. The BCR should be set to the maximum number of expected transfers. The user must also program bit 1 of the Slave Control Register (SC1) to determine whether the Slave Status (SSTAT) SFR FIFO Request For Service Flag will be activated when the FIFO becomes not empty or full. Once the Request For Service Flag is activated by the FIFO, the DMA transfer begins, and continues until the request flag is deactivated. While the request is active, nothing can interrupt the DMA (i.e. it behaves like burst mode). The DMA Request is held active until one of the following occurs:

- 1) The FIFO becomes empty.
- 2) A Data Stream Command is encountered (this generates a FIFO interrupt and DMA operation resumes after the Data Stream Command is read).
- 3) BCR = 0 (this generates a DMA interrupt and sets the DONE bit).

DMA transfers to the Output FIFO Channel are similar. The FIFO OUT or COMMAND OUT SFR is the DMA Destination Address SFR and a transfer is started by setting the GO bit. The user programs bit 0 of the Slave Control SFR (SC0) to determine whether a demand occurs when the Output FIFO

is not full or empty. DMA transfers begin when the Request For Service Flag is activated by the FIFO logic and continue as long as the flag is active. The Flag remains active until one of the following occurs:

- 1) The FIFO becomes full
- 2) BCR = 0 (this generates a DMA interrupt and sets the DONE bit).

As in Alternate Cycle FIFO Demand Mode, the FIFO logic resets the interrupt flag after transferring the byte, so the interrupt is never generated.

After the GO bit is set, the DMA is activated if one of the following conditions takes place:

- SAR(0/1) = FIFO IN and HIFRS flag is set
- DAR(0/1) = FIFO OUT and HOFRS flag is set

The HIFRS and HOFRS signals are internal flags which are not accessible by software. These flags are similar to the SST0 and SST4 flags in the Slave Status Register except that they are of the opposite polarity and once set they are not cleared until the Input FIFO becomes empty (HIFRS) or the Output FIFO becomes full (HOFRS).

Serial Channel Demand Mode

Serial Channel Demand Mode is the logical choice when using the Serial Port. The DMAs can be activated by one of the Serial Channel Flags. Receiver Interrupt (RI) or Transmitter Interrupt (TI).

- SAR(0/1) = SBUF and RI flag is set
- DAR(0/1) = SBUF and TI flag is set

NOTE:

TI flag must be set by software to initiate the first transfer.

When the DMA transfer begins, only one byte is transferred at a time. The serial port hardware automatically resets the flag after completion of the transfer, so an interrupt will not be generated unless DMA servicing is held off due to the DMA being done (BCR = 0) or when the Hold/Hold Acknowledge logic is used and the DMA does not own the bus. In this case a Serial Port Interrupt may be generated if enabled because of the status of the RI or TI flags.

In FIFO demand mode, Alternate cycle FIFO demand mode or Serial Port demand mode only one of the following registers (SBUF, FIN or FOUT) should be used as either the SAR or DAR registers to prevent undesired transfers. For example if SAR0 = FIN and DAR0 = SBUF in demand mode, the DMA transfer will start if either the HIFRS or TI flags are set.



4. EXTERNAL DEMAND MODE

The DMA can be initiated by an external device via External interrupt 0 and 1 (INT0/INT1) pins. The INT0 pin demands DMA0 (Channel 0) and INT1 demands DMA1 (Channel 1). If the interrupts are configured in edge mode, a single byte transfer is accomplished for every request. Interrupts also result (INT0 and INT1) after every byte transfer (if enabled). If the interrupts are configured in level mode, the DMA transfer continues until the request goes inactive or BCR = 0. In either case, a DMA interrupt is generated (if enabled) when BCR = 0. The GO bit must be set for the transfer to begin.

EXTERNAL MEMORY DMA

When transferring data to or from external memory via DMA, the HOLD (HLD) and HOLD-ACKNOWLEDGE (HLDA) signals are used for handshaking. The HOLD and HOLD-ACKNOWLEDGE are active low signals which arbitrate control of the local bus. The UPI-452 can be used in a system where multi-masters are connected to a single parallel Address/Data bus. The HLD/HLDA signals are used to share resources (memory, peripherals, etc.) among all the processors on the local bus. The UPI-452 can be configured in any of three different External Memory Modes controlled by bits 5 and 6 (REQ & ARB) in the PCON SFR (Table 5). Each mode is described below:

REQUESTER MODE: In this mode, the UPI-452 is not the bus master, but must request the bus from another device. The UPI-452 configures port pin P1.5 as a HLD output and pin P1.6 as a HLDA input. The UPI-452 issues a HLD signal when it needs external access for a DMA channel. It uses the local bus after receiving the HLDA signal from the bus master, and will not release the bus until its DMA operation is complete.

ARBITER MODE: In this mode, the UPI-452 is the bus master. It configures port pin P1.5 as HLD input and pin P1.6 as HLDA output. When a device asserts the HLD signal to use the local bus, the UPI-452 asserts the HLDA signal after current instruction execution is complete. If the UPI-452 needs an external access via a DMA channel, it waits until the requester releases the bus, HLD goes inactive.

DISABLE MODE: When external program memory is accessed by an instruction or by program counter overflow beyond the internal ROM address or external data memory is accessed by MOVX instructions, it is a local memory access and the HLD/HLDA logic is not initiated. When a DMA channel attempts data transfer to/from the external data memory, the HLD/HLDA logic is initiated as described below. DMA transfers from the internal memory space to the internal memory space does not initiate the HLD/HLDA logic.

The balance of the PCON SFR bits are described in the "80C51 Register Description: Power Control SFR" section below.

Latency

When the GO bit is set, the UPI-452 finishes the current instruction before starting the DMA operation. Thus the maximum latency is 3.5 microseconds (at 14 MHz).

DMA Interrupt Vectors

Each DMA channel has a unique vectored interrupt associated with it. There are two vectored interrupts associated with the two DMA channels. The DMA interrupts are enabled and priorities set via the Interrupt Enable and Priority SFR (see "Interrupts" section). The interrupt priority scheme is similar to the scheme in 80C51.



Table 5. DMA MODE CONTROL - PCON SFR

Symbolic Address

PCON



(MSB)

(LSB)

*Defined as per MLS-51 Data Sheet
Reset Status: 00H

Physical Address

87H

Definition:

ARB	REQ	
0	0	HLD/HLDA logic is disabled. The UPI-452 is in the Requester Mode. The UPI-452 is in the Arbiter Mode. Invalid
0	1	
1	0	
1	1	

When a DMA operation is complete (BCR decrements to zero), the DONE flag in the respective DCON (DCON0 or DCON1) SFR is set. If the DMA interrupt is enabled, the DONE flag is reset automatically upon vectoring to the interrupt routine.

Interrupts When DMA is Active

If a Burst Mode DMA transfer is in progress, the interrupts are not serviced until the DMA transfer is complete. This is also true for level activated External Demand DMA transfers. During Alternate Cycle DMA transfers, however, the interrupts are serviced at the end of the DMA cycle. After that, DMA cycles and instruction execution cycles occur alternately. In the case of edge activated External Demand Mode DMA transfers, the interrupt is serviced at the end of DMA transfer of that single byte.

DMA Arbitration

Only one of the two DMA channels is active at a time, except when both are configured in the Alternate Cycle mode. In this case, the DMA cycles and Instruction Execution cycles occur in the following order:

1. DMA Cycle 0.
2. Instruction execution.
3. DMA Cycle 1.
4. Instruction execution.

DMA0 has priority over DMA1 during simultaneous activation of the two DMA channels. If one DMA channel is active, the other DMA channel, if activated, waits until the first one is complete.

If DMA0 is already in the Alternate Cycle mode and DMA1 is activated in Alternate Cycle Mode, it will take two instruction cycles before DMA1 is activated (due to the priority of DMA0). Once DMA1 becomes active, the execution will follow the normal sequence.

If DMA0 is already in the Alternate Cycle mode and DMA1 is activated in Burst Mode, the DMA1 Burst transfer will follow the DMA0 Alternate Cycle transfer (after the completion of the next instruction).

If the UPI-452 (as a Requester) asserts a HLD signal to request a DMA transfer (see "External Memory DMA") and its other DMA Channel requests a transfer before the HLDA signal is received, the channel having higher priority is activated first. A Burst Mode transfer on channel 0 can not be interrupted since DMA0 has the highest priority. A Demand Mode transfer on channel 0 is the only type of activity that can interrupt a block transfer on DMA1.

If, while executing a DMA transfer, the Arbiter receives a HLD signal, and then before it can acknowledge, its other DMA Channel requests a transfer, it then completes the second DMA transfer before sending the HLDA signal to release the bus to the HLD request.

DMA transfers may be held off under the following conditions:

1. A write to any of the DMA registers inhibits the DMA for one instruction cycle.

NOTE:

An instruction cycle may be executed in 1, 2 or 4 machine cycles dependent on the instruction being executed. DMA transfers are only executed after the completion of an instruction cycle never between machine cycles of a single instruction cycle. Similarly instruction cycles are only executed upon completion of a DMA transfer whether it be a one machine cycle transfer or two machine cycles (for ext. to ext. memory transfers).

2. A single machine cycle DMA register read operation (i.e. MOV A, DCON0) will inhibit the DMA for one instruction cycle. However a two cycle DMA register read operation will not inhibit the DMA (i.e. MOV P1, DCON0).

If the HOLD/HOLD Acknowledge logic is enabled in requestor mode the hold request will go active once the go bit has been set (for burst mode) and once the demand flag is set (for demand mode) regardless of whether the DMA is held off by one of the above conditions.

The DMA Transfer waveforms are in Figures 8-11.

T-52-33-15

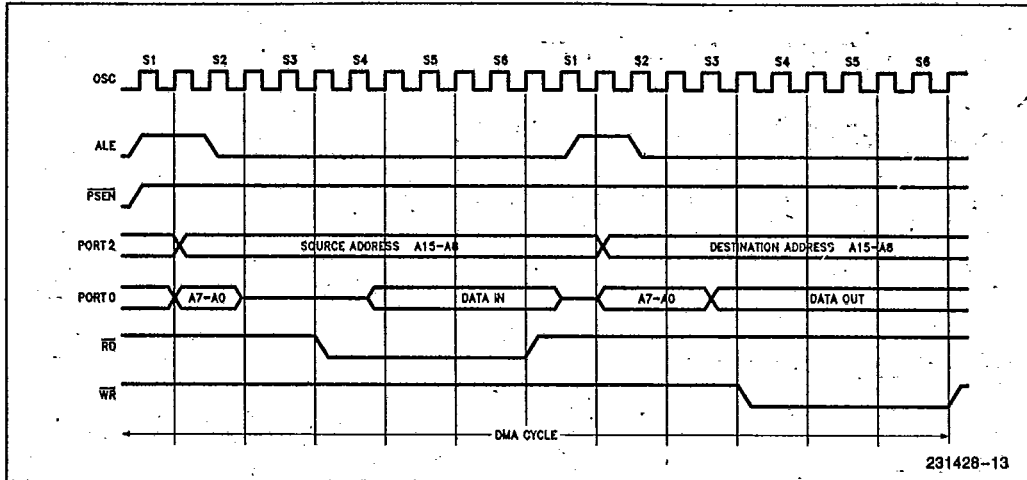

231428-13

Figure 8. DMA Transfer from External Memory to External Memory

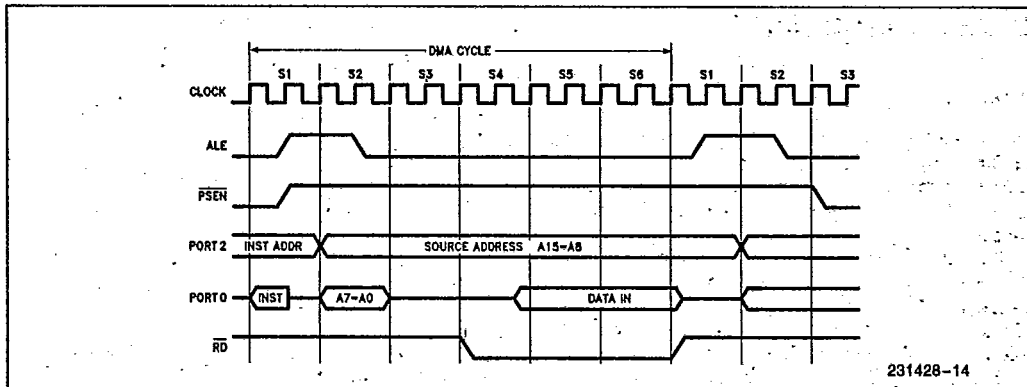

231428-14

Figure 9. DMA Transfer from External Memory to Internal Memory

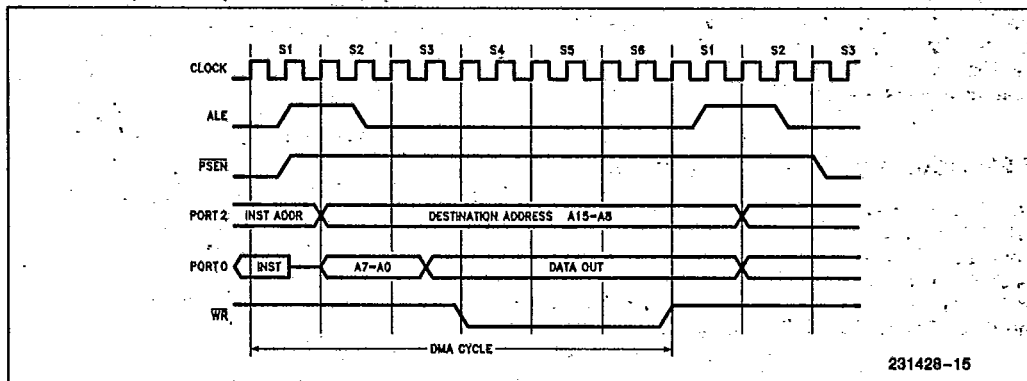

231428-15

Figure 10. DMA Transfer from Internal Memory to External Memory

6

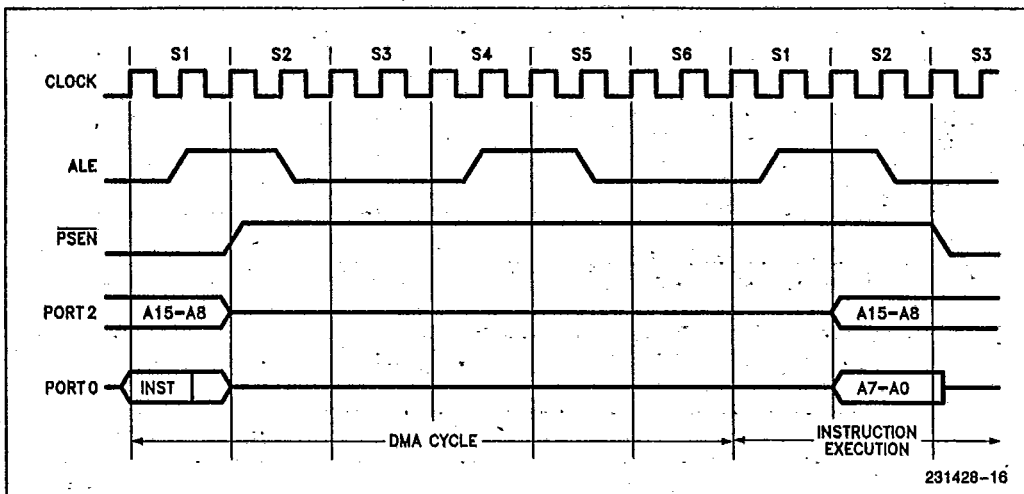

Figure 11. DMA Transfer from Internal Memory to Internal Memory

INTERNAL INTERRUPTS

Overview

The UPI-452 provides a total of eight interrupt sources (Table 6). Their operation is the same as in the 80C51, with the addition of three new interrupt sources for the UPI-452 FIFO and DMA features. These added interrupts have their enable and priority bits in the Interrupt Enable and Priority (IEP) SFR. The IEP SFR is in addition to the 80C51 Interrupt Enable (IE) and Interrupt Priority (IP) SFRs. The added interrupt sources are also globally enabled or disabled by the EA bit in the Interrupt Enable SFR. Table 6 lists the eight interrupt sources in order of priority. Table 7 lists the eight interrupt sources and their respective address vector location in program memory. (DMA Interrupts are discussed in the "General Purpose DMA Channels" section. Additional interrupt information for Timer/Counter, Serial Channel, External Interrupt may be found in the Microcontroller Handbook for the 80C51.)

FIFO Module Interrupts to Internal CPU

The FIFO module generates interrupts to the internal CPU whenever the FIFO requests service or when a Data Stream Command is in the COMMAND IN SFR. The Input FIFO will request service whenever it becomes full or not empty depending on bit 1 of the Slave Control SFR (IFRS). Similarly, the Output

Table 6. Interrupt Priority
Interrupt Source Priority Level
(highest)

External Interrupt 0	0
Internal Timer/Counter 0	1
DMA Channel 0 Request	2
External Interrupt 1	3
DMA Channel 1 Request	4
Internal Timer/Counter 1	5
FIFO - Slave Bus Interface	6
Serial Channel	7
	(lowest)

Table 7. Interrupt Vector Addresses
Interrupt Source Starting Address

External Interrupt 0	3 (003H)
Internal Timer/Counter 0	11 (00BH)
External Interrupt 1	19 (013H)
Internal Timer/Counter 1	27 (01BH)
Serial Channel	35 (023H)
FIFO - Slave Bus Interface	43 (02BH)
DMA Channel 0 Request	51 (033H)
DMA Channel 1 Request	59 (03BH)

FIFO requests service when it becomes empty or not full as determined by bit 0 of the Slave Control SFR (OFRS). Request for Service interrupts are generated only if enabled by the internal CPU via the Interrupt Enable SFR, and the Slave Control Register.



A Data Stream Command Interrupt is generated whenever there is a Data Stream Command in the COMMAND IN SFR. The interrupt is generated to ensure that the internal interrupt is recognized before another instruction is executed.

Immediate Command Interrupts

- a. An Immediate Command IN Interrupt is generated, if enabled, to the internal CPU when the Host has written to the Immediate Command IN (IMIN) SFR. The write operation clears the Slave Status SFR bit (SSTAT SST2) and sets the Host Status SFR bit (HSTAT HST2) to indicate that a byte is present in the Immediate Command IN SFR. When the internal CPU reads the Immediate Command IN (IMIN) SFR the Slave Status SFR status bit is set, and the Host Status SFR status bit is cleared indicating the IMIN SFR is empty. Clearing the Host Status SFR bit will cause a Request For Service (INTRQ) interrupt, if enabled, to signal the Host that the IMIN SFR is empty. (See Figure 7a, Immediate Command IN Flowchart.)
- b. An Immediate Command OUT Interrupt is generated, if enabled, to the internal CPU when the Host has read the Immediate Command OUT SFR. The Host read causes the Slave Status

Immediate Command OUT bit (SSTAT SST6) to be set and the corresponding Host Status bit (HSTAT HST6) to be cleared indicating the SFR is empty. When the internal CPU writes to the Immediate Command OUT SFR, the Host Status bit is set and Slave Status bit is cleared to indicate the SFR is full. (See Figure 7b, Immediate Command OUT Flowchart.)

NOTE:

Immediate Command IN and OUT interrupts are actually specific FIFO-Slave Interface interrupts to the internal CPU.

One instruction from the main program is executed between two consecutive interrupt service routines as in the 80C51. However, if the second interrupt service routine is due to a Data Stream Command Interrupt, the main program instruction is not executed (to prevent misreading of invalid data).

Interrupt Enabling and Priority

Each of the three interrupt special function registers (IE, IP and IEP) is listed below with its corresponding bit definitions.

Interrupt Enable SFR (IE)

Symbolic
Address

Physical
Address

IE	EA	—	—	ES	ET1	EX1	ET0	EX0	0A8H
	(MSB)							(LSB)	

Symbol	Position	Function
EA	IE.7	Enables all interrupts. If EA = 0, no interrupt will be acknowledged. If EA = 1, each interrupt source is individually enabled or disabled by setting or clearing its enable bit.
—	IE.6	(reserved)
—	IE.5	(reserved)
ES	IE.4	Serial Channel Interrupt enable
ET1	IE.3	Internal Timer/Counter 1 Overflow Interrupt
EX1	IE.2	External Interrupt Request 1.
ET0	IE.1	Internal Timer/Counter 0 Overflow Interrupt
EX0	IE.0	External Interrupt Request 0.



Interrupt Priority SFR (IP)

A priority level of 0 or 1 may be assigned to each interrupt source, with 1 being higher priority level, through the IP and the IEP (Interrupt Enable and Priority) SFR. A priority level of 1 interrupt can interrupt a priority level 0 service routine to allow nesting of interrupts.

Symbolic
Address

Physical
Address

IP

—	—	—	PS	PT1	PX1	PT0	PX0
---	---	---	----	-----	-----	-----	-----

 0B8H

(MSB)

(LSB)

Symbol	Position	Function	Priority Within A Level
—	IP.7	(reserved)	(lowest)
—	IP.6	(reserved)	—
—	IP.5	(reserved)	—
PS	IP.4	Local Serial Channel	0.7
PT1	IP.3	Internal Timer/Counter 1	0.5
PX1	IP.2	External Interrupt Request 1	0.3
PT0	IP.1	Internal Timer/Counter 0	0.1
PX0	IP.0	External Interrupt Request 0	0.0
			(highest)

Interrupt Enable and Priority SFR (IEP)

The Interrupt Enable and Priority Register establishes the enabling and priority of those resources not covered in the Interrupt Enable and Interrupt Priority SFRs.

Symbolic
Address

Physical
Address

IEP

—	—	PFIFO	EDMA0	EDMA1	PDMA0	PDMA1	EFIFO
---	---	-------	-------	-------	-------	-------	-------

 0F8H

(MSB)

(LSB)

Symbol	Position	Function	Priority Within a Level
—	IEP.7	(reserved)	
—	IEP.6	(reserved)	
PFIFO	IEP.5	FIFO Slave Bus Interface Interrupt Priority	0.6
EDMA0	IEP.4	DMA Channel 0 Interrupt Enable	
EDMA1	IEP.3	DMA Channel 1 Interrupt Enable	
PDMA0	IEP.2	DMA Channel 0 Priority	0.2
PDMA1	IEP.1	DMA Channel 1 Priority	0.4
EFIFO	IEP.0	FIFO Slave Bus Interface Interrupt Enable	



FIFO-EXTERNAL HOST INTERFACE FIFO DMA FREEZE MODE

Overview

During FIFO DMA Freeze Mode the internal CPU can reconfigure the FIFO interface. FIFO DMA Freeze Mode is provided to prevent the Host from accessing the FIFO during a reconfiguration sequence. The internal CPU invokes FIFO DMA Freeze Mode by clearing bit 3 of the Slave Control SFR (SC3). INTRQ becomes active whenever FIFO DMA Freeze Mode is invoked to indicate the freeze status. The interrupt can only be deactivated by the Host reading the Host Status SFR.

During FIFO DMA Freeze Mode only two operations are possible by the Host to the UPI-452 slave, the balance are disabled, as shown in Table 8. The internal DMA is disabled during FIFO DMA Freeze Mode, and the internal CPU has write access to all of the FIFO control SFRs (Table 9).

Initialization

At power on reset the FIFO Host interface is automatically frozen. The Slave Control Enable FIFO DMA Freeze Mode bit defaults to FIFO DMA Freeze Mode (SLCON FRZ=0). Below is a list of the FIFO

Special Function Registers and their default power on reset values;

SFR Name	Label	Value
Channel Boundary Pointer	CBP	40H / 64D
Output Channel Read Pointers	ORPR	40H / 64D
Output Channel Write Pointers	OWPR	40H / 64D
Input Channel Read Pointers	IRPR	00H / 00D
Input Channel Write Pointers	IWPR	00H / 00D
Input Threshold	ITHR	80H / 128D
Output Threshold	OTHR	01H / 1D

The Input and Output FIFO channels can be reconfigured by programming any of these SFRs while the UPI-452 is in the Freeze Mode. The Host is notified when the Freeze Mode is active by a "1" in HST1 of the Host Status Register (HSTAT). The Host should interrogate HST1 to determine the status of the FIFO interface following reset before attempting to read from or write to the UPI-452 FIFO buffer.

NOTE:

During the initialization sequence of the UPI-452 FIFO SFRs, the OTHR should be changed from the default setting of 1 to a value between 2 and [(80H-CBP)-1]. Please refer to the section on Input and Output FIFO threshold SFRs for further information.

Table 8. Slave Bus Interface Status During FIFO DMA Freeze Mode

Interface Pins; DACK	\overline{CS}	A2	A1	A0	READ	WRITE	Operation In Normal Mode	Status In FIFO DMA Freeze Mode
1	0	0	1	0	0	1	Read Host Status SFR	Operational
1	0	0	1	1	0	1	Read Host Control SFR	Operational
1	0	0	1	1	1	0	Write Host Control SFR	Disabled
1	0	0	0	0	0	1	Data or DMA Data from Output Channel	Disabled
1	0	0	0	0	1	0	Data or DMA Data to Input Channel	Disabled
1	0	0	0	1	0	1	Data Stream Command from Output Channel	Disabled
1	0	0	0	1	1	0	Data Stream Command to Input Channel	Disabled
1	0	1	0	0	0	1	Read Immediate Command Out from Output Channel	Disabled
1	0	1	0	0	1	0	Write Immediate Command In to Input Channel	Disabled
0	X	X	X	X	0	1	DMA Data from Output Channel	Disabled
0	X	X	X	X	1	0	DMA Data to Input Channel	Disabled



The UPI-452 can also be programmed to interrupt the Host following power on reset in order to indicate to the Host that FIFO DMA Freeze Mode is in progress. This is done by enabling the INTRQ interrupt output pin via the MODE SFR (MD4) before the Slave Control SFR Enable FIFO DMA Freeze Mode bit is set to Normal Mode. At power on reset the Mode SFR is forced to zero. This disables all interrupt and DMA output pins (INTRQ, DRQIN/INTRQIN and DRQOUT/INTRQOUT). Because the Host Status SFR FIFO DMA Freeze Mode In Progress bit is set, a Request For Service, INTRQ, interrupt is pending until the Host Status SFR is read. This is because the FIFO DMA Freeze Mode interrupt is always enabled. If the Slave Control FIFO DMA Freeze Mode bit (SLCON FRZ) is set to Normal Mode before the MODE SFR INTRQ bit is enabled, the INTRQ output will not go active when the MODE SFR INTRQ bit is enabled if the Host Status SFR has been read.

The default values for the FIFO and Slave Interface represents minimum UPI-452 internal initialization. No specific Special Function Register initialization is required to begin operation of the FIFO Slave Interface. The last initialization instruction must always set the UPI-452 to Normal Mode. This causes the UPI-452 to exit FIFO DMA Freeze Mode and enables Host read/write access of the FIFO.

Following reset, either hardware (via the RST pin) or software (via HCON SFR bit HC3) the UPI-452 requires 2 internal machine cycles (24 TCLCL) to update all internal registers.

Invoking FIFO DMA Freeze Mode During Normal Operation

When the UPI-452 is in normal operation, FIFO DMA Freeze Mode should not be arbitrarily invoked by clearing SC3 (SC3=0) because the external Host runs asynchronously to the internal CPU. Invoking

FIFO DMA Freeze Mode without first stopping the external Host from accessing the UPI-452 will not guarantee a clean break with the external Host.

The proper way to invoke FIFO DMA Freeze Mode is by issuing an Immediate Command to the external host indicating that FIFO DMA Freeze Mode will be invoked. Upon receiving the Immediate Command, the external Host should complete servicing all pending interrupts and DMA requests, then send an Immediate Command back to the UPI-452 acknowledging the FIFO DMA Freeze Mode request. After issuing the first Immediate Command, the internal CPU should not perform any action on the FIFO until FIFO DMA Freeze Mode is invoked.

If FIFO DMA Freeze Mode is invoked without stopping the Host during Host transfers, only the last two bytes of data written into or read from the FIFO will be valid. The timing diagram for disabling the FIFO module to the external Host interface is illustrated in Figure 12. Due to this synchronization sequence, the UPI-452 might not go into FIFO DMA Freeze Mode immediately after SC3 is cleared. A special bit in the Slave Status Register (SST5) is provided to indicate the status of the FIFO DMA Freeze Mode. The FIFO DMA Freeze Mode operations described in this section are only valid after SST5 is cleared.

As FIFO DMA Freeze Mode is invoked, the DRQIN or DRQOUT will be deactivated (stopping the transferring of data), bit 1 of the Host Status SFR will be set (HST1=1), and SST5 will be cleared (SST5=0) to indicate to the external Host and internal CPU that the slave interface has been frozen. After the freeze becomes effective, any attempt by the external Host to access the FIFO will cause the overrun and underrun bits to be activated (bits HST7 (for reads) or HST3 (for writes)). These two bits, HST3 and HST7, will be set (deactivated) after the Host Status SFR has been read. If INTRQ is used to request service, the FIFO interface is frozen upon completion of any Host read or write operation in progress.

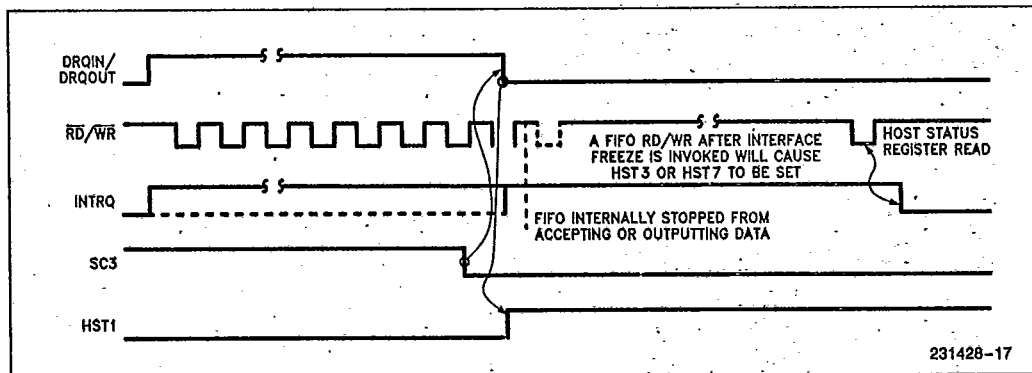

231428-17

Figure 12. Disabling FIFO to Host Slave Interface Timing Diagram
6-104



External Host writing to the Immediate Command In SFR and the Host Control SFR is also inhibited when the slave bus interface is frozen. Writing to these two registers after FIFO DMA Freeze Mode is invoked will also cause HST3 (overflow) to be activated (HST3=0). Similarly, reading the Immediate Command Out Register by the external Host is disabled during FIFO DMA Freeze Mode, and any attempt to do so will cause the clearing (deactivating, "0") of HST7 bit (underrun).

After the slave bus interface is frozen, the internal CPU can perform the following operations on the FIFO Special Function Registers (these operations are allowed only during FIFO DMA Freeze Mode).

- | | |
|----------------------------|---|
| For FIFO Reconfiguration | 1. Changing the Channel Boundary Pointer SFR. |
| | 2. Changing the Input and Output Threshold SFR. |
| To Enhance the Testability | 3. Writing to the read and write pointers of the input and Output FIFO's. |
| | 4. Writing to and reading the Host Control SFRs. |
| | 5. Controlling some bits of Host and Slave Status SFRs. |
| | 6. Reading the Immediate Command Out SFR and Writing to the Immediate Command In SFR. |

Description of each of these special functions are as follows:

FIFO Module SFRs During FIFO DMA Freeze Mode

Table 9 summarizes the characteristics of all the FIFO Special Function Registers during normal and FIFO DMA Freeze Modes. The registers that require special treatment in FIFO DMA Freeze Mode are: HCON, IWPR, IRPR, OWPR, ORPR, HSTAT, SSTAT, MIN & MOUT SFRs. They can be described in detail as follows:

Host Control SFR (HCON)

During normal operation, this register is written to or read by the external Host. However, in FIFO DMA Freeze Mode (i.e. SST5=0) the UPI-452 internal CPU has write access to the Host Control SFR and write operations to this SFR by the external Host will not be accepted. If the Host attempts to write to

HCON, the Input Channel error condition flag (HST3) will be cleared.

Input FIFO Pointer Registers (IRPR & IWPR)

Once the FIFO module is in FIFO DMA Freeze Mode, error flags due to overrun and underrun of the Input FIFO pointers will be disabled. Any attempt to create an overrun or underrun condition by changing the Input FIFO pointers would result in an inconsistency in performance between the status flag and the threshold counter.

To enhance the speed of the UPI-452, read operations on the input FIFO will look ahead by two bytes. Hence, every time the IRPR is changed during FIFO DMA Freeze Mode, two NOPs need to be executed so that the two byte pipeline can be updated with the new data bytes pointed to by the new IRPR. The Threshold Counter SFR also needs to change by the same number of bytes as the IRPR (Increase Threshold Counter if IRPR goes forward or decrease if IRPR goes backward). This will ensure that future interrupts will still be generated only after a threshold number of bytes are available. (See "Input and Output FIFO Threshold SFR" section below.)

In FIFO DMA Freeze Mode, the internal CPU can also change the content of IWPR, and each change of IWPR also requires an update of the Threshold Counter SFR.

Normally, the internal CPU cannot write into the input FIFO. It can, however, during FIFO DMA Freeze Mode by first reconfiguring the FIFO as an Output FIFO (Refer to "Input and Output FIFO Threshold SFR" section below). Changing the IRPR to be equal to IWPR generates an empty condition while changing IWPR to be equal to IRPR generates a full condition. The order in which the pointers are written determines whether a full or empty condition is generated.

Output FIFO Pointer SFR (ORPR and OWPR)

In FIFO DMA Freeze Mode the contents of OWPR can be changed by the internal CPU, but each change of OWPR or ORPR requires the Threshold Counter SFR to be updated as described in the next section. A NOP must be executed whenever a new value is written into ORPR, as just described for changes to IRPR. As before, changing ORPR to be equal to OWPR will generate an empty condition, Output FIFO overrun or underrun condition cannot be generated though. The FIFO pointers should not be set to a value outside of its range.



Table 9. FIFO SFR's Characteristics During FIFO DMA Freeze Mode

Label	Name	Normal Operation (SST5 = 1)	FIFO DMA Freeze Mode Operation (SST5 = 0)
HCON	Host Control	Not Accessible	Read & Write
HSTAT	Host Status	Read Only	Read & Write 4
SLCON	Slave Control	Read & Write	Read & Write
SSTAT	Slave Status	Read Only	Read & Write 4
IEP	Interrupt Enable & Priority	Read & Write	Read & Write
MODE	Mode Register	Read & Write	Read & Write
IWPR	Input FIFO Write Pointer	Read Only	Read & Write 5
IRPR	Input FIFO Read Pointer	Read Only	Read & Write 1, 5
OWPR	Output FIFO Write Pointer	Read Only	Read & Write 6
ORPR	Output FIFO Read Pointer	Read Only	Read & Write 2, 6
CBP	Channel Boundary Pointer	Read Only	Read & Write 3
IMIN	Immediate Command In	Read Only	Read & Write
IMOUT	Immediate Command Out	Read & Write	Read & Write
FIN	FIFO IN	Read Only	Read Only
CIN	COMMAND IN	Read Only	Read Only
FOUT	FIFO OUT	Read & Write	Read & Write
COUT	COMMAND OUT	Read & Write	Read & Write
ITHR	Input FIFO Threshold	Read Only	Read & Write
OTHR	Output FIFO Threshold	Read Only	Read & Write

NOTES:

1. Writing of IRPR will automatically cause the FIFO IN SFR to load the contents of the Input FIFO from that location.
2. Writing to ORPR will automatically cause the IOBL SFR to load the contents of the Output FIFO at that ORPR address.
3. Writing to the CBP SFR will cause automatic reset of the four pointers of the Input and Output FIFO channels.
4. The Internal CPU cannot directly change the status of these registers. However, by changing the status of the FIFO channels, the internal CPU can indirectly change the contents of the status registers.
5. Changing the Input FIFO Read/Write Pointers also requires that a consistent update of the Input FIFO Threshold Counter SFR.
6. Changing the Output FIFO Read/Write Pointers also requires that a consistent update of the Output FIFO Threshold Counter SFR.



Input and Output FIFO Threshold SFR (ITHR & OTHR)

The Input and Output FIFO Threshold SFRs are also programmable by the internal CPU during FIFO DMA Freeze Mode. For proper operation of the Threshold feature, the Threshold SFR should be changed only when the Input and Output FIFO channels are empty, since they reflect the current number of bytes available to read/write before an interrupt is generated.

Table 10 illustrates the Threshold SFRs range of values and the number of bytes to be transferred when the Request For Service Flag is activated:

Table 10. Threshold SFRs Range of Values and Number of Bytes to be Transferred

ITHR (lower seven bits)	No. of Bytes Available to be Written	OTHR (lower seven bits)	No. of Bytes Available to be Read
0	CBP	2	3
1	CBP-1	3	4
2	CBP-2	•	•
•	•	•	•
•	•	•	•
•	•	•	•
CBP-3	3	(80H-CBP)-3 (80H-CBP)-2 (80H-CBP)-1	(80H-CBP)-2 (80H-CBP)-1 (80H-CBP)

The eighth bit of the Input and Output FIFO Threshold SFR indicates the status of the service requests regardless of the freeze condition. If the eighth bit is a "1", the FIFO is requesting service from the external Host. In other words, when the Threshold SFR value goes below zero (2's complement), a service request is generated*. *The 8th bit of the ITHR SFR must be set during initialization if the Host interrupt request is desired immediately upon leaving Freeze Mode. Normally the ITHR SFR is decremented after each external Host write to the Input FIFO and incremented after each internal CPU read of the Input FIFO. The OTHR SFR is decremented by internal CPU writes and incremented by external Host reads. Thus if the pointers are moved when the FIFO's are not empty, these relationships can be used to calculate the offset for the Threshold SFRs. It is best to change the Threshold SFRs only when the FIFO's are empty to avoid this complication. The threshold registers should also be updated after the pointers have been manipulated.

NOTE:

The ITHR should only be programmed in the range from 0 to (CBP-3). An ITHR value of (CBP-2) could result in a failure to set the Input FIFO service request signal after the Input FIFO has been emptied.

Correspondingly, the OTHR should be programmed in the range from 2 to ((80H-CBP)-1). An OTHR value of 1 could result in a failure to set the Output FIFO service request after subsequent writes by the UPI-452 have filled the Output FIFO.

NOTE:

When programming the ITHR SFR, the eighth bit should be set to 1 (OR'd with 80H). This causes HSTAT SFR HST0 = 0, Input FIFO Request For Service. If ITHR bit 7 = 0 then HSTAT HST0 = 1, Input FIFO Does Not Request Service, and no interrupt will be generated.

Host Status SFR (HSTAT)

When in FIFO DMA Freeze Mode, some bits in the Host Status SFR are forced high and will not reflect the new status until the system returns to normal operation. The definition of the register in FIFO DMA Freeze Mode is as follows:

NOTE:

The internal CPU reads this shadow latch value when reading the Host Status SFR. The shadow latch will keep the information for these bits so normal operation can be resumed with the right status. The following bits are set (= 1) when FIFO DMA Freeze Mode is invoked;

HST7 Output FIFO Error Condition Flag

1 = No error.

0 = An invalid read has been done on the output FIFO or the Immediate Command Out Register by the host CPU.

NOTE:

The normal underrun error condition status is disabled. If an Immediate Command Out (IMOUT) SFR read is attempted during FIFO DMA Freeze Mode, the contents of the IMOUT SFR is output on the Data Buffer and the error status is cleared (= 0).

HST6 Immediate Command Out SFR Status

During normal operation, this bit is cleared (= 0) when the IMOUT SFR is written by the UPI-452 internal CPU and set (= 1) when the IMOUT SFR is read by the external Host. Once the host-slave interface is frozen (i.e. SST5 = 0), this bit will be read as a 1 by the host CPU. A shadow latch will keep the information for this bit so normal operation can be resumed with the correct status.

Shadow latch:

1 = Internal CPU reads the IMOUT SFR

0 = Internal CPU writes to the IMOUT SFR

**HST5 Data Stream Command at Output FIFO**

This bit is forced to a "1" during FIFO DMA Freeze Mode to prevent the external host CPU from trying to read the DSC. Once normal operation is resumed, HST5 will reflect the Data/Command status of the current byte in the Output FIFO.

Shadow Latch (read by the internal CPU):

- 1 = No Data Stream Command (DSC)
- 0 = Data Stream Command at Output FIFO.

HST4 Output FIFO Service Request Status

When FIFO DMA Freeze Mode is invoked, this bit no longer reflects the Output FIFO Request Service Status. This bit will be forced to a "1".

HST3 Input FIFO Error Condition Flag

- 1 = No error.
- 0 = One of the following operations has been attempted by the external host and is invalid:
 - 1) Write into the Input FIFO.
 - 2) Write into the Host Control SFR
 - 3) Write into the Immediate Command In SFR

NOTE:

The normal Input FIFO overrun condition is disabled.

HST2 Immediate Command In SFR Status

This bit is normally cleared when the internal CPU reads the IMIN SFR and set when the external host CPU writes into the IMIN SFR. When the host-slave interface is frozen, reading and writing of the IMIN by the internal CPU will change the shadow latch of this bit. This bit will be read as a "1" by the external Host.

Shadow latch.

- 1 = Internal CPU writes into IMIN SFR
- 0 = Internal CPU reads the IMIN SFR

HST1 FIFO DMA Freeze Mode Status

- 1 = FIFO DMA Freeze Mode.
- 0 = Normal Operation (non-FIFO DMA Freeze Mode).

NOTE:

This bit is used to indicate to the external Host that the host-slave interface has been frozen and hence the external Host functions are now reduced as shown in Table 8.

HST0 Input FIFO Request Service Status

When slave interface is frozen this bit no longer reflects the Input FIFO Request Service Status. This bit will be forced to a "1".

Slave Status SFR (SSTAT)

The Slave Status SFR is a read-only SFR. However, once the slave interface is frozen, most of the bits of this SFR can be changed by the internal CPU by reconfiguring the FIFO and accessing the FIFO Special Function Registers.

SST7 Output FIFO Overrun Error Flag

Inoperative in FIFO DMA Freeze Mode.

SST6 Immediate Command Out SFR Status

In FIFO DMA Freeze Mode, this bit will be cleared when the internal CPU reads the Immediate Command Out SFR and set when the internal CPU writes to the Immediate Command Out Register.

SST5 FIFO-External Interface FIFO DMA Freeze Mode Status

This bit indicates to the internal CPU that FIFO DMA Freeze Mode is in progress and that it has write access to the FIFO Control, Host control and Immediate Command SFRs.

SST4 Output FIFO Request Service Status

During normal operation, this bit indicates to the internal CPU that the Output FIFO is ready for more data. The status of this bit reflects the position of the Output FIFO read and write pointers. Hence, in FIFO DMA Freeze Mode, this flag can be changed by the internal CPU indirectly as the read and write pointers change.

SST3 Input FIFO Underrun Flag

Inoperative during FIFO DMA Freeze Mode.

During normal operation, a read operation clears (=0) this bit when there are no data bytes in the Input FIFO and deactivated (=1) when the Slave Status SFR is read. In FIFO DMA Freeze Mode, this bit will not be cleared by an Input FIFO read underrun error condition, nor will it be reset by the reading of the Slave Status SFR.

SST2 Immediate Command In SFR Status

This bit is normally activated (=0) when the external host CPU writes into the Immediate Command In SFR and deactivated (=1) when it is read by the internal CPU. In FIFO DMA Freeze Mode, this bit will not be activated (=0) by the external Host's writing of the Immediate Command IN SFR since this function is disabled. However, this bit will be cleared (=0) if the internal CPU writes to the Immediate Command In SFR and it will be set (=1) if it reads from the register.

**SST1 Data Stream Command at Input FIFO Flag**

In FIFO DMA Freeze Mode, this bit operates normally. It indicates whether the next byte of data from the Input FIFO is a DSC or data byte. If it is a DSC byte, reading from the FIFO IN SFR will result in reading invalid data (FFH) and vice versa. In FIFO DMA Freeze Mode, this bit still reflects the type of data byte available from the Input FIFO.

SST0 Input FIFO Service Request Flag

During normal operation, this bit is activated (=0) when the Input FIFO contains bytes that can be read by the internal CPU and deactivated (=1) when the Input FIFO does not need any service from the internal CPU. In FIFO DMA Freeze Mode, the status of this bit should not change unless the pointers of the Input FIFO are changed. In this mode, the internal CPU can indirectly change this bit by changing the read and write pointers of the Input FIFO but cannot change it directly.

Immediate Command In/Out SFR (IMIN/IMOUT)

If FIFO DMA Freeze Mode is in progress, writing to the Immediate Command In SFR by the external host will be disabled, and any such attempt will cause HST3 to be cleared (=0). Similarly, the Immediate Command Out SFR read operation (by the host) will be disabled internally and read attempts will cause HST7 to be cleared (=0).

Internal CPU Read and Write of the FIFO During FIFO DMA Freeze Mode

In normal operation, the Input FIFO can only be read by the internal CPU and similarly, the Output FIFO can only be written by the internal CPU. During FIFO DMA Freeze Mode, the internal CPU can read the entire contents of the Input FIFO by programming the CBP SFR to 7FH, setting the IRPR SFR to zero, and then the IWPR SFR to zero. Programming the pointer registers in this order generates a FIFO full signal to the FIFO logic and enables internal CPU read operations. If the IWPR and IRPR are already zero, the write pointer should be changed to a non-zero value to clear the empty status then the pointers can be set to zero. Writing to the IRDR SFR automatically updates the look ahead registers.

In a similar manner, the internal CPU can write to all 128 bytes of the FIFO by setting the CBP SFR to zero, setting OWPR SFR to zero, and then setting

ORPR SFR to zero. This generates a FIFO empty signal and allows internal CPU write operations to all 128 bytes of the FIFO. The Threshold registers also need to be adjusted when the pointers are changed. (See "Input and Output FIFO Threshold SFR" section below.)

MEMORY ORGANIZATION

The UPI-452 has separate address spaces for Program Memory and Data Memory like the 80C51. The Program Memory can be up to 64K bytes. The lower 8K of Program Memory may reside on-chip. The Data Memory consists of 256 bytes of on-chip RAM, up to 64K bytes of off-chip RAM and a number of "SFRs" (Special Function Registers) which appear as yet another set of unique memory addresses.

Table 11a. Internal Memory Addressing

Memory Space	Addressing Method
Lower 128 Bytes of Internal RAM	Direct or Indirect
Upper 128 Bytes of Internal RAM	Indirect Only
UPI-452 SFR's	Direct Only

The 80C51 Special Function Registers are listed in Table 11a, and the additional UPI-452 SFRs are listed in Table 11b. A brief description of the 80C51 core SFRs is also provided below.

Accessing External Memory

As in the 80C51, accesses to external memory are of two types: Accesses to external Program Memory and accesses to external Data Memory.

External Program Memory is accessed under two conditions:

- 1) Whenever signal $\overline{EA} = 0$; or
- 2) Whenever the program counter (PC) contains a number that is larger than 1FFFFH.

This requires that the ROMless versions have \overline{EA} wired low to enable the lower 8K program bytes to be fetched from external memory.

External Data Memory is accessed using either the MOVX @DPTR (16 bit address) or the MOVX @Ri (8 bit address) instructions, or during external data memory transfers.



Table 11b. 80C51 Special Function Registers

Symbol	Name	Address	Contents
*ACC	Accumulator	0E0H	00H
*B	B Register	0F0H	00H
*PSW	Program Status Word	0D0H	00H
SP	Stack Pointer	81H	07H
DPTR	Data Pointer (consisting of DPH and DPL)	82H	0000H
*P0	Port 0	80H	0FFH
*P1	Port 1	90H	0FFH
*P2	Port 2	0A0H	0FFH
*P3	Port 3	0B0H	0FFH
*IP	Interrupt Priority Control	0B8H	0E0H
*IE	Interrupt Enable Control	0A8H	60H
TMOD	Timer/Counter Mode Control	89H	00H
*TCON	Timer/Counter Control	88H	00H
TH0	Timer/Counter 0 (high byte)	8CH	00H
TL0	Timer/Counter 0 (low byte)	8AH	00H
TH1	Timer/Counter 1 (high byte)	8DH	00H
TL1	Timer/Counter 1 (low byte)	8BH	00H
*SCON	Serial Control	98H	00H
SBUF	Serial Data Buff	99H	I
PCON	Power Control	87H	10H

I = Indeterminate

The SFRs marked with an asterisk (*) are both bit- and byte- addressable. The functions of the SFRs are as follows:

Table 11c. UPI-452 Additional Special Function Registers

Symbol	Name	Address	Contents
BCRL0	DMA Byte Count Low Byte/ Channel 0	0E2H	I
BCRH0	High Byte/ Channel 0	0E3H	I
BCRL1	Low Byte/ Channel 1	0F2H	I
BCRH1	Hi Byte/ Channel 1	0F3H	I
CBP	Channel Boundary Pointer	0ECH	40H
CIN	COMMAND IN	0EFH	I
COUT	COMMAND OUT DMA Destination Address	0FFH	I

Table 11c. UPI-452 Additional Special Function Registers (Continued)

Symbol	Name	Address	Contents
DARL0	Low Byte/ Channel 0	0C2H	I
DARH0	Hi Byte/ Channel 0	0C3H	I
DARL1	Low Byte/ Channel 1	0D2H	I
DARH1	Hi Byte/ Channel 1	0D3H	I
DCON0	DMA0 Control	92H	00H
DCON1	DMA1 Control	93H	00H
FIN	FIFO IN	0EEH	I
FOUT	FIFO OUT	0FEH	I
HCON	Host Control	0E7H	00H
HSTAT	Host Status	0E6H	0FBH
*IEP	Interrupt Enable and Priority	0F8H	0C0H
IMIN	Immediate Command In	0FCH	I
IMOUT	Immediate Command Out	0FDH	I
IRPR	Input Read Pointer	0EBH	00H
ITHR	Input FIFO Threshold	0F6H	80H
IWPR	Input Write Pointer	0EAH	00H
MODE	Mode Register	0F9H	8FH
ORPR	Output Read Pointer	0FAH	40H
OTHR	Output FIFO Threshold	0F7H	01H
OWPR	Output Write Threshold	0FBH	40H
*P4	Port 4 DMA Source Address	0C0H	0FFH
SARL0	Low Byte/ Channel 0	0A2H	I
SARH0	Hi Byte/ Channel 0	0A3H	I
SARL1	Low Byte/ Channel 1	0B2H	I
SARH1	Hi Byte/ Channel 1	0B3H	I
*SLCON	Slave Control	0E8H	04H
SSTAT	Slave Status	0E9H	08FH

I = Indeterminate

The SFRs marked with an asterisk (*) are both bit- and byte- addressable. The functions of the SFRs are as follows:



Miscellaneous Special Function Register Description

80C51 SFRs

ACCUMULATOR

ACC is the Accumulator SFR. The mnemonics for accumulator-specific instructions, however, refer to the accumulator simply as A.

B REGISTER

The B SFR is used during multiply and divide operations. For other instructions it can be treated as another scratch pad register.

PROGRAM STATUS WORD

The PSW SFR contains program status information as detailed in Table 12.

STACK POINTER

The Stack Pointer register is 8 bits wide. It is incremented before data is stored during PUSH and CALL executions. While the stack may reside anywhere in on-chip RAM, the Stack Pointer is initialized to 07H after a reset. This causes the stack to begin at location 08H.

DATA POINTER

The Data Pointer (DPTR) consists of a high byte (DPH) and a low byte (DPL). Its intended function is to hold a 16-bit address. It may be manipulated as a 16-bit register or as two independent 8-bit registers.

PORTS 0 TO 4

P0, P1, P2, P3 and P4 are the SFR latches of Ports 0, 1, 2, 3 and 4, respectively.

SERIAL DATA BUFFER

The Serial Data Buffer is actually two separate registers, a transmit buffer and a receive buffer register. When data is moved to SBUF, it goes to the transmit buffer where it is held for serial transmission. (Moving a byte to SBUF is what initiates the transmission.) When data is moved from SBUF, it comes from the receive buffer.

TIMER/COUNTER SFR

Register pairs (TH0, TL0), and (TH1, TL1) are the 16-bit counting registers for Timer/Counters 0 and 2.

POWER CONTROL SFR (PCON)

The PCON Register (Table 13) controls the power down and idle modes in the UPI-452, as well as providing the ability to double the Serial Channel baud rate. There are also two general purpose flag bits available to the user. Bits 5 and 6 are used to set the HOLD/HOLD Acknowledge mode (see "General Purpose DMA Channels" section), and bit 4 is not used.



Table 12. Program Status Word

Symbolic Address								Physical Address	
PSW	CY	AC	FO	RS1	RS0	OV	—	P	0D0H
	(MSB)				(LSB)				

Symbol	Position	Name
CY	PSW.7	Carry Flag
AC	PSW.6	Auxiliary Carry (For BCD operations)
FO	PSW.5	Flag 0 (user assignable)
RS1	PSW.4	Register Bank Select bit 1*
RS0	PSW.3	Register Bank Select bit 0*
OV	PSW.2	Overflow Flag
—	PSW.1	(reserved)
P	PSW.0	Parity Flag

* (RS1, RS0) enable Internal RAM register banks as follows:

RS1	RS0	Internal RAM Register Bank
0	0	Bank 0
0	1	Bank 1
1	0	Bank 2
1	1	Bank 3

Table 13. PCON Special Function Register

Symbolic Address								Physical Address	
PCON	SMOD	ARB	REQ	—	GF1	GF0	PD	IDL	087H
	(MSB)				(LSB)				

Symbol	Position	Function
SMOD	PCON7	Double Baud rate bit. When set to a 1, the baud rate is doubled when the serial port is being used in either Mode 1, 2 or 3.
ARB	PCON6	HLD/HLDA Arbiter control bit *
REQ	PCON5	HLD/HLDA Requestor control bit *
—	PCON4	(reserved)
GF1	PCON3	General-purpose flag bit
GF0	PCON2	General-purpose flag bit
PD	PCON1	Power Down bit. Setting this bit activates power down operation.
IDL	PCON0	Idle Mode bit. Setting this bit activates idle mode operation.

*See "Ext. Memory DMA" description.

NOTE:

If 1's are written to PD and IDL at the same time, PD takes precedence. The reset value of PCON is (000X0000).

**ABSOLUTE MAXIMUM RATINGS***

Ambient Temperature Under Bias 0°C to 70°C†
 Storage Temperature -65°C to +150°C
 Voltage on Any Pin to V_{SS} -0.5V to V_{CC} + 0.5V
 Voltage on V_{CC} to V_{SS} -0.5V to +6.5V
 Power Dissipation.....1.0W**

NOTICE: This is a production data sheet. The specifications are subject to change without notice.

*WARNING: Stressing the device beyond the "Absolute Maximum Ratings" may cause permanent damage. These are stress ratings only. Operation beyond the "Operating Conditions" is not recommended and extended exposure beyond the "Operating Conditions" may affect device reliability.

D.C. CHARACTERISTICS T_A = 0°C to 70°C; V_{CC} = 5V ± 10%; V_{SS} = 0V

Symbol	Parameter	Min	Max	Units	Test Conditions
V _{IL}	Input Low Voltage	-0.5	0.8	V	
V _{IH}	Input High Voltage (except XTAL1, RST)	2.0	V _{CC} + 0.5	V	
V _{IH1}	Input High Voltage (XTAL1, RST)	3.9	V _{CC} + 0.5	V	
V _{OL}	Output Low Voltage (Ports 1, 2, 3, 4)		0.45	V	I _{OL} = 1.6 mA (Note 1)
V _{OL1}	Output Low Voltage (except Ports 1, 2, 3, 4)		0.45	V	I _{OL} = 3.2 mA (Note 1)
V _{OH}	Output High Voltage (Ports 1, 2, 3, 4)	2.4		V	I _{OH} = -60 μA, V _{CC} = 5V ± 10%
		0.9 V _{CC}		V	I _{OH} = -10 μA
V _{OH1}	Output High Voltage (except Ports 1, 2, 3, 4 and Host Interface (Slave) Port)	2.4		V	I _{OH} = -400 μA, V _{CC} = 5V ± 10%
		0.9 V _{CC}		V	I _{OH} = -40 μA (Note 2)
V _{OH2}	Output High Voltage (Host Interface (Slave) Port)	2.4		V	I _{OH} = -400 μA, V _{CC} = 5V ± 10%
		V _{CC} - 0.4		V	I _{OH} = -10 μA
I _{IL}	Logical 0 Input Current (Ports 1, 2, 3, 4)		-50	μA	V _{IN} = 0.45V
I _{TL}	Logical 1 to 0 Transition Current (Ports 1, 2, 3, 4)		-650	μA	V _{IN} = 2V

D.C. CHARACTERISTICS $T_A = 0^\circ\text{C to } 70^\circ\text{C}$; $V_{CC} = 5V \pm 10\%$; $V_{SS} = 0V$ (Continued)

Symbol	Parameter	Min	Max	Units	Test Conditions
I_{LI}	Input Leakage Current (except Ports 1, 2, 3, 4)		± 10	μA	$0.45V < V_{IN} < V_{CC}$
I_{OZ}	Output Leakage Current (except Ports 1, 2, 3, 4)		± 10	μA	$0.45V < V_{OUT} < V_{CC}$
I_{CC}	Operating Current		50	mA	$V_{CC} = 5.5V$, 14 MHz (Note 4)
I_{CCI}	Idle Mode Current		25	mA	$V_{CC} = 5.5V$, 14 MHz (Note 5)
I_{PD}	Power Down Current		100	μA	$V_{CC} = 2V$ (Note 3)
RRST	Reset Pulldown Resistor	50	150	$\text{K}\Omega$	
CIO	Pin Capacitance		20	pF	1 MHz, $T_A = 25^\circ\text{C}$ (sampled, not tested on all parts)

NOTES:

1. Capacitive loading on Ports 0 and 2 may cause spurious noise pulses to be superimposed on the V_{OLS} of ALE and Ports 1 and 3. The noise is due to external bus capacitance discharging into the Port 0 and Port 2 pins when these pins make 1-to-0 transitions during bus operations. In the worst cases (capacitive loading > 100 pF), the noise pulse on the ALE line may exceed 0.8V. In such cases it may be desirable to qualify ALE with a Schmitt Trigger, or use an address latch with a Schmitt Trigger STROBE input.

2. Capacitive loading on Ports 0 and 2 may cause the V_{OH} on ALE and PSEN to momentarily fall before the 0.9 V_{CC} specification when the address bits are stabilizing.

3. Power DOWN I_{CC} is measured with all output pins disconnected; EA = Port 0 = V_{CC} ; XTAL2 N.C.; RST = V_{SS} ; DB = V_{CC} ; WR = RD = DACK = CS = A0 = A1 = A2 = V_{CC} . Power Down Mode is not supported on the 87C452P.

4. I_{CC} is measured with all output pins disconnected; XTAL1 driven with TCLCH, TCHCL = 5 ns, $V_{IL} = V_{SS} + 0.5V$, $V_{IH} = V_{CC} - 0.5V$; XTAL2 N.C.; EA = RST = Port 0 = V_{CC} ; WR = RD = DACK = CS = A0 = A1 = A2 = V_{CC} . I_{CC} would be slightly higher if a crystal oscillator is used.

5. Idle I_{CC} is measured with all output pins disconnected; XTAL1 driven with TCLCH, TCHCL = 5 ns, $V_{IL} = V_{SS} + 0.5V$, $V_{IH} = V_{CC} - 0.5V$; XTAL2 N.C.; Port 0 = V_{CC} ; EA = RST = V_{SS} ; WR = RD = DACK = CS = A0 = A1 = A2 = V_{CC} .

EXPLANATION OF THE AC SYMBOLS

Each timing symbol has 5 characters. The first character is always a 'T' (stands for time). The other characters, depending on their positions, stand for the name of a signal or the logical status of that signal. The following is a list of all the characters and what they stand for:

A: Address.

C: Clock.

D: Input data.

H: Logic level HIGH.

I: Instruction (program memory contents).

L: Logic level LOW, or ALE.

P: PSEN.

Q: Output data.

R: READ signal.

T: Time.

V: Valid.

W: WRITE signal.

X: No longer a valid logic level.

Z: Float.

EXAMPLE

TAVLL = Time for Address Valid to ALE Low.

TLLPL = Time for ALE Low to PSEN Low.



A.C. CHARACTERISTICS $T_A = 0^\circ\text{C}$ to 70°C , $V_{CC} = 5\text{V} \pm 10\%$, $V_{SS} = 0\text{V}$, Load Capacitance for Port 0, ALE, and PSEN = 100 pF, Load Capacitance for All Other Outputs = 80 pF

EXTERNAL PROGRAM AND DATA MEMORY CHARACTERISTICS

Symbol	Parameter	14 MHz Osc		Variable Oscillator		Units
		Min	Max	Min	Max	
1/TCLCL	Oscillator Frequency	3.5	14			MHz
TLHLL	ALE Pulse Width	103		2TCLCL - 40		ns
TAVLL	Address Valid to ALE Low (Note 1)	25		TCLCL - 55		ns
TLLAX	Address Hold after ALE Low	36		TCLCL - 35		ns
TLLIV	ALE Low to Valid Instr In		185		4TCLCL - 100	ns
TLLPL	ALE Low to PSEN Low	31		TCLCL - 40		ns
TPLPH	PSEN Pulse Width	169		3TCLCL - 45		ns
TPLIV	PSEN Low to Valid Instr In		110		3TCLCL - 105	ns
TPXIX	Input Instr Hold after PSEN	0		0		ns
TPXIZ	Input Instr Float after PSEN (Note 1)		57		TCLCL - 25	ns
TAVIV	Address to Valid Instr In		252		5TCLCL - 105	ns
TPLAZ	PSEN Low to Address Float		10		10	ns
TRLRH	RD Pulse Width	329		6TCLCL - 100		ns
TWLWH	WR Pulse Width	329		6TCLCL - 100		ns
TRLDV	RD Low to Valid Data In		192		5TCLCL - 165	ns
TRHDX	Data Hold after RD	0		0		ns
TRHDZ	Data Float after RD		73		2TCLCL - 70	ns
TLLDV	ALE Low to Valid Data In		422		8TCLCL - 150	ns
TAVDV	Address to Valid Data In		478		9TCLCL - 165	ns
TLLWL	ALE Low to RD or WR Low	164	264	3TCLCL - 50	3TCLCL + 50	ns
TAVWL	Address Valid to RD or WR Low	156		4TCLCL - 130		ns
TQVWX	Data Valid to WR Transition	11		TCLCL - 60		ns
TWHQX	Data Hold after WR	21		TCLCL - 50		ns
TRLAZ	RD Low to Address Float		0		0	ns
TWHLH	RD or WR High to ALE High	31	111	TCLCL - 40	TCLCL + 40	ns
TQVWH	Data Valid to WR (Setup Time)	350		7TCLCL - 150		ns

NOTE:

1. Use the value of 14 MHz specification or variable oscillator specification, whichever is greater.



EXTERNAL DATA MEMORY READ CYCLE

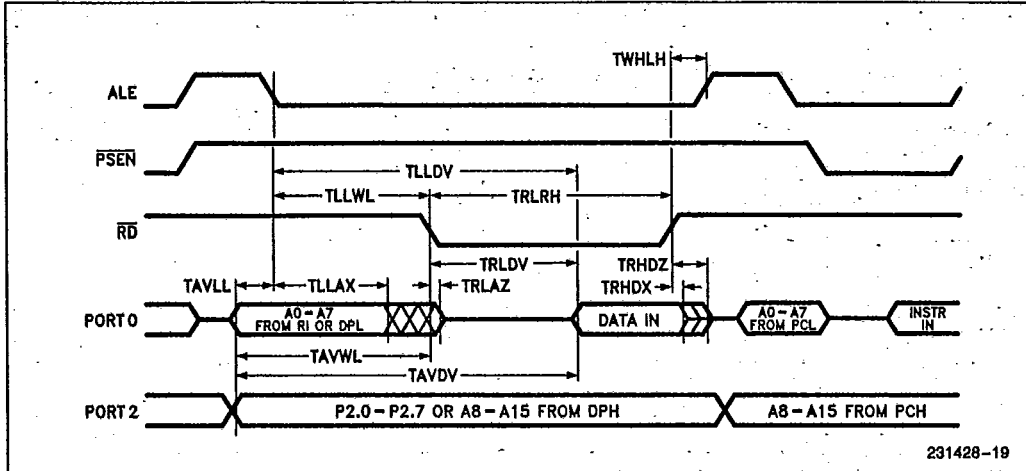

EXTERNAL PROGRAM MEMORY READ CYCLE

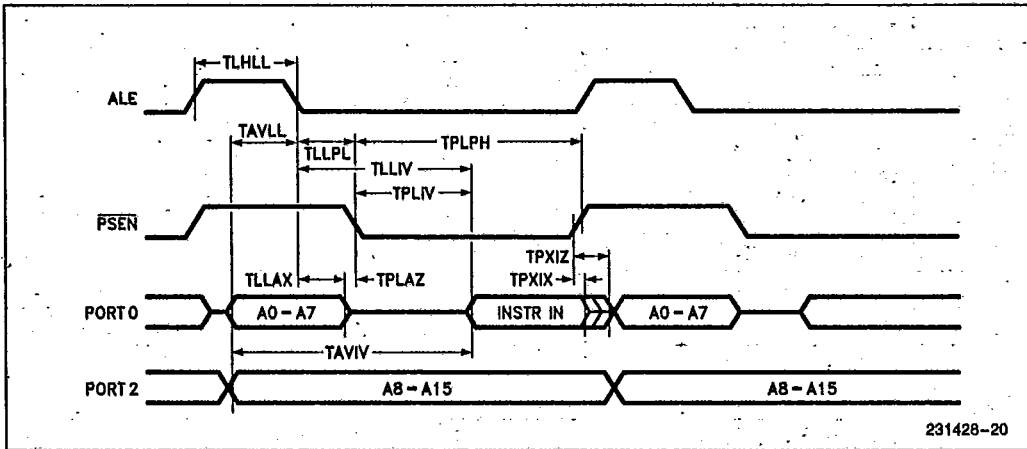



T-52-33-15

EXTERNAL DATA MEMORY WRITE CYCLE

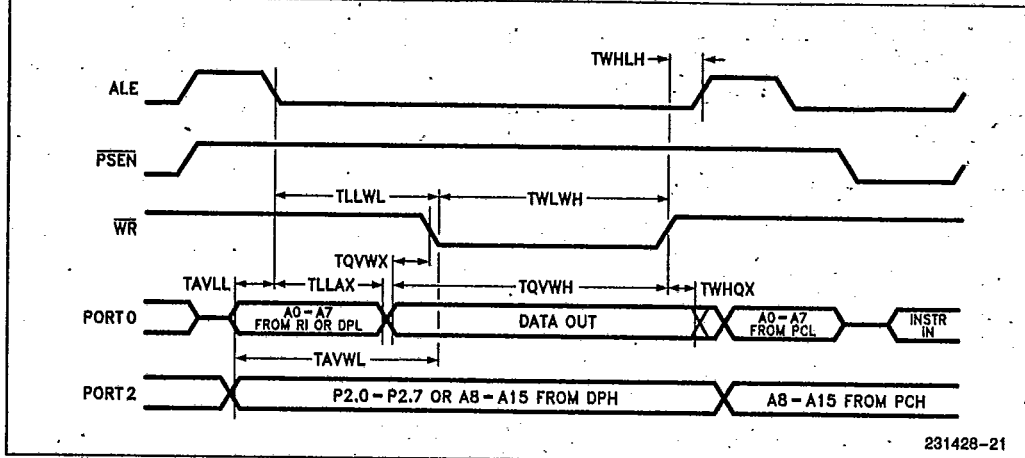

SHIFT REGISTER MODE TIMING WAVEFORMS

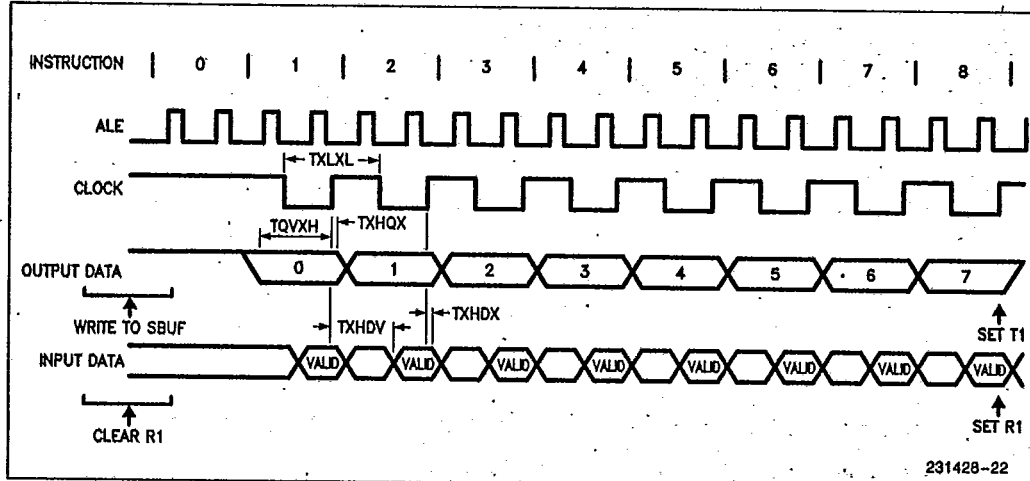



UPI-452

T-52-33-15

EXTERNAL CLOCK DRIVE

Symbol	Parameter	Min	Max	Units
1/TCLCL	Oscillator Frequency	3.5	14	MHz
TCHCX	High Time	20		ns
TCLCX	Low Time	20		ns
TCLCH	Rise Time		20	ns
TCHCL	Fall Time		20	ns

NOTE:

External clock timings are sampled, not tested on all parts.

SERIAL PORT TIMING—SHIFT REGISTER MODE

Test Conditions: $T_A = 0^\circ\text{C to } 70^\circ\text{C}$; $V_{CC} = 5\text{V} \pm 10\%$; $V_{SS} = 0\text{V}$; Load Capacitance = 80 pF

Symbol	Parameter	14 MHz Osc		Variable Oscillator		Units
		Min	Max	Min	Max	
TXLXL	Serial Port Clock Cycle Time	857		12TCLCL		ns
TQVXH	Output Data Setup to Clock Rising Edge	581		10TCLCL - 133		ns
TXHQX	Output Data Hold after Clock Rising Edge	26		2TCLCL - 117		ns
TXHDX	Input Data Hold after Clock Rising Edge	0		0		ns
TXHDV	Clock Rising Edge to Input Data Valid		581		10TCLCL - 133	ns

EXTERNAL CLOCK DRIVE WAVEFORM

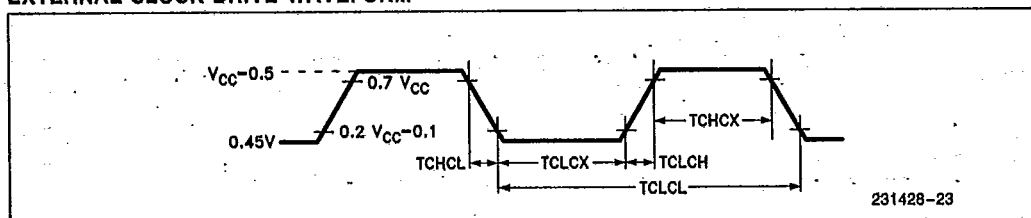

AC TESTING INPUT, OUTPUT WAVEFORMS

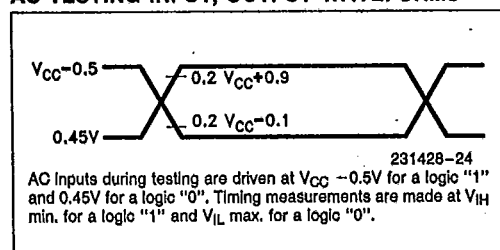

FLOAT WAVEFORMS

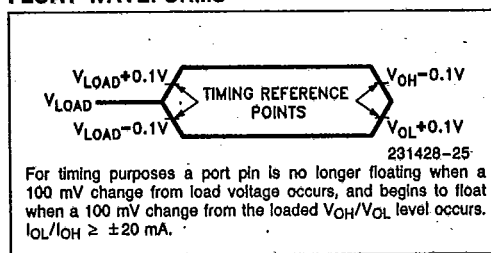



HLD/HLDA WAVEFORMS

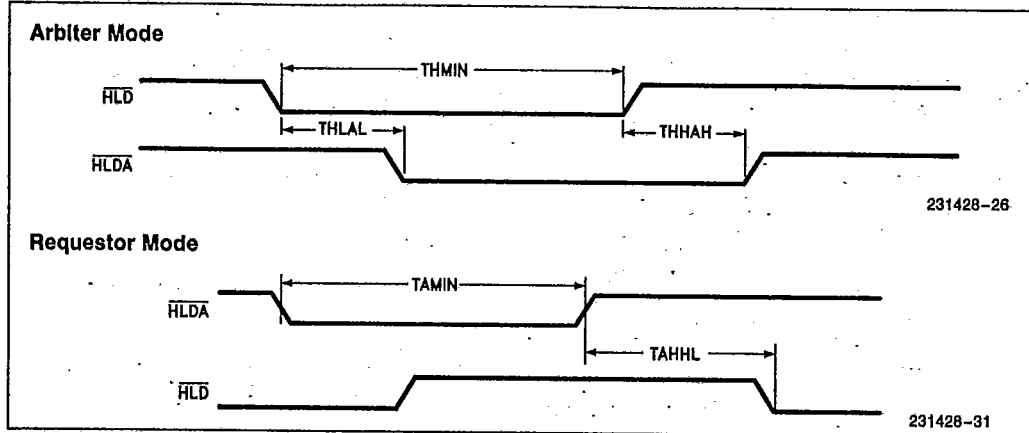

HLD/HLDA TIMINGS

Test Conditions: $T_A = 0^\circ\text{C}$ to $+70^\circ\text{C}$; $V_{CC} = 5V \pm 10\%$, $V_{SS} = 0V$; Load Capacitance = 80 pF

Symbol	Parameter	14 MHz Osc		Variable Oscillator		Units
		Min	Max	Min	Max	
THMIN	HLD Pulse Width	386		$4TCLCL + 100$		ns
THLAL	HLD to HLDA Delay if HLDA is Granted	186	672	$4TCLCL - 100$	$8TCLCL + 100$	ns
THHAH	HLD to HLDA Delay	186	672	$4TCLCL - 100$	$8TCLCL + 100$	ns
TAMIN	HLDA Pulse Width	386		$4TCLCL + 100$		ns
TAHHL	HLDA Inactive to HLD Active	186		$4TCLCL - 100$		ns



HOST PORT WAVEFORMS

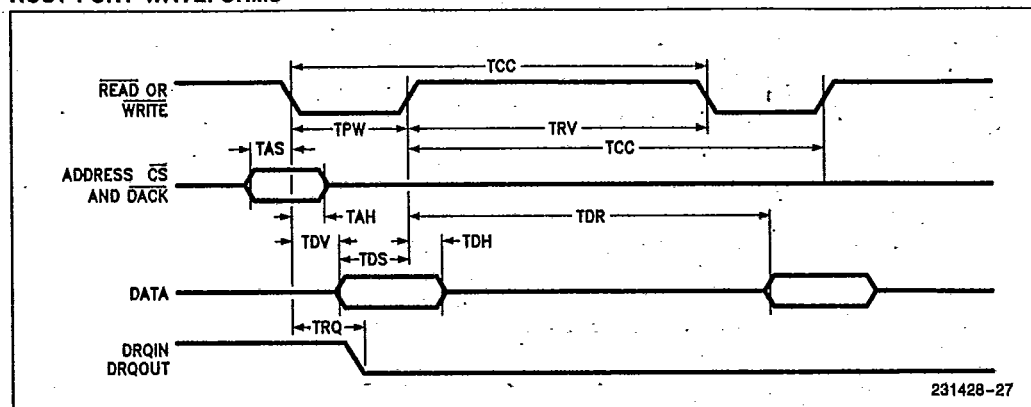

HOST PORT TIMINGS

Test Conditions: $T_A = 0^\circ\text{C to } 70^\circ\text{C}$; $V_{CC} = 5V \pm 10\%$; $V_{SS} = 0V$; Load Capacitance = 80 pF

Symbol	Parameter	14 MHz Osc		Variable Oscillator		Units
		Min	Max	Min	Max	
TCC	Cycle Time	429		6TCLCL		ns
TPW	Command Pulse Width	100		100		ns
TRV	Recovery Time	60		60		ns
TAS	Address Setup Time	5		5		ns
TAH	Address Hold Time	30		30		ns
TDS	WRITE Data Setup Time	30		30		ns
TDHW	WRITE Data Hold Time	5		5		ns
TDHR	READ Data Hold Time	5	40	5	40	ns
TDV	READ Active to Read Data Valid Delay		92		92	ns
TDR	WRITE Inactive to Read Data Valid Delay (Applies only to Host Control SFR)		343		4.8TCLCL	ns
TRQ	READ or WRITE Active to DRQIN or DRQOUT Inactive Delay		150		150	ns

**REVISION HISTORY**

DOCUMENT: UPI-452 Data Sheet

OLD REVISION NUMBER: 231428-004

NEW REVISION NUMBER: 231428-005

1. Maximum Clock Rate was changed from 16 MHz to 14 MHz. This change is reflected in all Maximum Timing specifications.
2. The proper range of values for ITHR has been changed from [0 to (CBP-2)] to [0 to (CBP-3)] to ensure proper setting of the Input FIFO request for service bit. See the following sections: INPUT FIFO CHANNEL, and INPUT AND OUTPUT FIFO THRESHOLD SFR (ITHR & OTHR).
3. The proper range of values for OTHR has been changed from [1 to ((80H-CBP)-1)] to [2 to ((80-CBP)-1)] to ensure proper setting of the Output FIFO request for service bit. See the following sections: OUTPUT FIFO CHANNEL, FIFO-EXTERNAL HOST INTERFACE FIFO DMA FREEZE MODE, and INPUT AND OUTPUT FIFO THRESHOLD SFR (ITHR & OTHR).
4. The following D.C. Characteristics were deleted from the data sheet:
 $V_{OH} = 0.75 * V_{CC} @ I_{OH} = -25 \mu A,$
 $V_{OH1} = 0.75 * V_{CC} @ I_{OH} = 150 \mu A,$
 $V_{OH2} = 3.0V @ I_{OH} = 1 mA,$ and
 $I_{CC1} = 15 mA @ V_{CC} = 5.5V (87C452P).$
See D.C. CHARACTERISTICS TABLE.
5. The parameter descriptions for THHAH and THLAL has been reversed and their maximum specification for clock rates less than 14 MHz has been changed from [4TCLC + 100 ns] to [8TCLC + 100 ns]. See HLD/HLDA TIMINGS.
6. TAMIN specification has been removed from the Arbiter Mode waveform diagram and added to the Requestor Mode waveform diagram. See HLD/HLDA WAVEFORMS.