

FEATURES

- BIDIRECTIONAL CROWBAR PROTECTION.
- BREAKDOWN VOLTAGE RANGE:
From 62 V To 270 V.
- HOLDING CURRENT = I_H
Suffix 12 = 120mA min.
Suffix 18 = 180mA min.
- PEAK PULSE CURRENT :
 $I_{PP} = 90 \text{ A}, 10/1000 \mu\text{s}.$

DESCRIPTION

The TPBxx series has been designed to protect telecommunication equipments against lightning and transient induced by AC power lines.

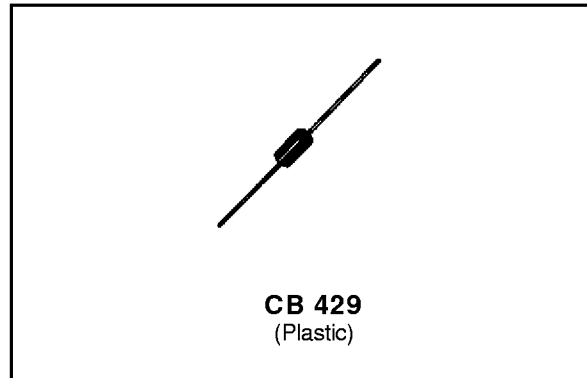

IN ACCORDANCE WITH FOLLOWING STANDARDS :

| | | | |
|-----------------|---|-----------------------|--------|
| CCITT K17 - K20 | { | 10/700 μs | 1.5 kV |
| | | 5/310 μs | 38 A |
| VDE 0433 | { | 10/700 μs | 2 kV |
| | | 5/200 μs | 50 A |
| CNET | { | 0.5/700 μs | 1.5 kV |
| | | 0.2/310 μs | 38 A |

SCHEMATIC DIAGRAM

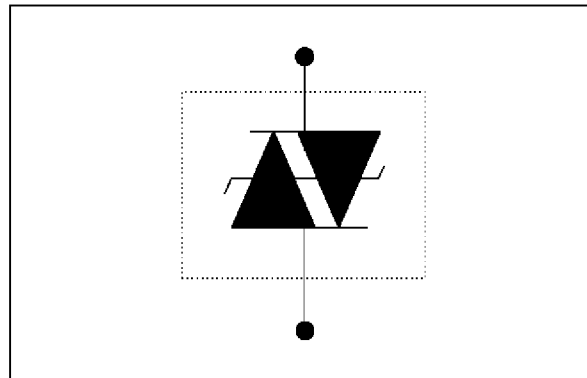

ABSOLUTE RATINGS (limiting values) ($-40^{\circ}\text{C} \leq T_{\text{amb}} \leq + 85^{\circ}\text{C}$)

| Symbol | Parameter | | Value | Unit |
|---------------------------|---|---|------------------------|--|
| P | Power dissipation on infinite heatsink | $T_{\text{amb}} = 50^{\circ}\text{C}$ | 5 | W |
| I_{PP} | Peak pulse current See note 1 | 10/1000 μs 8/20 μs | 90 150 | A |
| I_{TSM} | Non repetitive surge peak on-state current | $t_p = 20 \text{ ms}$ | 50 | A |
| di/dt | Critical rate of rise of on-state current | Non repetitive | 100 | A/ μs |
| dv/dt | Critical rate of rise of off-state voltage | 67% VBR | 5 | KV/ μs |
| T_{stg} T_j | Storage and operating junction temperature range | | - 40 to + 150 + 150 | $^{\circ}\text{C}$ $^{\circ}\text{C}$ |
| T_L | Maximum lead temperature for soldering during 10 s. | | 230 | $^{\circ}\text{C}$ |

THERMAL RESISTANCES

| Symbol | Parameter | Value | Unit |
|---------------|--|-------|------|
| $R_{th(j-l)}$ | Junction to leads. On infinite heatsink. | 20 | °C/W |
| $R_{th(j-a)}$ | Junction to ambient. On printed circuit. $L_{lead} = 10\text{ mm}$ | 75 | °C/W |

Note 1: 10/1000 μs wave form.

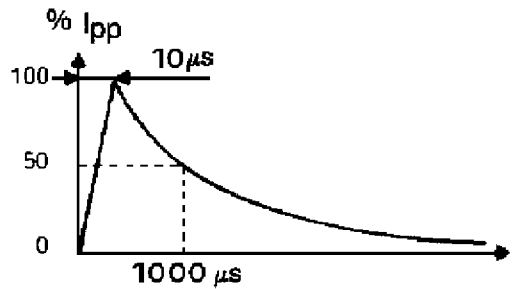

ELECTRICAL CHARACTERISTICS

| Symbol | Parameter |
|----------|--------------------|
| V_{RM} | Stand-off voltage |
| V_{BR} | Breakdown voltage |
| V_{BO} | Breakover voltage |
| I_H | Holding current |
| V_T | On-state voltage |
| I_{BO} | Breakover current |
| I_{PP} | Peak pulse current |

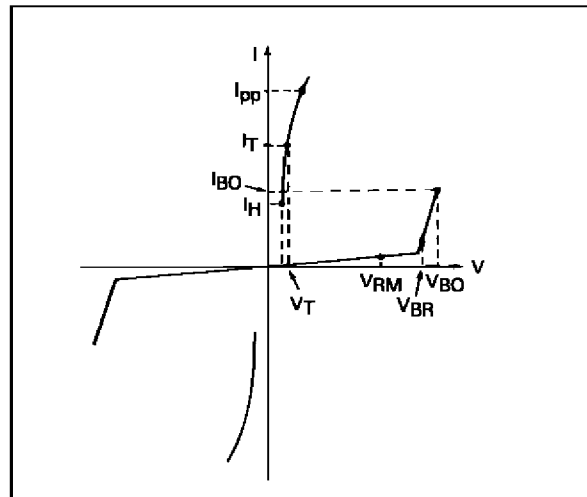

ELECTRICAL CHARACTERISTICS

| Type | I _{RM} @ V _{RM} | | V _{BR} @ I _R | | V _{BO} @ I _{BO} | | V _T | C | I _H |
|------------------------|-----------------------------------|-----|----------------------------------|----|-----------------------------------|-----|----------------|-----|--------------------------|
| | max | | min | | max | max | max | max | min |
| | μA | V | V | mA | V | mA | V | pF | note2 |
| P TPB62A - 12 or 18 | 2 | 56 | 62 | 1 | 82 | 300 | 3.5 | 300 | Suffix 12 for 120 mA. |
| TPB62B - 12 or 18 | 2 | 56 | 62 | 1 | 75 | 300 | 3.5 | 300 | |
| P TPB68A - 12 or 18 | 2 | 61 | 68 | 1 | 90 | 300 | 3.5 | 300 | |
| TPB68B - 12 or 18 | 2 | 61 | 68 | 1 | 82 | 300 | 3.5 | 300 | |
| (1) TPB75A - 12 or 18 | 2 | 67 | 75 | 1 | 100 | 300 | 3.5 | 300 | |
| (1) TPB75B - 12 or 18 | 2 | 67 | 75 | 1 | 91 | 300 | 3.5 | 300 | |
| (1) TPB82A - 12 or 18 | 2 | 74 | 82 | 1 | 109 | 300 | 3.5 | 300 | |
| (1) TPB82B - 12 or 18 | 2 | 74 | 82 | 1 | 99 | 300 | 3.5 | 300 | |
| (1) TPB91A - 12 or 18 | 2 | 82 | 91 | 1 | 121 | 300 | 3.5 | 300 | |
| (1) TPB91B - 12 or 18 | 2 | 82 | 91 | 1 | 110 | 300 | 3.5 | 300 | |
| P TPB100A - 12 or 18 | 2 | 90 | 100 | 1 | 133 | 300 | 3.5 | 200 | |
| TPB100B - 12 or 18 | 2 | 90 | 100 | 1 | 121 | 300 | 3.5 | 200 | |
| P TPB110A - 12 or 18 | 2 | 99 | 110 | 1 | 147 | 300 | 3.5 | 200 | Suffix 18 for 180 mA. |
| TPB110B - 12 or 18 | 2 | 99 | 110 | 1 | 133 | 300 | 3.5 | 200 | |
| P TPB120A - 12 or 18 | 2 | 108 | 120 | 1 | 160 | 300 | 3.5 | 200 | |
| TPB120B - 12 or 18 | 2 | 108 | 120 | 1 | 145 | 300 | 3.5 | 200 | |
| P TPB130A - 12 or 18 | 2 | 117 | 130 | 1 | 173 | 300 | 3.5 | 200 | |
| TPB130B - 12 or 18 | 2 | 117 | 130 | 1 | 157 | 300 | 3.5 | 200 | |
| (1) TPB150A - 12 or 18 | 2 | 135 | 150 | 1 | 200 | 300 | 7 | 150 | |
| (1) TPB150B - 12 or 18 | 2 | 135 | 150 | 1 | 181 | 300 | 7 | 150 | |
| (1) TPB160A - 12 or 18 | 2 | 144 | 160 | 1 | 213 | 300 | 7 | 150 | |
| (1) TPB160B - 12 or 18 | 2 | 144 | 160 | 1 | 193 | 300 | 7 | 150 | |
| P TPB180A - 12 or 18 | 2 | 162 | 180 | 1 | 240 | 300 | 7 | 150 | |
| TPB180B - 12 or 18 | 2 | 162 | 180 | 1 | 217 | 300 | 7 | 150 | |
| P TPB200A - 12 or 18 | 2 | 180 | 200 | 1 | 267 | 300 | 7 | 150 | |
| TPB200B - 12 or 18 | 2 | 180 | 200 | 1 | 241 | 300 | 7 | 150 | |
| P TPB220A - 12 or 18 | 2 | 198 | 220 | 1 | 293 | 300 | 7 | 150 | |
| TPB220B - 12 or 18 | 2 | 198 | 220 | 1 | 265 | 300 | 7 | 150 | |
| P TPB240A - 12 or 18 | 2 | 216 | 240 | 1 | 320 | 300 | 7 | 150 | |
| TPB240B - 12 or 18 | 2 | 216 | 240 | 1 | 289 | 300 | 7 | 150 | |
| P TPB270A - 12 or 18 | 2 | 243 | 270 | 1 | 360 | 300 | 7 | 150 | |
| TPB270B - 12 or 18 | 2 | 243 | 270 | 1 | 325 | 300 | 7 | 150 | |

All parameters tested at 25°C, except where indicated.

P : Preferred device.

(1): These voltages are on request

Note 2 : See the reference test circuit for I_H, I_{BO} and V_{BO} parameters.

Note 3 : Square pulse T_p = 1 ms - I_T = 5A.

Note 4 : V_R = 1V, F = 1MHz.

REFERENCE TEST CIRCUIT FOR I_H , I_{BO} and V_{BO} parameters :

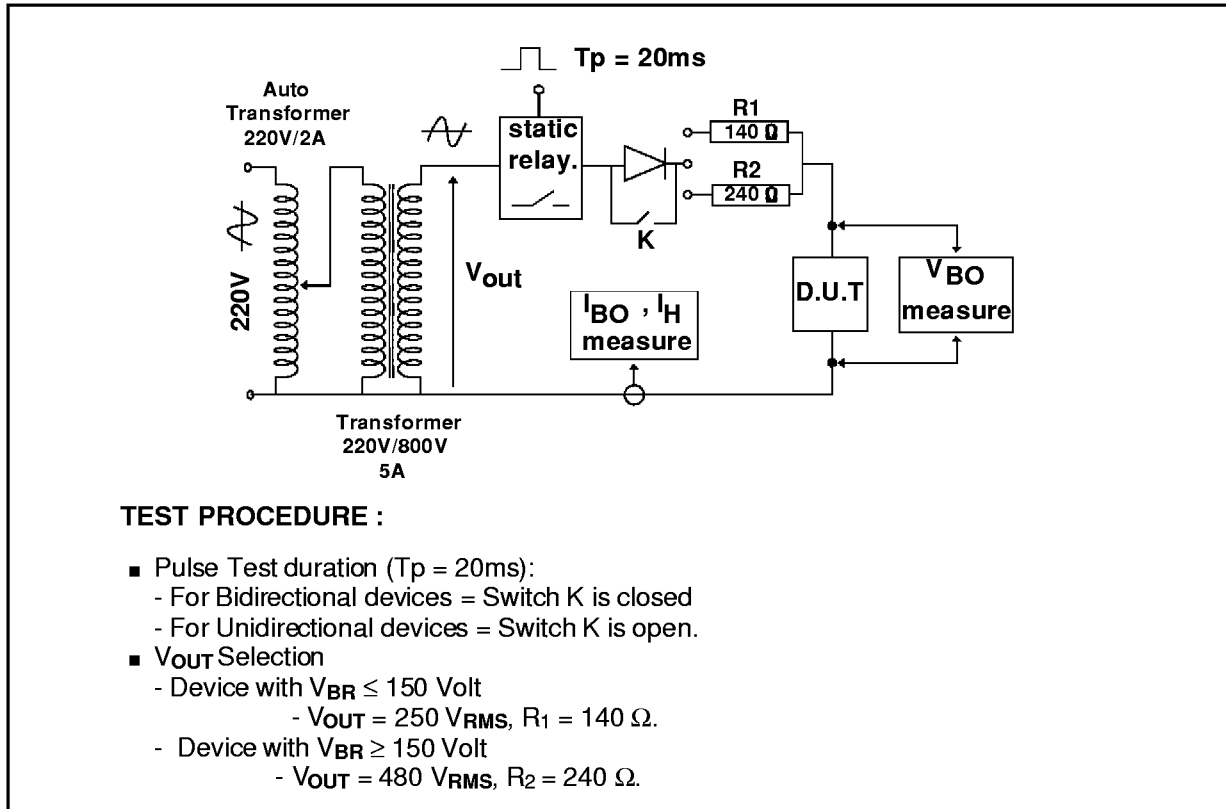

FUNCTIONAL HOLDING CURRENT (I_H) TEST CIRCUIT = GO - NOGO TEST.

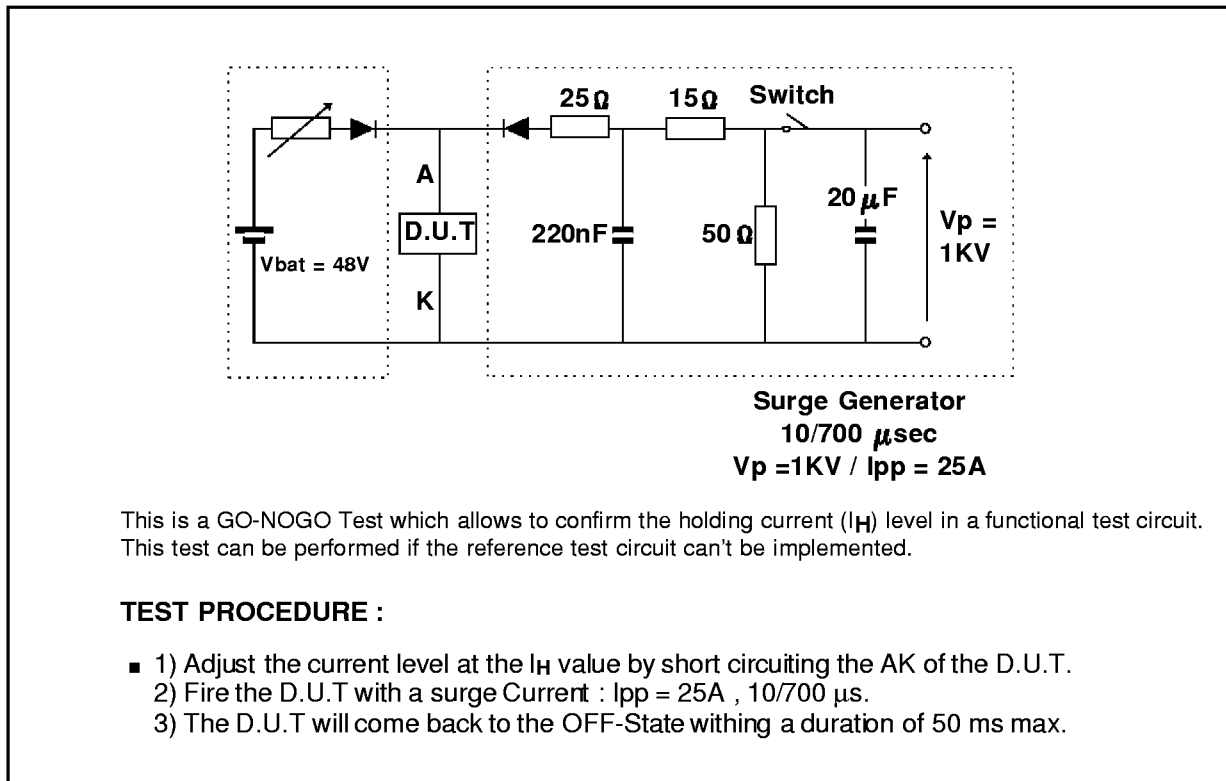

Figure 1 : Non repetitive surge peak on state current versus number of cycles. (with sinusoidal

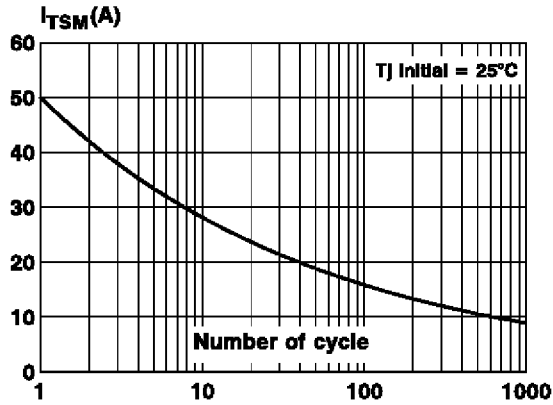

Figure 2 : On - state characteristics (typical values).

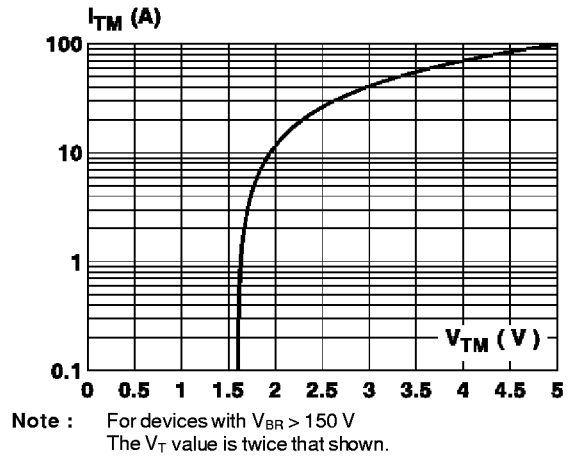
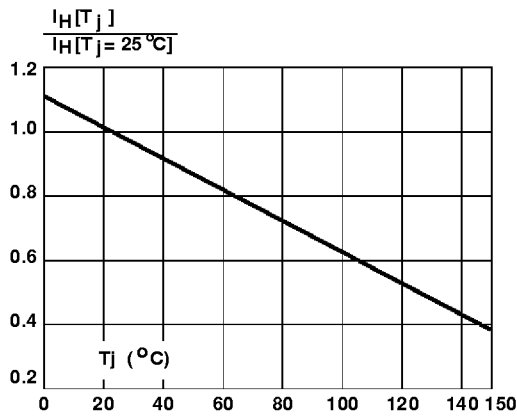
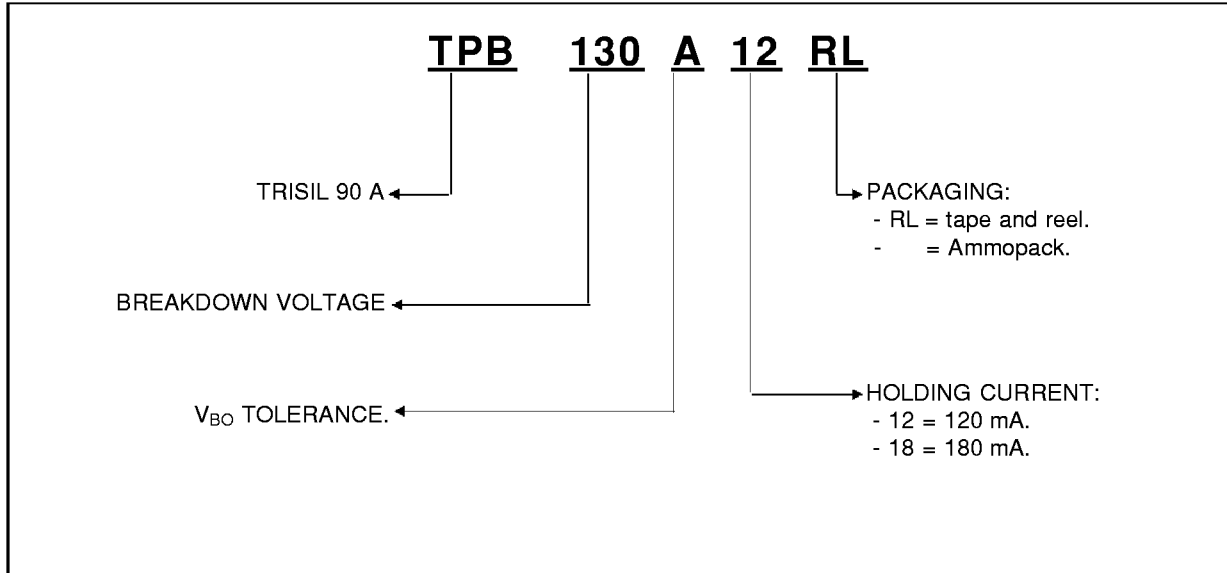

Figure 3 : Relative variation of holding current versus junction temperature.



TPBxxx

ORDER CODE



MARKING : Logo, Date Code, Part Number.

PACKAGE MECHANICAL DATA.

CB 429 Plastic.

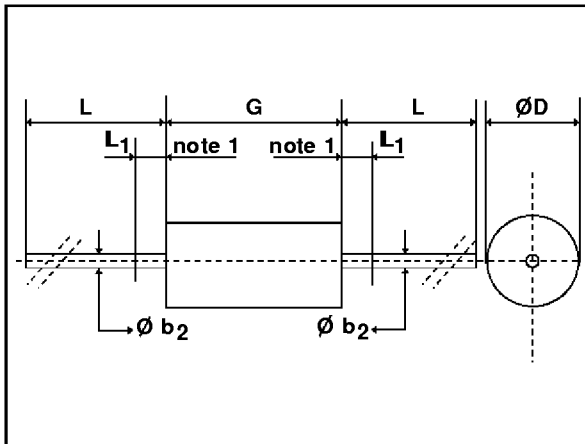

| Ref | Millimeters | | Inches | |
|------------------|-------------|------|--------|-------|
| | min | max | min | max |
| Ø b ₂ | - | 1.06 | - | 0.042 |
| Ø D | - | 5.1 | - | 0.20 |
| G | - | 9.8 | - | 0.386 |
| L | 26 | - | 1.024 | - |
| L ₁ | - | 1.27 | - | 0.050 |

note 1: The diameter Ø b₂ is not controlled over zone L₁.

Packaging : Standard packaging is in tape and reel.

Information furnished is believed to be accurate and reliable. However, SGS-THOMSON Microelectronics assumes no responsibility for the consequences of use of such information nor for any infringement of patents or other rights of third parties which may result from its use. No license is granted by implication or otherwise under any patent or patent rights of SGS-THOMSON Microelectronics. Specifications mentioned in this publication are subject to change without notice. This publication supersedes and replaces all information previously supplied. SGS-THOMSON Microelectronics products are not authorized for use as critical components in life support devices or systems without express written approval of SGS-THOMSON Microelectronics.

© 1994 SGS-THOMSON Microelectronics - All Rights Reserved

Purchase of I²C Components by SGS-THOMSON Microelectronics, conveys a licence under the Philips I²C Patent. Rights to use these components in an I²C system, is granted provided that the system conforms to the I²C Standard Specification as defined by Philips.

SGS-THOMSON Microelectronics GROUP OF COMPANIES
Australia - Brazil - France - Germany - Hong Kong - Italy - Japan - Korea - Malaysia - Malta - Morocco - The Netherlands -
Singapore - Spain - Sweden - Switzerland - Taiwan - Thailand - United Kingdom - U.S.A