

T-52-19

OKI semiconductor

MSM82C84ARS/GS

CLOCK GENERATOR AND DRIVER

GENERAL DESCRIPTION

The MSM82C84ARS/GS is a clock generator designed to generate MSM80C86 and MSM80C88 system clocks. Due to the use of silicon gate CMOS technology, standby current is only 100 μ A (MAX.), and the power consumption is very low with 10 mA (MAX.) when a 5 MHz clock is generated.

FEATURES

- Operating frequency of 6 to 15 MHz (CLK output 2 to 5 MHz)
- 3 μ silicon gate CMOS technology for low power consumption
- Built-in crystal oscillator circuit
- 3V ~ 6V single power supply
- Built-in synchronized circuit for MSM80C86 and MSM80C88 READY and RESET
- TTL compatible
- Built-in Schmitt trigger circuit ($\overline{\text{RES}}$ input)
- 18-pin DIP (MSM82C84ARS)
- 24-pin flat package (MSM82C84AGS)

FUNCTIONAL BLOCK DIAGRAM

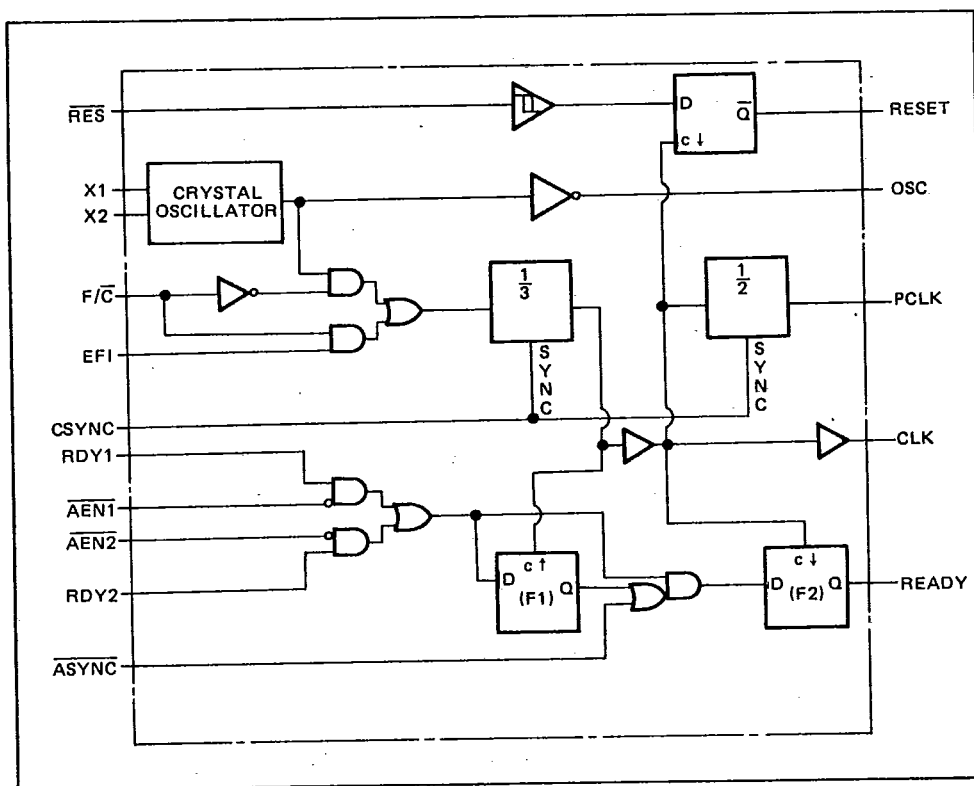

PIN CONFIGURATION

T-52-19

18 Lead Plastic DIP

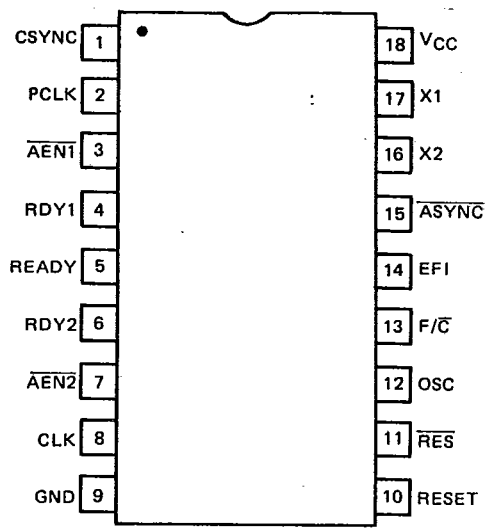

24 Lead Plastic Flat Package

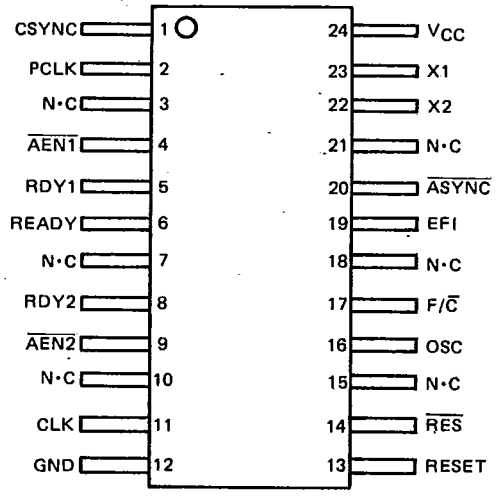

(N-C not connected)

5

T-52-19

ABSOLUTE MAXIMUM RATINGS

Parameter	Symbol	Limits		Unit	Conditions
		MSM82C84ARS	MSM82C84AGS		
Supply Voltage	V _{CC}	-0.5 ~ +7		V	Respect to GND
Input Voltage	V _{IN}	-0.5 ~ V _{CC} +0.5		V	
Output Voltage	V _{OUT}	-0.5 ~ V _{CC} +0.5		V	
Storage Temperature	T _{stg}	-55 ~ +150		°C	-
Power Dissipation	P _D	0.8	0.7	W	T _a = 25°C

OPERATING RANGES

Parameter	Symbol	Limits	Unit
Supply Voltage	V _{CC}	3 ~ 6	V
Operating Temperature	T _{OP}	-40 ~ +85	°C

RECOMMENDED OPERATING CONDITIONS

Parameter	Symbol	MIN	TYP	MAX	Unit
Supply Voltage	V _{CC}	4.5	5	5.5	V
Operating Temperature	T _{OP}	-40	+25	+85	°C
"L" Level Input Voltage	V _{IL}	-0.3		+0.8	V
"H" Level Input Voltage (except \overline{RES})	V _{IH}	2.2		V _{CC} +0.3	V
"H" Level Input Voltage (\overline{RES})		3.0			

DC CHARACTERISTICS

Parameter	Symbol	MIN	MAX	Unit	Conditions
"L" Level Output Voltage	V _{OL}	-	0.45	V	I _{OL} = 5mA
"H" Level Output Voltage	V _{OH}	3.7	-	V	I _{OH} = -1mA
\overline{RES} Input Hysteresis	V _{IHR} -V _{ILR}	0.25	-	V	-
Input Leak Current	I _{LI}	-10	10	μA	0 ≤ V _{IN} ≤ V _{CC}
Standby Supply Current	I _{CCS}	-	100	μA	X1 ≥ V _{CC} -0.2V X2 ≤ 0.2V F/ \overline{C} ≥ V _{CC} -0.2V V _{IH} ≥ V _{CC} -0.2V V _{IL} ≤ 0.2V
Operating Supply Current	I _{CC}	-	10	mA	Input frequency 15 MHz Output load capacitance C _L = 0pF

V_{CC} = 4.5V
~ 5.5V

T_a = -40°C
~ +85°C

5

T-52-19

AC CHARACTERISTICS

(V_{CC} = 5V ±10%, T_a = -40 ~ 85°C)

(1)

Parameter	Symbol	MIN	MAX	Unit	Conditions
EFI "H" Pulse Width	t _{EH} EL	20		ns	90%–90%
EFI "L" Pulse Width	t _{EL} EH	20		ns	10%–10%
EFI Cycle Time	t _E LEL	66		ns	
Crystal Oscillator Frequency		6	16	MHz	
Set Up Time of RDY1 or RDY2 to CLK Falling Edge (Active)	t _R 1VCL	35		ns	ASYNC = High
Set Up Time of RDY1 or RDY2 to CLK Rising Edge (Active)	t _R 1VCH	35		ns	ASYNC = Low
Set Up Time of RDY1 or RDY2 to CLK Falling Edge (Inactive)	t _R 1VCL	35		ns	
Hold Time of RDY1 or RDY2 to CLK Falling Edge	t _C LR1X	0		ns	
Set Up Time of ASYNC to CLK Falling Edge	t _A YVCL	50		ns	
Hold Time of ASYNC to CLK Falling Edge	t _C LAYX	0		ns	
Set Up Time of AEN1 (AEN2) to RDY1 (RDY2) Rising Edge	t _A 1R1V	15		ns	
Hold Time of AEN1 (AEN2) to CLK Falling Edge	t _C LA1X	0		ns	
Set Up Time of CSYNC to EFI Rising Edge	t _Y HEH	20		ns	
Hold Time of CSYNC to EFI Rising Edge	t _E HYL	10		ns	
CSYNC Pulse Width	t _Y HYL	2 × t _E LEL		ns	
Set Up Time of RES to CLK Falling Edge	t _I 1HCL	65		ns	
Hold Time of RES to CLK Falling Edge	t _C L11H	20		ns	
Input Rising Edge Time	t _I LIH		20	ns	
Input Falling Edge Time	t _I HIL		20	ns	

Output load capacitance
CLK output C_L = 100pF
Others 30pF

5

Note: Parameters where timing has not been indicated in the above table are measured at V_L = 1.5V and V_H = 1.5V for both inputs and outputs.

T-52-19

AC CHARACTERISTICS

(V_{CC} = 5V ±10%, T_a = -40 ~ 85°C)

(2)

Parameter	Symbol	MIN	MAX	Unit	Conditions
CLK Cycle Time	t _{CLCL}	200		ns	Output load capacitance CLK output C _L = 100pF Others 30pF
CLK "H" Pulse Width	t _{CHCL}	65		ns	
CLK "L" Pulse Width	t _{CLCH}	119		ns	
CLK Rising and Falling Edge Times	t _{CH1CH2} t _{CL2CL1}		15	ns	
PCLK "H" Pulse Width	t _{PHPL}	180		ns	
PCLK "L" Pulse Width	t _{PLPH}	180		ns	
Time from READY Falling Edge to CLK Falling Edge	t _{RYLCL}	-8		ns	
Time from READY Rising Edge to CLK Rising Edge	t _{RYHCH}	114		ns	
Delay from CLK Falling Edge to RESET Falling Edge	t _{CLIL}		40	ns	
Delay from CLK Falling Edge to PCLK Rising Edge	t _{CLPH}		22	ns	
Delay from CLK Falling Edge to PCLK Falling Edge	t _{CLPL}		22	ns	
Delay from OSC Falling Edge to CLK Rising Edge	t _{OLCH}	-5	22	ns	
Delay from OSC Falling Edge to CLK Falling Edge	t _{OLCL}	2	35	ns	
Output Rising Edge Time (Except CLK)	t _{OLOH}		15	ns	
Output Falling Edge Time (Except CLK)	t _{OHOL}		15	ns	

Note: Parameters where timing has not been indicated in the above table are measured at V_L = 1.5V and V_H = 1.5V for both inputs and outputs.

T-52-19

PIN DESCRIPTION

Pin symbol	Name	Input/output	Function
CSYNC	Clock synchronization signal	Input	Synchronizing signal for output of in-phase CLK signals when more than one MSM82C84A is used. The internal counter is reset when this signal is at high level, and a high level CLK output is generated. The internal counter is subsequently activated and a 33% duty CLK output is generated when this signal is switched to low level. When this signal is used, external synchronization of EFI is necessary. When the internal oscillator is used, it is necessary for this pin to be kept to be low level.
PCLK	Peripheral clock output	Output	This peripheral circuit clock signal is output in a 50% duty cycle at a frequency half that of the clock signal.
$\overline{AEN1}$ $\overline{AEN2}$	Address enable signals	Input	The $\overline{AEN1}$ signal enables RDY1, and the $\overline{AEN2}$ signal enables RDY2. The respective RDY inputs are activated when the level applied to these pins is low. Although two separate inputs are used in multi-master systems, only the \overline{AEN} which enables the RDY input to be used is to be switched to low level in the case of not using multi-master systems.
RDY1 RDY2	Bus ready signals	Input	Completion of data bus reading and writing by the device connected to the system data bus is indicated when one of these signals is switched to high level. The relevant RDY input is enabled only when the corresponding \overline{AEN} is at low level.
READY	Ready output	Output	This signal is obtained by synchronizing the bus ready signal with CLK. This signal is output after guaranteeing the hold time for the CPU in phase with the RDY input.
CLK	Clock output	Output	This signal is the clock used by the CPU and peripheral devices connected to the CPU system data bus. The output waveform is generated in a 33% duty cycle at a frequency 1/3 the oscillating frequency of the crystal oscillator connected to the X1 and X2 pins, or at a frequency 1/3 the EFI input frequency.
RES	Reset in	Input	This low-level active input is used to generate a CPU reset signal. Since a Schmitt trigger is included in the input circuit for this signal, "power on resetting" can be achieved by connection of a simple RC circuit.
RESET	Reset output	Output	This signal is obtained by CLK synchronization of the input signal applied to RES and is output in opposite phase to the \overline{RES} input. This signal is applied to the CPU as the system reset signal.
F/\overline{C}	Clock select signal	Input	This signal selects the fundamental signal for generation of the CLK signal. The CLK is generated from the crystal oscillator output when this signal is at low level, and from the EFI input signal when at high level.
EFI	External clock signal	Input	The signal applied to this input pin generates the CLK signal when F/\overline{C} is at high level. The frequency of the input signal needs to be three times greater than the desired CLK frequency.
X1, X2	Crystal oscillator connecting pins	Input	Crystal oscillator connections. The crystal oscillator frequency needs to be three times greater than the desired CLK frequency.
OSC	Crystal resonator output	Output	Crystal oscillator output. This output frequency is the same as the oscillating frequency of the oscillator connected to the X1 and X2 pins. As long as a Xtal oscillator is connected to the X1 and X2 pins, this output signal can be obtained independently even if F/\overline{C} is set to high level to enable the EFI input to be used for CLK generation purposes.

5

Pin symbol	Name	Input/output	Function
ASYNC	Ready synchronization select signal	Input	Signal for selection of the synchronization mode of the READY signal generator circuit. When this signal is at low level, the READY signal is generated by double synchronization. And when at high level, the READY signal is generated by single synchronization. Since this pin has not been equipped with internal pull-up resistance, this pin must not be opened.
VCC			+5V power supply
GND			GND

TIMING CHART

CLK · PCLK · OSC waveforms

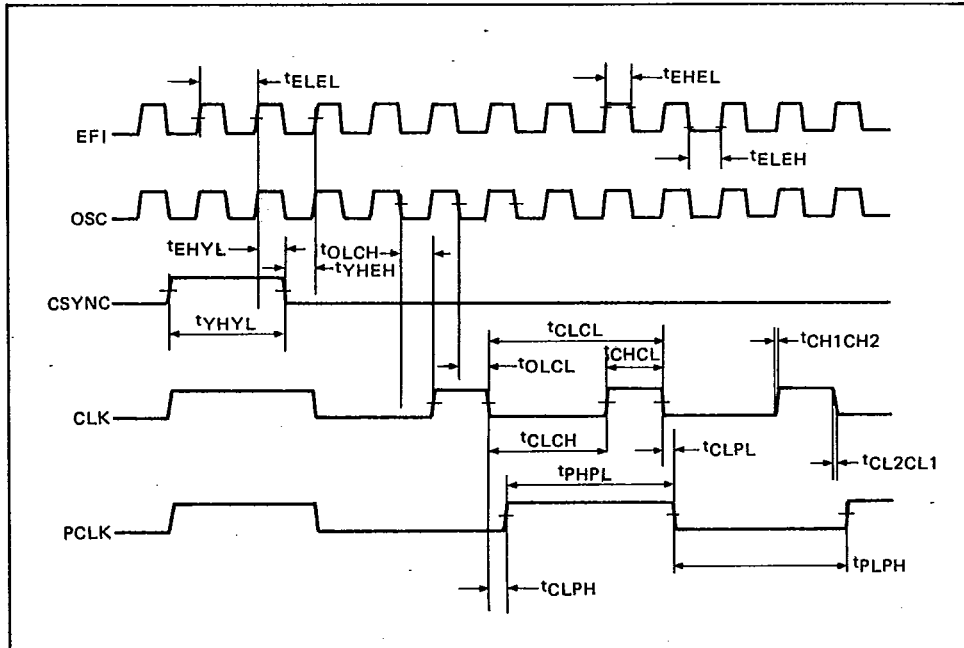

RESET waveform

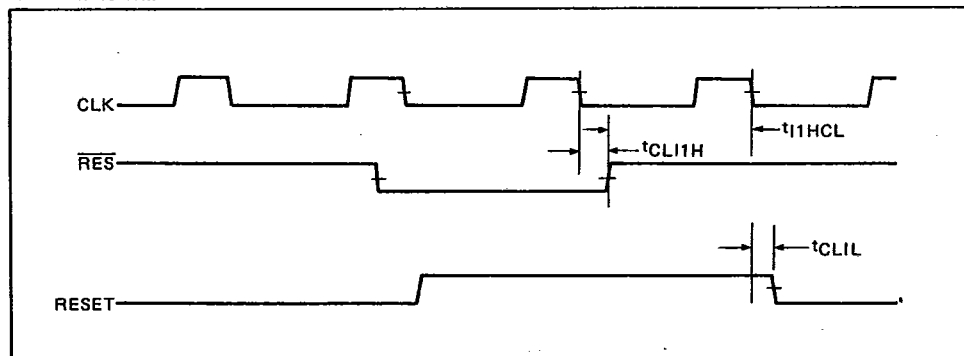

5

T-52-19

READY waveform ($\overline{\text{ASYNC}} = \text{L}$)

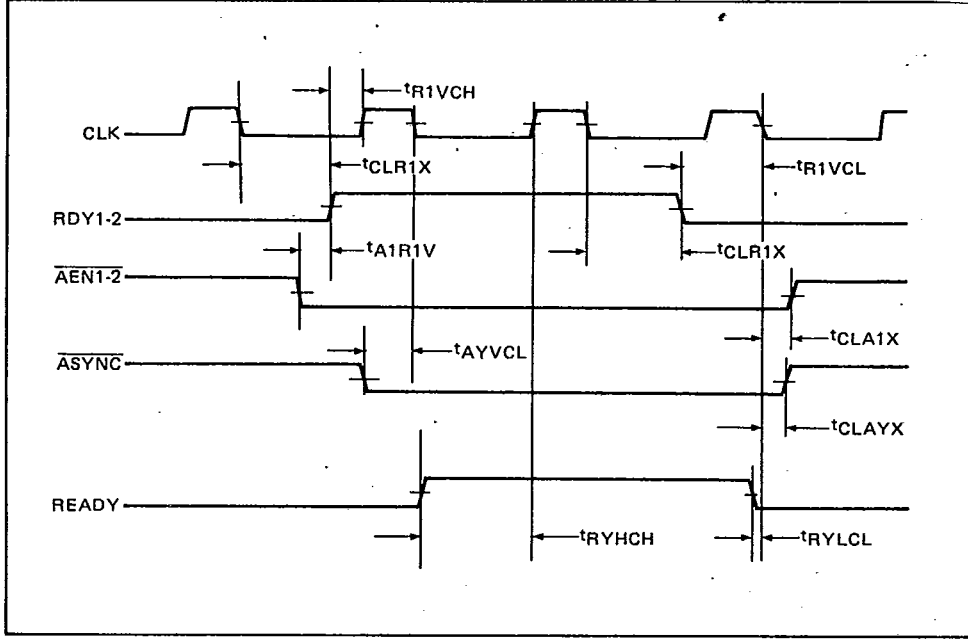

READY waveform ($\overline{\text{ASYNC}} = \text{H}$)

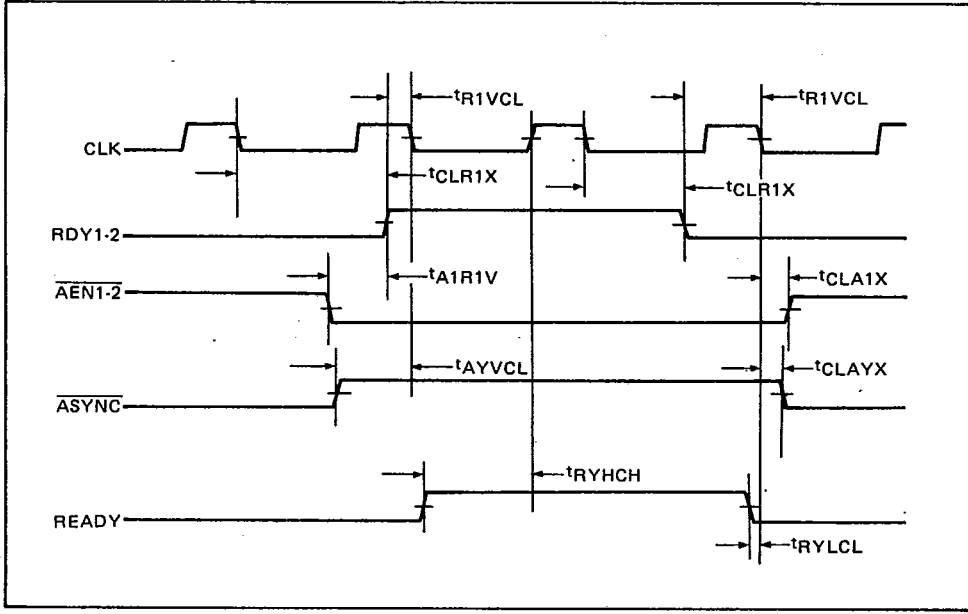

5

T-52-19

DESCRIPTION OF OPERATION

(1) Oscillator Circuit

The MSM82C84A internal oscillator circuit can be driven by connecting a crystal oscillator to the X1 and X2 pins.

The frequency of the crystal oscillator in this case needs to be three times greater than the desired CLK frequency.

Since the oscillator circuit output (the same output as for the crystal resonator frequency) appears at the OSC pin, independent use of this output is also possible.

(2) Clock Generator Circuit

This circuit generates two clock outputs—CLK obtained by dividing the input external clock or crystal oscillator circuit output by three, and PCLK obtained by halving CLK. CLK and PCLK are generated from the external clock applied to the EFI pin when F/C is at high level, and are generated from the crystal oscillator circuit when at low level.

(3) Reset Circuit

Since a Schmitt trigger circuit is used in the RES input, the MSM82C84A can be reset by "power on" by connection to a simple RC circuit. If the 80C86 or 80C88 is used as the CPU in this case, it is necessary to keep the RES input at low level for at least 50 μs after V_{CC} reaches the 4.5V level.

(4) Ready Circuit

The READY signal generator circuit can be set to synchronization mode by ASYNC.

(i) When ASYNC is at low level

The RDY input is output as the READY signal by double synchronization.

The high-level RDY input is synchronized once by the rising edge of the CLK of the first stage flip-flop (F1 in the circuit diagram), and then synchronized again by the falling edge of the CLK of the next stage flip-flop (F2 in the circuit diagram), resulting in output of a high-level READY output signal (see diagram below).

○ The low-level RDY input is synchronized directly by the falling edge of the CLK of the next stage flip-flop, resulting in output of a low-level READY output signal (see diagram below).

Recommended Oscillator Circuit

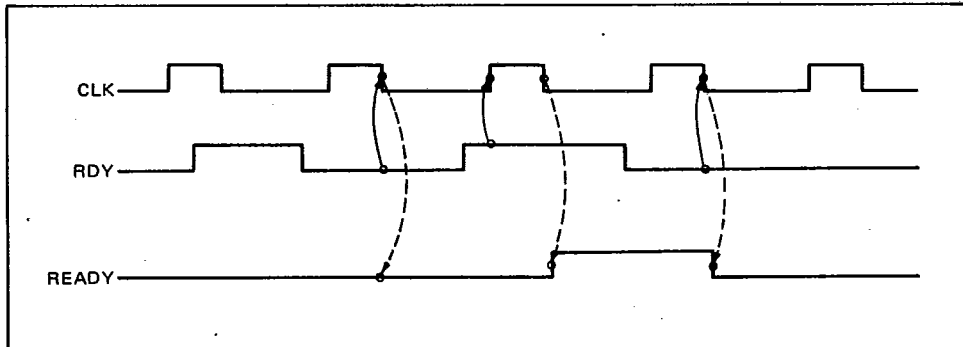
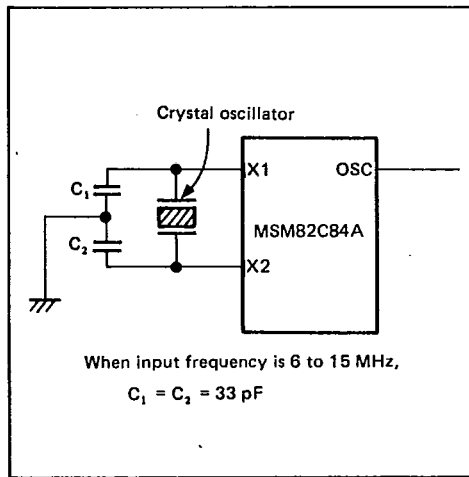

T-52-19

- (ii) When $\overline{\text{ASYNC}}$ is at high level
 The RDY input is output as the READY signal by single synchronization.
 o Both low-level and high-level RDY inputs are

synchronized by the falling edge of the CLK of the next stage flip-flop, resulting in output of respective low-level and high-level READY output signals (see diagram below).

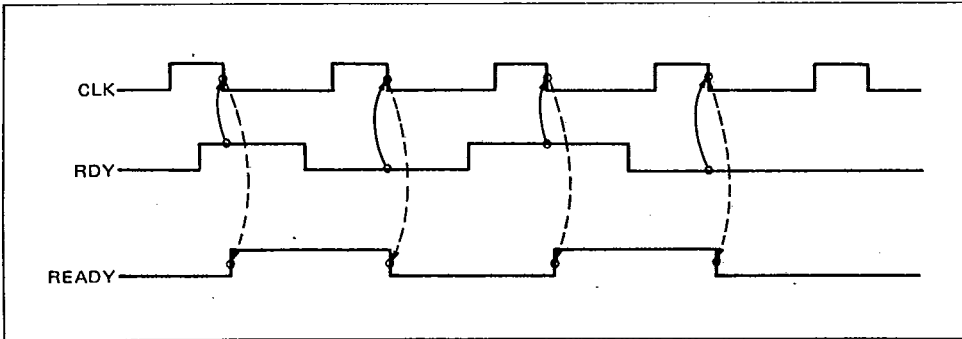

EXAMPLE OF USE (CSYNC)

The 82C84A 1/3 frequency divider counter is unsettled when the power is switched on. Therefore, the CSYNC pin has been included to synchronize CLK with another signal. When CSYNC is at high level, both CLK and PCLK are high-level outputs. If CSYNC is then

switched to low level, CLK is output from the next input clock rising edge, and is divided by 3.

If CSYNC has not been synchronized with the input clock, use the following circuit to achieve the required synchronization.

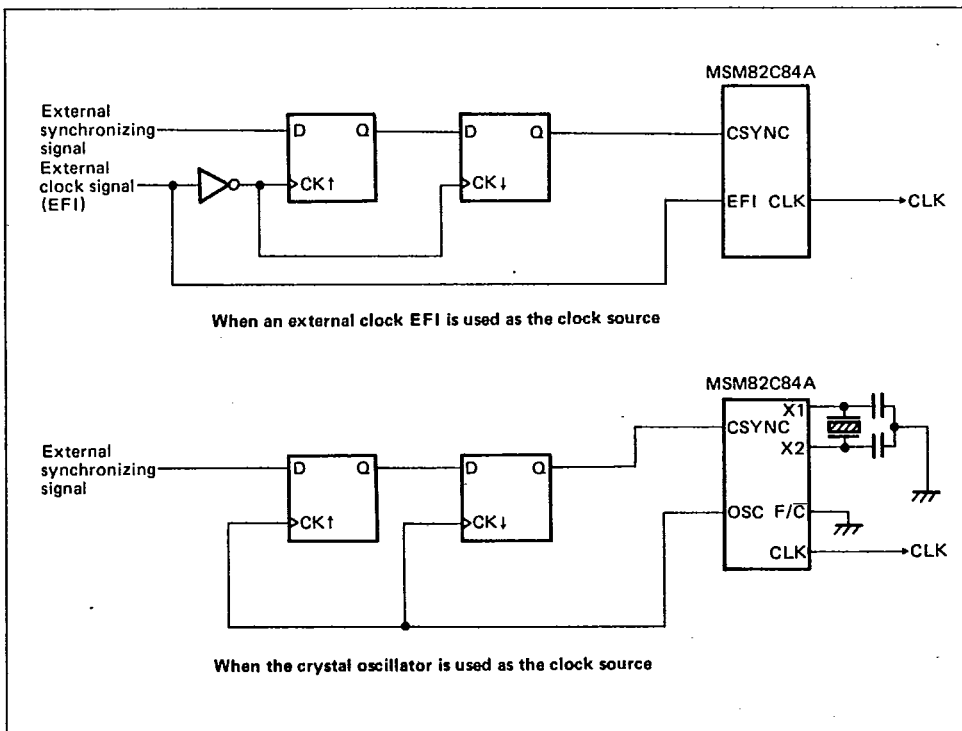

5