



Integrated Device Technology, Inc.

# FAST CMOS OCTAL BUFFER/LINE DRIVER

IDT54/74FCT240/A/C  
IDT54/74FCT241/A/C  
IDT54/74FCT244/A/C  
IDT54/74FCT540/A/C  
IDT54/74FCT541/A/C

## FEATURES:

- IDT54/74FCT240/241/244/540/541 equivalent to FAST™ speed and drive
- **IDT54/74FCT240A/241A/244A/540A/541A 25% faster than FAST**
- **IDT54/74FCT240C/241C/244C/540C/541C up to 55% faster than FAST**
- $I_{OL} = 64\text{mA}$  (commercial) and  $48\text{mA}$  (military)
- CMOS power levels ( $1\text{mW}$  typ. static)
- Product available in Radiation Tolerant and Radiation Enhanced versions
- Military product compliant to MIL-STD-883, Class B
- Meets or exceeds JEDEC Standard 18 specifications

## DESCRIPTION:

The IDT octal buffer/line drivers are built using an advanced dual metal CMOS technology. The IDT54/74FCT240/A/C, IDT54/74FCT241/A/C and IDT54/74FCT244/A/C are designed to be employed as memory and address drivers, clock drivers and bus-oriented transmitter/receivers which provide improved board density.

The IDT54/74FCT540/A/C and IDT54/74FCT541/A/C are similar in function to the IDT54/74FCT240/A/C and IDT54/74FCT244/A/C, respectively, except that the inputs and outputs are on opposite sides of the package. This pinout arrangement makes these devices especially useful as output ports for microprocessors and as backplane drivers, allowing ease of layout and greater board density.

## FUNCTIONAL BLOCK DIAGRAMS

2529 cnv\* 01-03

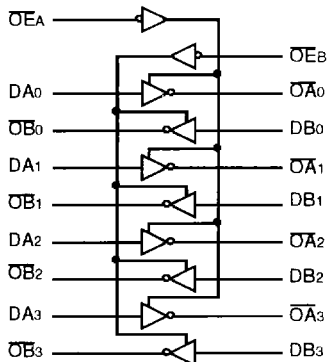

IDT54/74FCT240

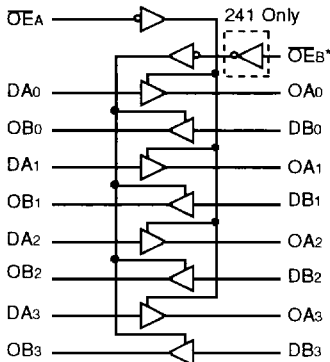

IDT54/74FCT241/244

\*OE<sub>B</sub> for 241, OE<sub>B</sub> for 244

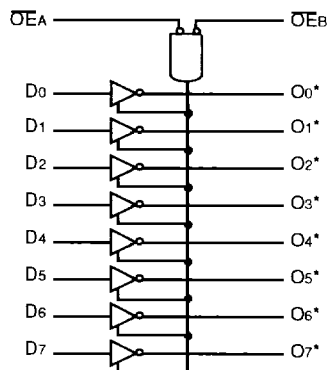

IDT54/74FCT540/541

\*Logic diagram shown for 'FCT540.  
'FCT541 is the non-inverting option.

2606 dwg 01-03

7

The IDT logo is a registered trademark of Integrated Device Technology, Inc.  
FAST is a trademark of National Semiconductor Co.

**PIN CONFIGURATIONS**

**IDT54/74FCT240**

2529 cnv\* 04-09

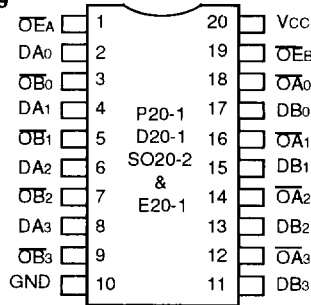

**DIP/SOIC/CERPACK  
TOP VIEW**

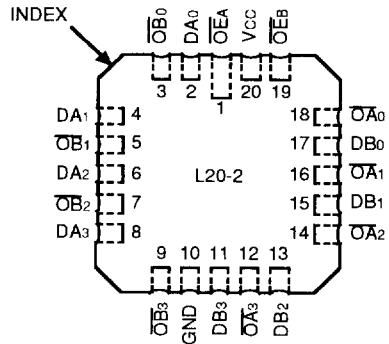

**LCC  
TOP VIEW**

**IDT54/74FCT241/244**

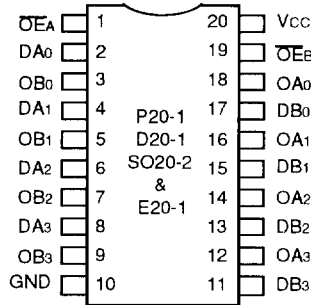

**DIP/SOIC/CERPACK  
TOP VIEW**

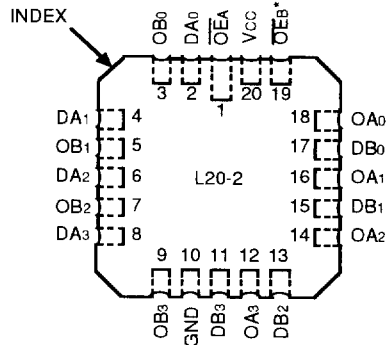

**LCC  
TOP VIEW**

\*OEb for 241. OEa for 244

**IDT54/74FCT540/541**

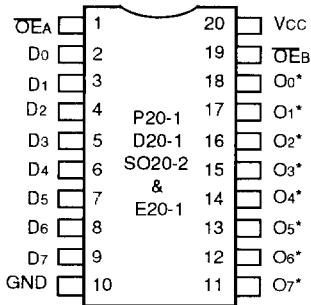

**DIP/SOIC/CERPACK  
TOP VIEW**

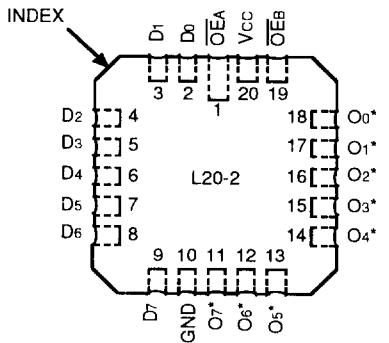

**LCC  
TOP VIEW**

\*Ox for 540, Ox for 541

2606 cnv\* 04-09

**PIN DESCRIPTION**

Pin Names	Description
$\overline{OE}A, \overline{OE}B$	3-State Output Enable Inputs (Active LOW)
$\overline{OE}B^{(1)}$	3-State Output Enable Input (Active HIGH)
Dxx	Inputs
Oxx	Outputs

**NOTES:**  
 1.  $\overline{OE}B$ s for 241 only.

2606 tbl 04

**FUNCTION TABLE**

Inputs <sup>(1)</sup>				Outputs <sup>(1)</sup>				
$\overline{OE}A$	$\overline{OE}B$	$\overline{OE}B^{(2)}$	D	240	241	244	540	541
L	L	H	L	H	L	L	H	L
L	L	H	H	L	H	H	L	H
H	H	L	X	Z	Z	Z	Z	Z

**NOTES:**  
 1. H = High Voltage Level  
 X = Don't Care  
 L = Low Voltage Level  
 Z = High Impedance  
 2.  $\overline{OE}B$ s for 241 only.

2606 tbl 05

**ABSOLUTE MAXIMUM RATINGS<sup>(1)</sup>**

Symbol	Rating	Commercial	Military	Unit
$V_{TERM}^{(2)}$	Terminal Voltage with Respect to GND	-0.5 to +7.0	-0.5 to +7.0	V
$V_{TERM}^{(3)}$	Terminal Voltage with Respect to GND	-0.5 to $V_{CC}$	-0.5 to $V_{CC}$	V
$T_A$	Operating Temperature	0 to +70	-55 to +125	°C
$T_{BIAS}$	Temperature Under Bias	-55 to +125	-65 to +135	°C
$T_{STG}$	Storage Temperature	-55 to +125	-65 to +150	°C
$P_T$	Power Dissipation	0.5	0.5	W
$I_{OUT}$	DC Output Current	120	120	mA

**NOTES:**  
 1. Stresses greater than those listed under ABSOLUTE MAXIMUM RATINGS may cause permanent damage to the device. This is a stress rating only and functional operation of the device at these or any other conditions above those indicated in the operational sections of this specification is not implied. Exposure to absolute maximum rating conditions for extended periods may affect reliability. No terminal voltage may exceed  $V_{CC}$  by +0.5V unless otherwise noted.  
 2. Input and  $V_{CC}$  terminals only.  
 3. Outputs and I/O terminals only.

2606 tbl 01

**CAPACITANCE** ( $T_A = +25^\circ\text{C}$ ,  $f = 1.0\text{MHz}$ )

Symbol	Parameter <sup>(1)</sup>	Conditions	Typ.	Max.	Unit
$C_{IN}$	Input Capacitance	$V_{IN} = 0V$	6	10	pF
$C_{OUT}$	Output Capacitance	$V_{OUT} = 0V$	8	12	pF

**NOTE:**  
 1. This parameter is measured at characterization but not tested.

2606 tbl 02



**DC ELECTRICAL CHARACTERISTICS OVER OPERATING RANGE**

Following Conditions Apply Unless Otherwise Specified:  $V_{LC} = 0.2V$ ;  $V_{HC} = V_{CC} - 0.2V$

Commercial:  $T_A = 0^{\circ}C$  to  $+70^{\circ}C$ ,  $V_{CC} = 5.0V \pm 5\%$ ; Military:  $T_A = -55^{\circ}C$  to  $+125^{\circ}C$ ,  $V_{CC} = 5.0V \pm 10\%$

Symbol	Parameter	Test Conditions <sup>(1)</sup>		Min.	Typ. <sup>(2)</sup>	Max.	Unit
$V_{IH}$	Input HIGH Level	Guaranteed Logic HIGH Level		2.0	—	—	V
$V_{IL}$	Input LOW Level	Guaranteed Logic LOW Level		—	—	0.8	V
$I_{IH}$	Input HIGH Current	$V_{CC} = \text{Max.}$	$V_I = V_{CC}$	—	—	5	$\mu A$
$I_{IL}$	Input LOW Current		$V_I = 2.7V$	—	—	5 <sup>(4)</sup>	
			$V_I = 0.5V$	—	—	-5 <sup>(4)</sup>	
			$V_I = GND$	—	—	-5	
$I_{OZH}$	Off State (High Impedance) Output Current	$V_{CC} = \text{Max.}$	$V_O = V_{CC}$	—	—	10	$\mu A$
$I_{OZL}$			$V_O = 2.7V$	—	—	10 <sup>(4)</sup>	
			$V_O = 0.5V$	—	—	-10 <sup>(4)</sup>	
			$V_O = GND$	—	—	-10	
$V_{IK}$	Clamp Diode Voltage	$V_{CC} = \text{Min.}, I_N = -18mA$		—	-0.7	-1.2	V
$I_{OS}$	Short Circuit Current	$V_{CC} = \text{Max.}^{(3)}, V_O = GND$		-60	-120	—	mA
$V_{OH}$	Output HIGH Voltage	$V_{CC} = 3V, V_{IN} = V_{LC}$ or $V_{HC}, I_{OH} = -32\mu A$		$V_{HC}$	$V_{CC}$	—	V
		$V_{CC} = \text{Min.}$ $V_{IN} = V_{IH}$ or $V_{IL}$	$I_{OH} = -300\mu A$	$V_{HC}$	$V_{CC}$	—	
			$I_{OH} = -12mA$ MIL.	2.4	4.3	—	
			$I_{OH} = -15mA$ COM'L.	2.4	4.3	—	
$V_{OL}$	Output LOW Voltage	$V_{CC} = 3V, V_{IN} = V_{LC}$ or $V_{HC}, I_{OL} = 300\mu A$		—	GND	$V_{LC}$	V
		$V_{CC} = \text{Min.}$ $V_{IN} = V_{IH}$ or $V_{IL}$	$I_{OL} = 300\mu A$	—	GND	$V_{LC}^{(4)}$	
			$I_{OL} = 48mA$ MIL.	—	0.3	0.55	
			$I_{OL} = 64mA$ COM'L.	—	0.3	0.55	

**NOTES:**

- For conditions shown as Max. or Min., use appropriate value specified under Electrical Characteristics for the applicable device type.
- Typical values are at  $V_{CC} = 5.0V$ ,  $+25^{\circ}C$  ambient and maximum loading.
- Not more than one output should be shorted at one time. Duration of the short circuit test should not exceed one second.
- This parameter is guaranteed but not tested.

2606 tbi 03

**POWER SUPPLY CHARACTERISTICS**

$V_{LC} = 0.2V$ ;  $V_{HC} = V_{CC} - 0.2V$

Symbol	Parameter	Test Conditions <sup>(1)</sup>		Min.	Typ. <sup>(2)</sup>	Max.	Unit
I <sub>CC</sub>	Quiescent Power Supply Current	V <sub>CC</sub> = Max. V <sub>IN</sub> ≥ V <sub>HC</sub> ; V <sub>IN</sub> ≤ V <sub>LC</sub>		—	0.2	1.5	mA
ΔI <sub>CC</sub>	Quiescent Power Supply Current TTL Inputs HIGH	V <sub>CC</sub> = Max. V <sub>IN</sub> = 3.4V <sup>(3)</sup>		—	0.5	2.0	mA
I <sub>CCD</sub>	Dynamic Power Supply Current <sup>(4)</sup>	V <sub>CC</sub> = Max. Outputs Open OE <sub>A</sub> = OE <sub>B</sub> = GND or OE <sub>A</sub> = GND, OE <sub>B</sub> = V <sub>CC</sub> One Input Toggling 50% Duty Cycle	V <sub>IN</sub> ≥ V <sub>HC</sub> V <sub>IN</sub> ≤ V <sub>LC</sub>	—	0.15	0.25	mA/ MHz
I <sub>C</sub>	Total Power Supply Current <sup>(6)</sup>	V <sub>CC</sub> = Max. Outputs Open f <sub>i</sub> = 10MHz 50% Duty Cycle OE <sub>A</sub> = OE <sub>B</sub> = GND or OE <sub>A</sub> = GND, OE <sub>B</sub> = V <sub>CC</sub> One Bit Toggling	V <sub>IN</sub> ≥ V <sub>HC</sub> V <sub>IN</sub> ≤ V <sub>LC</sub> (FCT)	—	1.7	4.0	mA
			V <sub>IN</sub> = 3.4V V <sub>IN</sub> = GND	—	2.0	5.0	
		V <sub>CC</sub> = Max. Outputs Open f <sub>i</sub> = 5MHz 50% Duty Cycle OE <sub>A</sub> = OE <sub>B</sub> = GND or OE <sub>A</sub> = GND, OE <sub>B</sub> = V <sub>CC</sub> Eight Bits Toggling	V <sub>IN</sub> ≥ V <sub>HC</sub> V <sub>IN</sub> ≤ V <sub>LC</sub> (FCT)	—	3.2	6.5 <sup>(5)</sup>	
			V <sub>IN</sub> = 3.4V V <sub>IN</sub> = GND	—	5.2	14.5 <sup>(5)</sup>	

**NOTES:**

- For conditions shown as Max. or Min., use appropriate value specified under Electrical Characteristics for the applicable device type.
- Typical values are at V<sub>CC</sub> = 5.0V, +25°C ambient.
- Per TTL driven input (V<sub>IN</sub> = 3.4V); all other inputs at V<sub>CC</sub> or GND.
- This parameter is not directly testable, but is derived for use in Total Power Supply Calculations.
- Values for these conditions are examples of the I<sub>CC</sub> formula. These limits are guaranteed but not tested.
- I<sub>C</sub> = I<sub>QUIESCENT</sub> + I<sub>INPUTS</sub> + I<sub>DYNAMIC</sub>  
 $I_C = I_{CC} + \Delta I_{CC} D_{HT} + I_{CCD} (f_{CP}/2 + f_i N_i)$   
 I<sub>CC</sub> = Quiescent Current  
 ΔI<sub>CC</sub> = Power Supply Current for a TTL High Input (V<sub>IN</sub> = 3.4V)  
 D<sub>HT</sub> = Duty Cycle for TTL Inputs High  
 N<sub>T</sub> = Number of TTL Inputs at D<sub>HT</sub>  
 I<sub>CCD</sub> = Dynamic Current Caused by an Input Transition Pair (HLH or LHL)  
 f<sub>CP</sub> = Clock Frequency for Register Devices (Zero for Non-Register Devices)  
 f<sub>i</sub> = Input Frequency  
 N<sub>i</sub> = Number of Inputs at f<sub>i</sub>  
 All currents are in milliamps and all frequencies are in megahertz.

2606 tbl 06



**SWITCHING CHARACTERISTICS OVER OPERATING RANGE FOR FCT240<sup>(1,2)</sup>**

Symbol	Parameter	Condition	54/74FCT240		54/74FCT240A				54/74FCT240C				Unit		
			Com'l.		Mil.		Com'l.		Mil.		Com'l.			Mil.	
			Min.	Max.	Min.	Max.	Min.	Max.	Min.	Max.	Min.	Max.		Min.	Max.
tPLH tPHL	Propagation Delay DN to ON	CL = 50pF RL = 500Ω	1.5	8.0	1.5	9.0	1.5	4.8	1.5	5.1	1.5	4.3	1.5	4.7	ns
tPZH tPZL	Output Enable Time		1.5	10.0	1.5	10.5	1.5	6.2	1.5	6.5	1.5	5.8	1.5	6.5	ns
tPHZ tPLZ	Output Disable Time		1.5	9.5	1.5	10.0	1.5	5.6	1.5	5.9	1.5	5.2	1.5	5.7	ns

2606 tbl 07

SWITCHING CHARACTERISTICS OVER OPERATING RANGE FOR FCT241 AND FCT244<sup>(1,2)</sup>

**SWITCHING CHARACTERISTICS OVER OPERATING RANGE FOR FCT241 AND FCT244<sup>(1,2)</sup>**

Symbol	Parameter	Condition	54/74FCT241/244		54/74FCT241A/244A				54/74FCT241C/244C				Unit		
			Com'l.		Mil.		Com'l.		Mil.		Com'l.			Mil.	
			Min.	Max.	Min.	Max.	Min.	Max.	Min.	Max.	Min.	Max.		Min.	Max.
tPLH tPHL	Propagation Delay DN to ON	CL = 50pF RL = 500Ω	1.5	6.5	1.5	7.0	1.5	4.8	1.5	5.1	1.5	4.1	1.5	4.6	ns
tPZH tPZL	Output Enable Time		1.5	8.0	1.5	8.5	1.5	6.2	1.5	6.5	1.5	5.8	1.5	6.5	ns
tPHZ tPLZ	Output Disable Time		1.5	7.0	1.5	7.5	1.5	5.6	1.5	5.9	1.5	5.2	1.5	5.7	ns

2606 tbl 08

**SWITCHING CHARACTERISTICS OVER OPERATING RANGE FOR FCT540 AND FCT541<sup>(1,2)</sup>**

Symbol	Parameter	Condition	54/74FCT540/541		54/74FCT540A/541A				54/74FCT540C/541C				Unit		
			Com'l.		Mil.		Com'l.		Mil.		Com'l.			Mil.	
			Min.	Max.	Min.	Max.	Min.	Max.	Min.	Max.	Min.	Max.		Min.	Max.
tPLH tPHL	Propagation Delay DN to ON IDT54/74FCT540	CL = 50pF RL = 500Ω	1.5	8.5	1.5	9.5	1.5	4.8	1.5	5.1	1.5	4.3	1.5	4.7	ns
tPLH tPHL	Propagation Delay DN to ON IDT54/74FCT541		1.5	8.0	1.5	9.0	1.5	4.8	1.5	5.1	1.5	4.1	1.5	4.6	ns
tPZH tPZL	Output Enable Time		1.5	10.0	1.5	10.5	1.5	6.2	1.5	6.5	1.5	5.8	1.5	6.5	ns
tPHZ tPLZ	Output Disable Time		1.5	9.5	1.5	10.0	1.5	5.6	1.5	5.9	1.5	5.2	1.5	5.7	ns

**NOTES:**

1. See test circuit and waveforms.
2. Minimum limits are guaranteed but not tested on Propagation Delays.

2606 tbl 09

TEST CIRCUITS AND WAVEFORMS

TEST CIRCUITS FOR ALL OUTPUTS

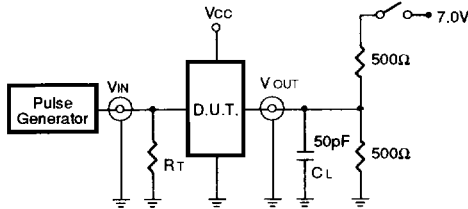

SWITCH POSITION

Test	Switch
Open Drain Disable Low Enable Low	Closed
All Other Tests	Open

DEFINITIONS:

CL = Load capacitance: includes jig and probe capacitance.  
RT = Termination resistance: should be equal to ZOUT of the Pulse Generator.

2606 tbl 10

SET-UP, HOLD AND RELEASE TIMES

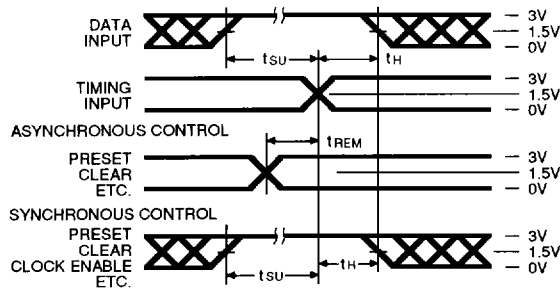

PULSE WIDTH

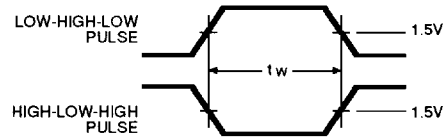

PROPAGATION DELAY

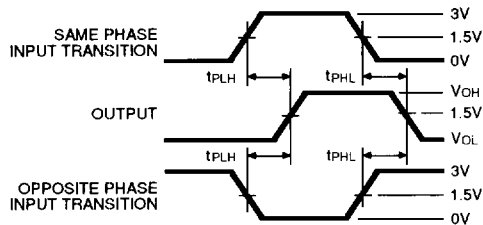

ENABLE AND DISABLE TIMES

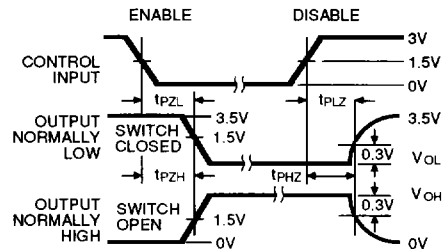

NOTES

- Diagram shown for input Control Enable-LOW and input Control Disable-HIGH.
- Pulse Generator for All Pulses: Rate  $\leq 1.0$  MHz;  $Z_0 \leq 50\Omega$ ;  $t_r \leq 2.5$  ns;  $t_n \leq 2.5$  ns.

2606 drw 10

ORDERING INFORMATION

IDT	XX	FCT	XXXX	X	X	
Temp. Range			Device Type	Package	Process	
						Blank
						B Commercial MIL-STD-883, Class B
						P Plastic DIP
						D CERDIP
						SO Small Outline IC
						L Leadless Chip Carrier
						E CERPACK
						240 Inverting Octal Buffer/Line Driver
						241 Non-Inverting Octal Buffer/Line Driver
						244 Non-Inverting Octal Buffer/Line Driver
						540 Inverting Octal Buffer/Line Driver
						541 Non-Inverting Octal Buffer/Line Driver
						240A Fast Inverting Octal Buffer/Line Driver
						241A Fast Non-Inverting Octal Buffer/Line Driver
						244A Fast Non-Inverting Octal Buffer/Line Driver
						540A Fast Inverting Octal Buffer/Line Driver
						541A Fast Non-Inverting Octal Buffer/Line Driver
						240C Super Fast Inverting Octal Buffer/Line Driver
						241C Super Fast Non-Inverting Octal Buffer/Line Driver
						244C Super Fast Non-Inverting Octal Buffer/Line Driver
						540C Super Fast Inverting Octal Buffer/Line Driver
						541C Super Fast Non-Inverting Octal Buffer/Line Driver
						54 -55°C to +125°C
						74 0°C to +70°C

2606 cnv\* 15