

Available Q2, 1995

Dual JK Positive Edge-Triggered Flip-Flop

This device consists of two high speed JK flip flops. Both normal and inverted outputs are available. The device can be asynchronously set or reset, or synchronously clocked.

- Advanced very high speed CMOS
- Outputs source/sink 24 mA
- Transmission line driving 50 ohms
- ACT has TTL compatible inputs
- AC Device Operation from 2 to 6 volts guaranteed
- DC & AC Parameters guaranteed over -40 to +85°C

DV74AC109
DV74ACT109

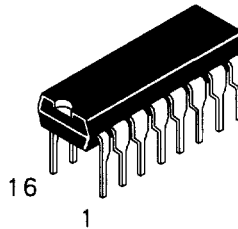

N Suffix
Plastic DIP
AVG-003 Case

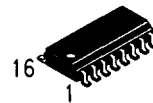

D Suffix
Plastic SOP
AVG-004 Case

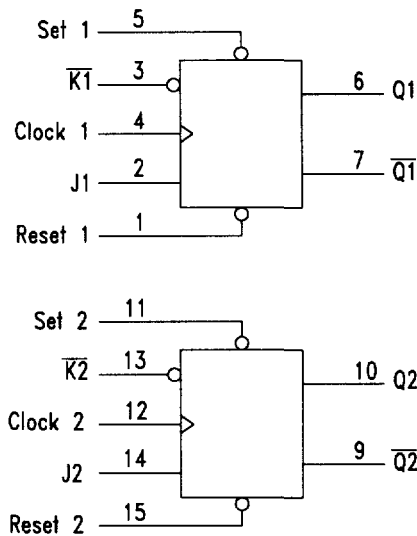

PIN 16 = V_{CC}
PIN 8 = GND

PIN ASSIGNMENT

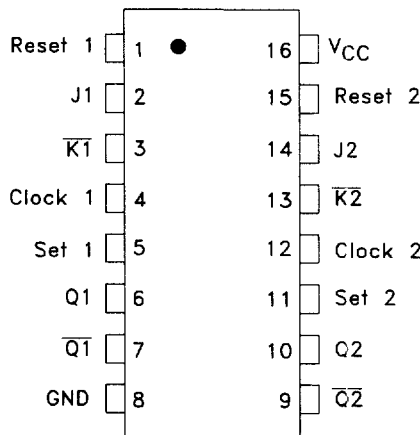

TRUTH TABLE

Inputs					Output	
Set	Reset	Clock	J	K	Q	Q̄
L	H	X	X	X	H	L
H	L	X	X	X	L	H
L	L	X	X	X	H*	H*
H	H	↑	L	L	L	H
H	H	↑	H	L	Toggle	Toggle
H	H	↑	L	H	Q _o	Q _o
H	H	↑	H	H	H	L
H	H	L	X	X	Q _o	Q̄ _o

H=High Logic Level L=Low Logic Level
X=Don't Care Q_o=Previous State of Q
↑ = Low to High Transition
* Both outputs will remain high as long as Set and Reset are low, but the output states are unpredictable if Set and Reset go high simultaneously

ABSOLUTE MAXIMUM RATINGS

Maximum ratings are those values beyond which damage to the device may occur.

Symbol	Parameter	AC109, ACT109	Unit
V _{CC}	DC Supply Voltage (Referenced to GND)	- 0.5 to +7.0	V
V _{IN}	DC Input Voltage (Referenced to GND)	- 0.5 to V _{CC} +0.5	V
V _{OUT}	DC Output Voltage (Referenced to GND)	- 0.5 to V _{CC} +0.5	V
I _{IN}	DC Input Current, per Pin	± 20	mA
I _{OUT}	DC Output Sink/Source Current, per Pin	± 50	mA
I _{CC}	DC V _{CC} or GND Current per Output Pin	± 50	mA
T _{stg}	Storage Temperature	- 65 to +150	°C

GUARANTEED OPERATING CONDITIONS

Symbol	Parameter	Min	Typ	Max	Unit	
V _{CC}	Supply Voltage	'AC	2.0	5.0	6.0	V
		'ACT	4.5	5.0	5.5	
V _{IN} , V _{OUT}	DC Input Voltage, Output Voltage, (Ref. to GND)	0		V _{CC}	V	
t _r , t _f	Input Rise and Fall Time (Note 1) 'AC Devices	V _{CC} @ 3.0 V		150	ns/V	
		V _{CC} @ 4.5 V		40	ns/V	
		V _{CC} @ 5.5 V		25	ns/V	
t _r , t _f	Input Rise and Fall Time (Note 2) 'ACT Devices	V _{CC} @ 4.5 V		10	ns/V	
		V _{CC} @ 5.5 V		8.0	ns/V	
T _A	Operating Ambient Temperature Range	-40	25	85	°C	
C _{IN}	Input Capacitance	V _{CC} = 5.0 V	4.5		pF	
C _{PD}	Power Dissipation Capacitance	V _{CC} = 5.0 V	35		pF	

1. V_{IN} from 30% to 70% V_{CC}

2. V_{IN} from 0.8 to 2.0 V

AC — 109

DC ELECTRICAL CHARACTERISTICS

Symbol	Parameter	Conditions	V _{CC} (V)	AC109			Unit		
				T _A = +25°C		T _A = -40 to +85°C			
				Typ	Guaranteed Limits				
V _{IH}	Minimum High Level Input Voltage	V _{OUT} = 0.1V or V _{CC} - 0.1 V	3.0	1.5	2.1	2.1	V		
			4.5	2.25	3.15	3.15			
			5.5	2.75	3.85	3.85			
V _{IL}	Maximum Low Level Input Voltage	V _{OUT} = 0.1V or V _{CC} - 0.1 V	3.0	1.5	0.9	0.9	V		
			4.5	2.25	1.35	1.35			
			5.5	2.75	1.65	1.65			
V _{OH}	Minimum High Level Output Voltage	I _{OUT} = -50 μA	3.0	2.99	2.9	2.9	V		
			4.5	4.49	4.4	4.4			
			5.5	5.49	5.4	5.4			
		V _{IN} = V _{IL} or V _{IH}	I _{OH}	-12mA	3.0		2.56	2.46	V
				-24mA	4.5		3.86	3.76	
		-24mA	5.5		4.86	4.76			

109

DC ELECTRICAL CHARACTERISTICS (continued)

Symbol	Parameter	Conditions	V _{CC} (V)	AC109			Unit	
				TA = +25°C		TA = -40 to +85°C		
				Typ	Guaranteed Limits			
V _{OL}	Maximum Low Level Output Voltage	I _{OUT} = 50 μA	3.0	0.002	0.1	0.1	V	
			4.5	0.001	0.1	0.1		
			5.5	0.001	0.1	0.1		
	Maximum Input Leakage Current	V _{IN} = V _{IL} or V _{IH} 12mA	3.0		0.36	0.44	V	
			I _{OL} 24mA	4.5		0.36		0.44
			24mA	5.5		0.36		0.44
I _{IN}	Maximum Input Leakage Current	V _{IN} = V _{CC} or GND	5.5		±0.1	±1.0	μA	
I _{CC}	Maximum Quiescent Supply Current	V _{IN} = V _{CC} or GND	5.5		4.0	40	μA	

AC CHARACTERISTICS over full operating conditions

Symbol	Parameter	V _{CC} ±10% (V)	AC109				Unit
			TA = +25°C CL = 50 pF		TA = -40°C to +85°C CL = 50 pF		
			Min	Max	Min	Max	
f _{MAX}	Maximum Clock Frequency	3.3	125 150		100 125		MHz
t _{PLH}	Propagation Delay Clock to Output	3.3 5.0	4.0 2.5	13.5 10.0	3.5 2.0	16.0 10.5	ns
t _{PHL}	Propagation Delay Clock to Output	3.3 5.0	3.0 2.0	14.0 10.0	3.0 1.5	14.5 10.5	ns
t _{PLH}	Propagation Delay Reset or Set to Output	3.3 5.0	3.0 2.0	12.0 9.0	2.5 2.0	13.0 10.0	ns
t _{PHL}	Propagation Delay Reset or Set to Output	3.3 5.0	3.0 2.0	12.0 9.5	3.0 2.0	13.5 10.5	ns
t _s	Setup Time, HIGH or LOW Data Input to Clock	3.3 5.0	6.5 4.5		7.5 5.0		ns
t _h	Hold Time, HIGH or LOW Data Input to Clock	3.3 5.0	0 0.5		0 0.5		ns
t _w	Pulse Width Clock, Set or Reset	3.3 5.0	4.0 3.5		4.5 3.5		ns
t _{rec}	Recovery Time Set or Reset to Clock	3.3 5.0	0 0		0 0		ns

ACT — 109

DC ELECTRICAL CHARACTERISTICS

Symbol	Parameter	Conditions	V _{CC} (V)	ACT109			Unit
				TA = +25°C		TA = -40 to +85°C	
				Typ	Guaranteed Limits		
V _{IH}	Minimum High Level Input Voltage	V _{OUT} = 0.1V or V _{CC} - 0.1 V	4.5	1.5	2.0	2.0	V
			5.5	1.5	2.0	2.0	
V _{IL}	Maximum Low Level Input Voltage	V _{OUT} = 0.1V or V _{CC} - 0.1 V	4.5	1.5	0.8	0.8	V
			5.5	1.5	0.8	0.8	

109

DC ELECTRICAL CHARACTERISTICS(continued)

Symbol	Parameter	Conditions	V _{CC} (V)	ACT109			Unit
				T _A = +25°C		T _A = -40 to +85°C	
				Typ	Guaranteed Limits		
V _{OH}	Minimum High Level Output Voltage	I _{OUT} = -50 μA	4.5 5.5	4.49 5.49	4.4 5.4	4.4 5.4	V
		V _{IN} = V _{IL} or V _{IH} I _{OH} = -24mA -24 mA	4.5 5.5		3.86 4.86	3.76 4.76	V
V _{OL}	Maximum Low Level Output Voltage	I _{OUT} = 50 μA	4.5 5.5	0.001 0.001	0.1 0.1	0.1 0.1	V
		V _{IN} = V _{IL} or V _{IH} I _{OL} = 24mA 24 mA	4.5 5.5		0.36 0.36	0.44 0.44	V
I _{IN}	Maximum Input Leakage Current	V _{IN} = V _{CC} or GND	5.5		±0.1	±1.0	μA
ΔI _{CC} T	Additional Max I _{CC} /Input	V _{IN} = V _{CC} - 2.1 V	5.5	0.6		1.5	mA
I _{CC}	Maximum Quiescent Supply Current	V _{IN} = V _{CC} or GND	5.5		4.0	40	μA

AC CHARACTERISTICS over full operating conditions

Symbol	Parameter	V _{CC} ±10% (V)	ACT109				Unit
			T _A = +25°C C _L = 50 pF		T _A = -40°C to +85°C C _L = 50 pF		
			Min	Max	Min	Max	
f _{MAX}	Maximum Clock Frequency	5.0	145		125		MHz
t _{PLH}	Propagation Delay, Clock to Output	5.0	4.0	11.0	3.5	13.0	ns
t _{PHL}	Propagation Delay, Clock to Output	5.0	3.0	10.0	2.5	11.5	ns
t _{PLH}	Propagation Delay, Reset or Set to Output	5.0	2.5	9.5	2.0	10.5	ns
t _{PHL}	Propagation Delay Reset or Set to Output	5.0	2.5	10.0	2.0	11.5	ns
t _s	Setup Time, HIGH or LOW Data Input to Clock	5.0	2.0		2.5		ns
t _h	Hold Time, HIGH or LOW Data Input to Clock	5.0	2.0		2.0		ns
t _w	Pulse Width Clock, Set or Reset	5.0	5.0		6.0		ns
t _{rec}	Recovery Time Set or Reset to Clock	5.0	0		0		ns

109

SWITCHING WAVEFORMS

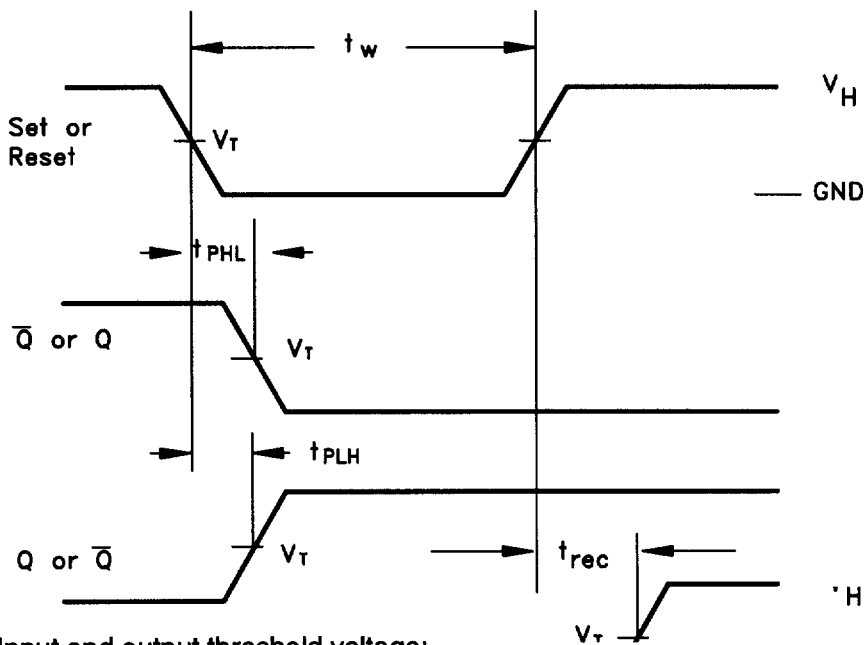
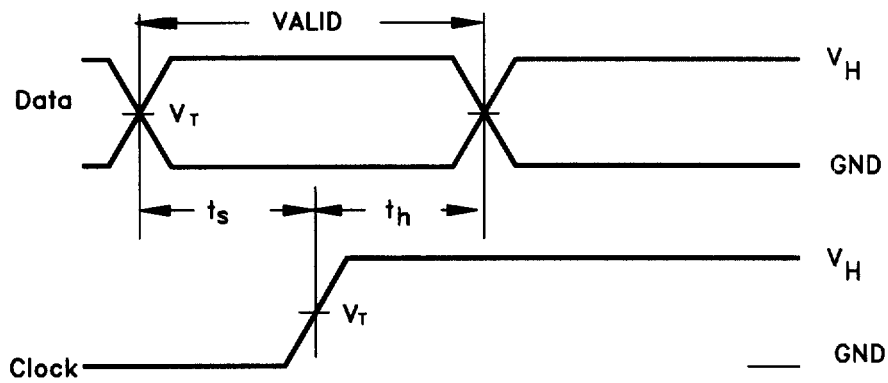
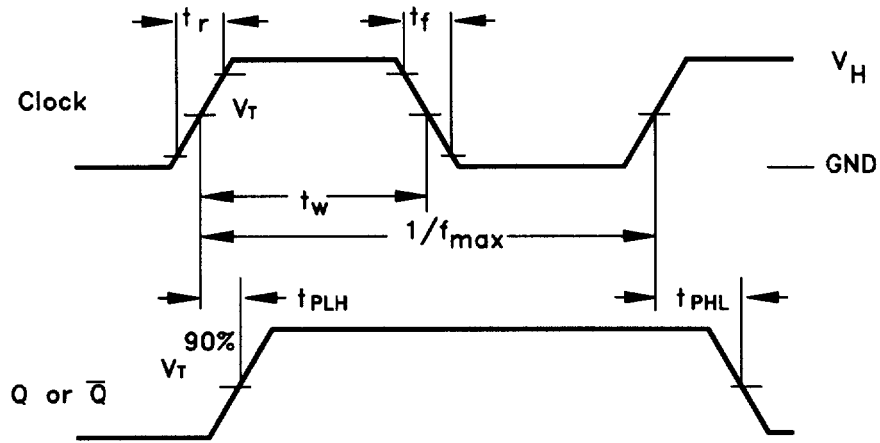

Input and output threshold voltage:
 $V_T = 50\% V_{cc}$ for AC; 1.5V for ACT
 $V_H = V_{cc}$ for AC, 3V for ACT