

4 Mb (512K x 8) ZEROPOWER SRAM

NOT FOR NEW DESIGN

- INTEGRATED LOW POWER SRAMs, POWER-FAIL CONTROL CIRCUIT and BATTERY
- CONVENTIONAL SRAM OPERATION; UNLIMITED WRITE CYCLES
- 5 YEARS of DATA RETENTION in the ABSENCE of POWER
- AUTOMATIC POWER-FAIL CHIP DESELECT and WRITE PROTECTION
- WRITE PROTECT VOLTAGES:
 - M48Z512: $4.5V \leq V_{PFD} \leq 4.75V$
 - M48Z512Y: $4.2V \leq V_{PFD} \leq 4.50V$
- BATTERY INTERNALLY ISOLATED UNTIL POWER IS APPLIED
- PIN and FUNCTION COMPATIBLE with JEDEC STANDARD 512K x 8 SRAMs
- **The M48Z512/512Y will be replaced shortly by the new version of this product (M48Z512A/512AY) which will maintain the same features and improve data retention to 10 years and speed grade of 70ns**

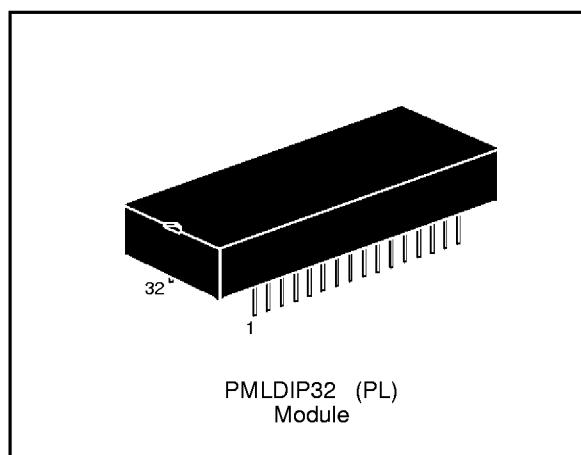
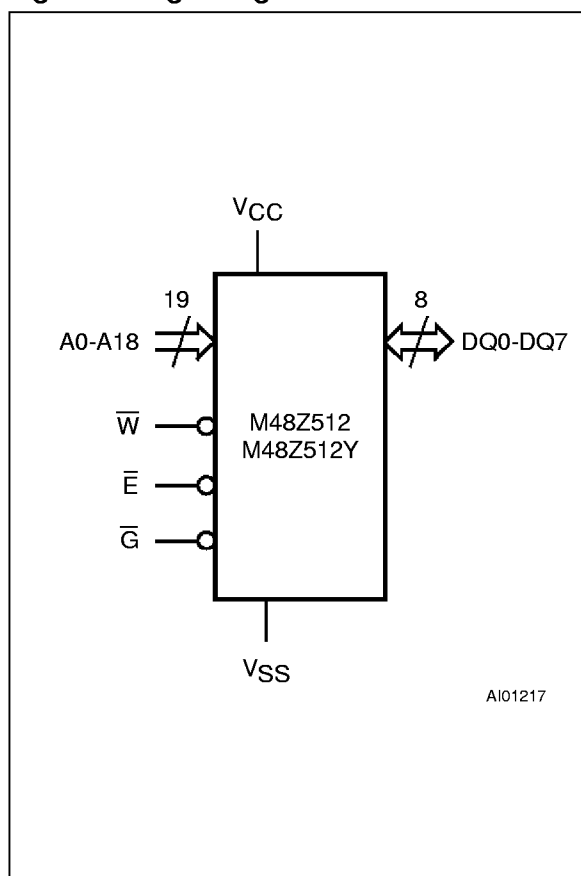

Figure 1. Logic Diagram



DESCRIPTION

The M48Z512/512Y 512K x 8 ZEROPOWER RAM is a non-volatile 4,194,304 bit Static RAM organized as 524,288 words by 8 bits. The device combines two internal lithium batteries and a full CMOS SRAMs in a plastic 32 pin DIP long Module.

Table 1. Signal Names

A0-A18	Address Inputs
DQ0-DQ7	Data Inputs / Outputs
\bar{E}	Chip Enable
\bar{G}	Output Enable
\bar{W}	Write Enable
V _{CC}	Supply Voltage
V _{SS}	Ground

Table 2. Absolute Maximum Ratings

Symbol	Parameter	Value	Unit
T _A	Ambient Operating Temperature	0 to 70	°C
T _{STG}	Storage Temperature (V _{CC} Off)	-40 to 70	°C
T _{BIAS}	Temperature Under Bias	-10 to 70	°C
T _{SLD}	Lead Soldering Temperature for 10 seconds	260	°C
V _{IO}	Input or Output Voltages	-0.3 to 7	V
V _{CC}	Supply Voltage	-0.3 to 7	V

Note: Stresses greater than those listed under "Absolute Maximum Ratings" may cause permanent damage to the device. This is a stress rating only and functional operation of the device at these or any other conditions above those indicated in the operational section of this specification is not implied. Exposure to the absolute maximum ratings conditions for extended periods of time may affect reliability.

CAUTION: Negative undershoots below -0.3 volts are not allowed on any pin while in the Battery Back-up mode.

Table 3. Operating Modes

Mode	V _{CC}	\bar{E}	\bar{G}	\bar{W}	DQ0-DQ7	Power
Deselect	4.75V to 5.5V or 4.5V to 5.5V	V _{IH}	X	X	High Z	Standby
Write		V _{IL}	X	V _{IL}	D _{IN}	Active
Read		V _{IL}	V _{IL}	V _{IH}	D _{OUT}	Active
Read		V _{IL}	V _{IH}	V _{IH}	High Z	Active
Deselect	V _{SO} to V _{PFD} (min)	X	X	X	High Z	CMOS Standby
Deselect	≤ V _{SO}	X	X	X	High Z	Battery Back-up Mode

Note: X = V_{IH} or V_{IL}

Figure 2. DIP Pin Connections

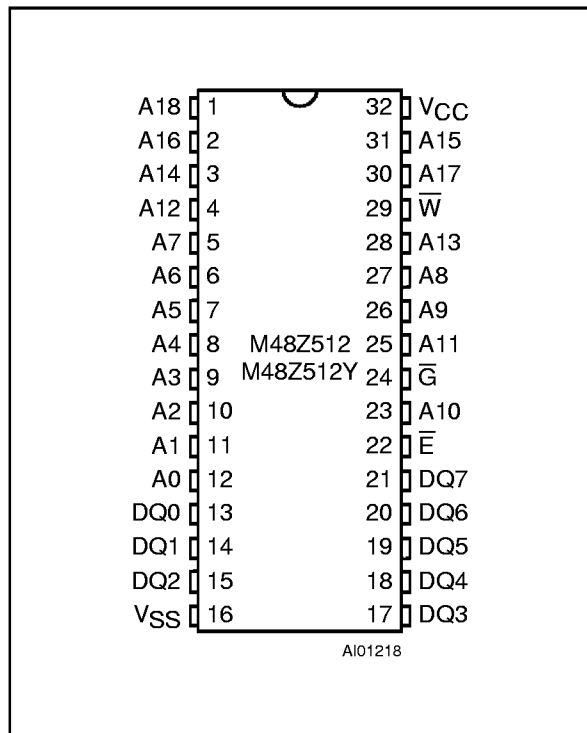

DESCRIPTION (cont'd)

The ZEROPOWER RAM directly replaces industry standard SRAMs. It also fits into many EPROM and EEPROM sockets, providing the nonvolatility of PROMs without any requirement for special write timing or limitations on the number of writes that can be performed.

The M48Z512/512Y has its own Power-fail Detect Circuit. The control circuitry constantly monitors the single 5V supply for an out of tolerance condition. When V_{CC} is out of tolerance, the circuit write protects the SRAM, providing a high degree of data security in the midst of unpredictable system operations brought on by low V_{CC}. As V_{CC} falls below approximately 3V, the control circuitry connects the batteries which sustain data until valid power returns.

READ MODE

The M48Z512/512Y is in the Read Mode whenever \bar{W} (Write Enable) is high and \bar{E} (Chip Enable) is low. The device architecture allows ripple-through access of data from eight of 4,194,304 locations in the static storage array. Thus, the unique address specified by the 19 Address Inputs defines which

Figure 3. Block Diagram

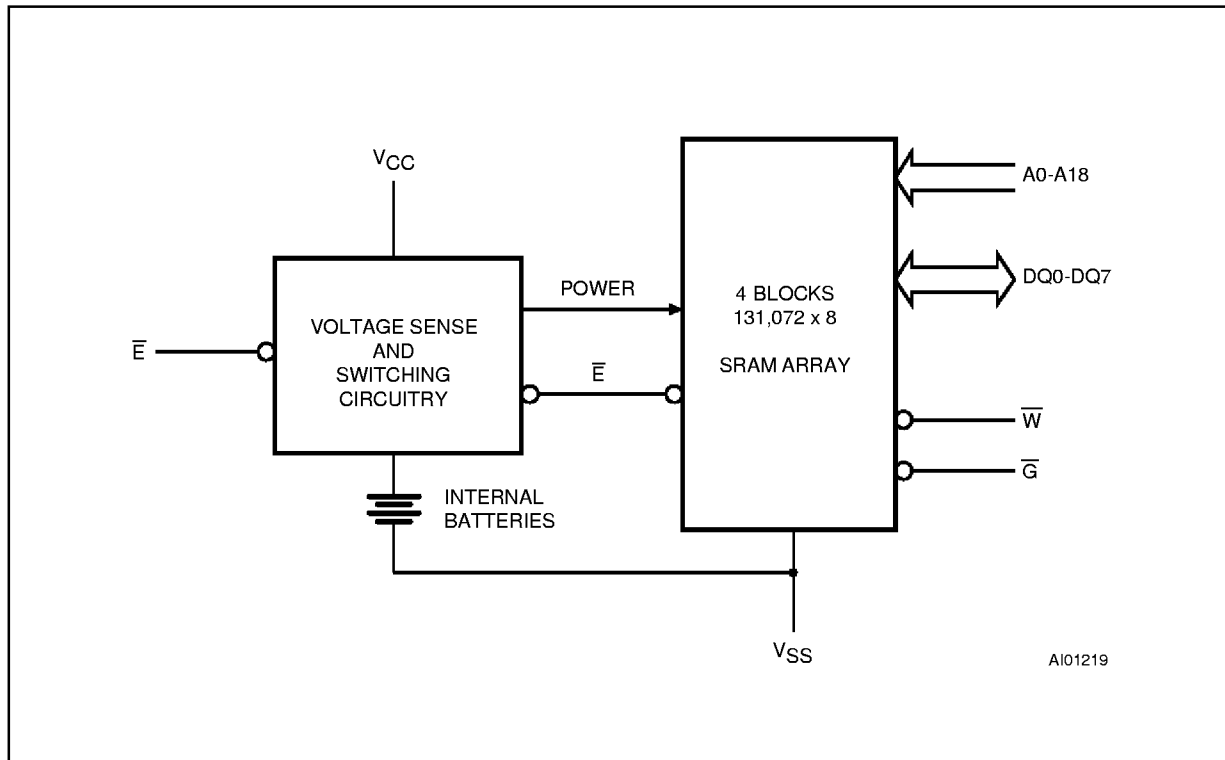

one of the 524,288 bytes of data is to be accessed. Valid data will be available at the Data I/O pins within t_{AVQV} (Address Access Time) after the last address input signal is stable, providing that the \bar{E} (Chip Enable) and \bar{G} (Output Enable) access times are also satisfied. If the \bar{E} and \bar{G} access times are not met, valid data will be available after the later of Chip Enable Access Time (t_{ELQV}) or Output Enable Access Time (t_{GLQV}).

The state of the eight three-state Data I/O signals is controlled by \bar{E} and \bar{G} . If the outputs are activated before t_{AVQV} , the data lines will be driven to an indeterminate state until t_{AVQV} . If the Address Inputs are changed while \bar{E} and \bar{G} remain low, output data will remain valid for t_{AXQX} (Output Data Hold Time) but will go indeterminate until the next Address Access.

WRITE MODE

The M48Z512/512Y is in the Write Mode whenever \bar{W} and \bar{E} are active. The start of a write is referenced from the latter occurring falling edge of \bar{W} or \bar{E} . A write is terminated by the earlier rising edge of \bar{W} or \bar{E} .

Table 4. AC Measurement Conditions

Input Rise and Fall Times	≤ 5ns
Input Pulse Voltages	0 to 3V
Input and Output Timing Ref. Voltages	1.5V

Note that Output Hi-Z is defined as the point where data is no longer driven.

Figure 4. AC Testing Load Circuit

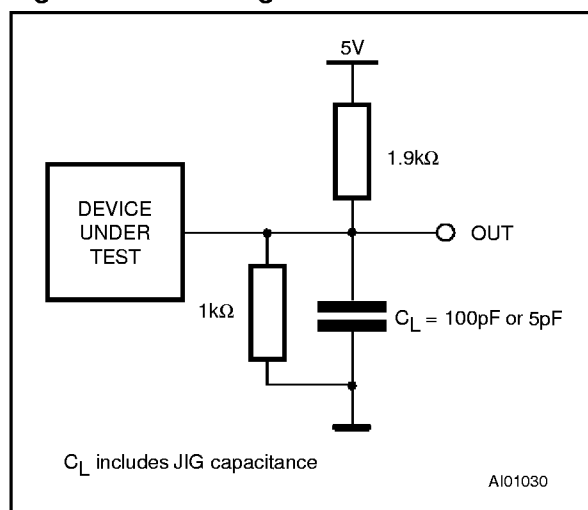

M48Z512, M48Z512Y

Table 5. Capacitance ^(1, 2)
($T_A = 25\text{ }^\circ\text{C}$, $f = 1\text{ MHz}$)

Symbol	Parameter	Test Condition	Min	Max	Unit
C_{IN}	Input Capacitance	$V_{IN} = 0V$		40	pF
C_{IO} ⁽³⁾	Input / Output Capacitance	$V_{OUT} = 0V$		40	pF

Notes: 1. Effective capacitance measured with power supply at 5V.
2. Sampled only, not 100% tested.
3. Outputs deselected

Table 6. DC Characteristics
($T_A = 0\text{ to }70\text{ }^\circ\text{C}$; $V_{CC} = 4.75V\text{ to }5.5V\text{ or }4.5V\text{ to }5.5V$)

Symbol	Parameter	Test Condition	Min	Max	Unit
I_{LI} ⁽¹⁾	Input Leakage Current	$0V \leq V_{IN} \leq V_{CC}$		± 4	μA
I_{LO} ⁽¹⁾	Output Leakage Current	$0V \leq V_{OUT} \leq V_{CC}$		± 4	μA
I_{CC}	Supply Current	$\bar{E} = V_{IL}$, Outputs open		115	mA
I_{CC1}	Supply Current (Standby) TTL	$\bar{E} = V_{IH}$		17	mA
I_{CC2}	Supply Current (Standby) CMOS	$\bar{E} \geq V_{CC} - 0.2V$		5	mA
V_{IL}	Input Low Voltage		-0.3	0.8	V
V_{IH}	Input High Voltage		2.2	$V_{CC} + 0.3$	V
V_{OL}	Output Low Voltage	$I_{OL} = 2.1mA$		0.4	V
V_{OH}	Output High Voltage	$I_{OH} = -1mA$	2.4		V

Note: 1. Outputs deselected.

Table 7. Power Down/Up Trip Points DC Characteristics ⁽¹⁾
($T_A = 0\text{ to }70\text{ }^\circ\text{C}$)

Symbol	Parameter	Min	Typ	Max	Unit
V_{PFD}	Power-fail Deselect Voltage (M48Z512)	4.5	4.6	4.75	V
V_{PFD}	Power-fail Deselect Voltage (M48Z512Y)	4.2	4.3	4.5	V
V_{SO}	Battery Back-up Switchover Voltage		3		V
t_{DR} ⁽²⁾	Data Retention Time	10			YEARS

Notes: 1. All voltages referenced to V_{SS} .
2. @ $25\text{ }^\circ\text{C}$

Table 8. Power Down/Up Mode AC Characteristics
($T_A = 0$ to 70°C)

Symbol	Parameter	Min	Max	Unit
$t_F^{(1)}$	$V_{\text{PFD}}(\text{max})$ to $V_{\text{PFD}}(\text{min})$ V_{CC} Fall Time	300		μs
$t_{\text{FB}}^{(2)}$	$V_{\text{PFD}}(\text{min})$ to V_{SO} V_{CC} Fall Time	10		μs
t_{WP}	Write Protect Time from $V_{\text{CC}} = V_{\text{PFD}}$	40	150	μs
t_{R}	V_{SO} to $V_{\text{PFD}}(\text{max})$ V_{CC} Rise Time	0		μs
t_{ER}	\bar{E} Recovery Time	40	120	ms

Notes: 1. $V_{\text{PFD}}(\text{max})$ to $V_{\text{PFD}}(\text{min})$ fall time of less than t_F may result in deselection/write protection not occurring until $200 \mu\text{s}$ after V_{CC} passes $V_{\text{PFD}}(\text{min})$.

2. $V_{\text{PFD}}(\text{min})$ to V_{SO} fall time of less than t_{FB} may cause corruption of RAM data.

Figure 5. Power Down/Up Mode AC Waveforms

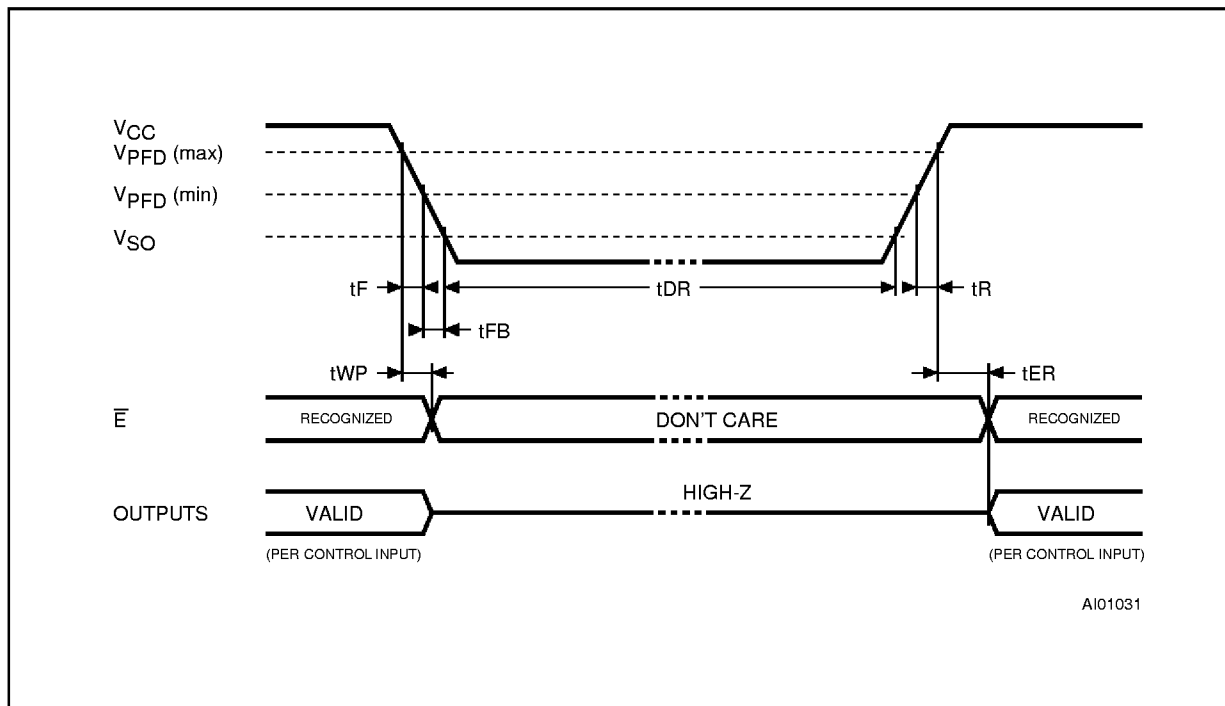

M48Z512, M48Z512Y

Table 9. Read Mode AC Characteristics
 ($T_A = 0$ to 70°C ; $V_{CC} = 4.75\text{V}$ to 5.5V or 4.5V to 5.5V)

Symbol	Parameter	M48Z512 / M48Z512Y				Unit
		-85		-120		
		Min	Max	Min	Max	
t_{AVAV}	Read Cycle Time	85		120		ns
$t_{AVQV}^{(1)}$	Address Valid to Output Valid		85		120	ns
$t_{ELQV}^{(1)}$	Chip Enable Low to Output Valid		85		120	ns
$t_{GLQV}^{(1)}$	Output Enable Low to Output Valid		45		60	ns
$t_{ELQX}^{(2)}$	Chip Enable Low to Output Transition	5		5		ns
$t_{GLQX}^{(2)}$	Output Enable Low to Output Transition	0		0		ns
$t_{EHQZ}^{(2)}$	Chip Enable High to Output Hi-Z		35		45	ns
$t_{GHQZ}^{(2)}$	Output Enable High to Output Hi-Z		25		35	ns
$t_{AXQX}^{(1)}$	Address Transition to Output Transition	5		5		ns

Notes: 1. $C_L = 100\text{pF}$ (see Figure 4).
 2. $C_L = 5\text{pF}$ (see Figure 4)

Figure 6. Address Controlled, Read Mode AC Waveforms

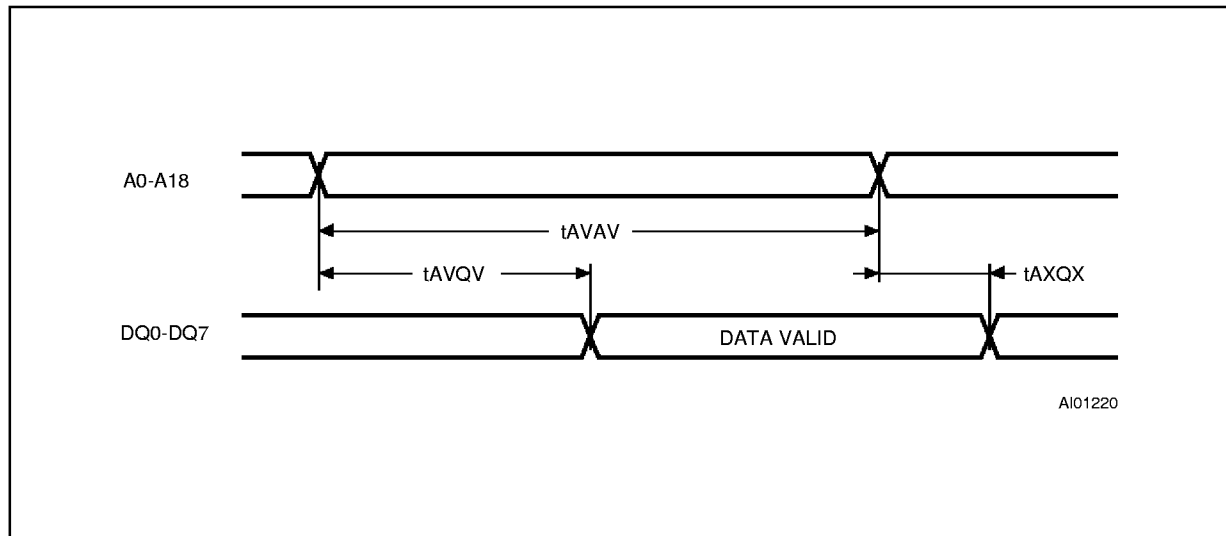

Note: Chip Enable (\bar{E}) and Output Enable (\bar{G}) = Low, Write Enable (\bar{W}) = High.

Figure 7. Chip Enable or Output Enable Controlled, Read Mode AC Waveforms

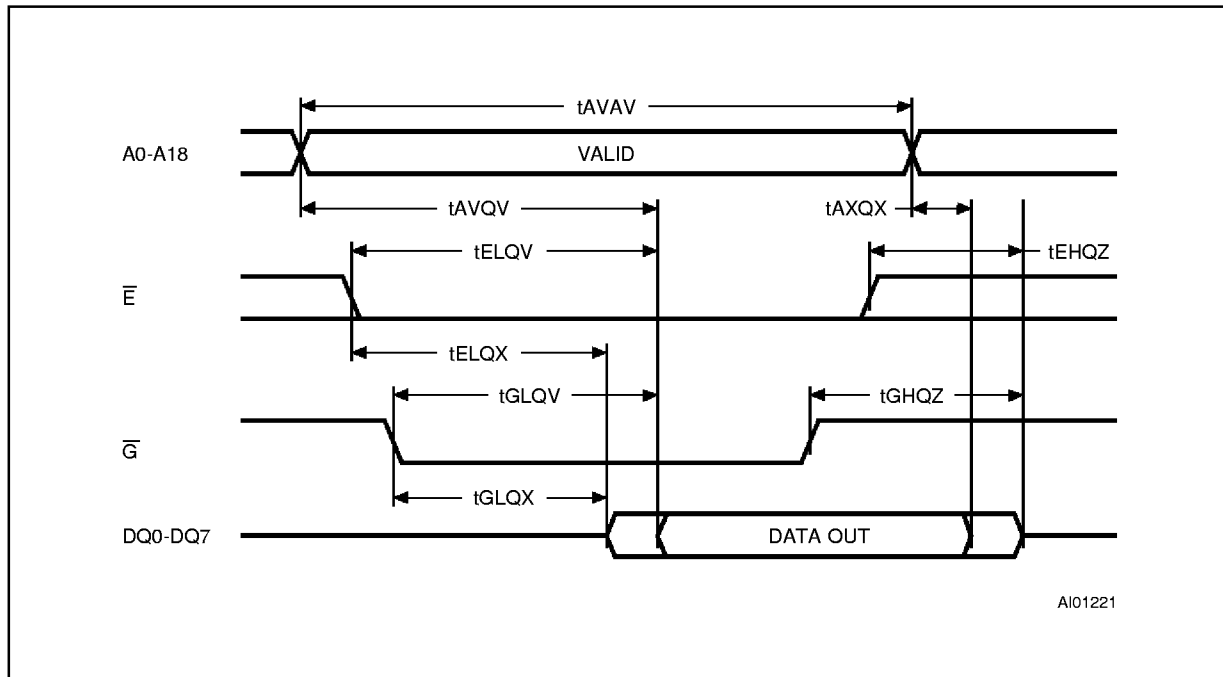

Note: Write Enable (\bar{W}) = High.

WRITE MODE (cont'd)

The addresses must be held valid throughout the cycle. \bar{E} or \bar{W} must return high for minimum of t_{EHAX} from \bar{E} or t_{WHAX} from \bar{W} prior to the initiation of another read or write cycle. Data-in must be valid t_{DVEH} or t_{WDHX} prior to the end of write and remain valid for t_{EHDX} or t_{WHDX} afterward. \bar{G} should be kept high during write cycles to avoid bus contention; although, if the output bus has been activated by a low on \bar{E} and \bar{G} , a low on \bar{W} will disable the outputs t_{WLQZ} after \bar{W} falls.

DATA RETENTION MODE

With valid V_{CC} applied, the M48Z512/512Y operates as a conventional BYTEWIDE™ static RAM. Should the supply voltage decay, the RAM will automatically power-fail deselect, write protecting

itself t_{WP} after V_{CC} falls below V_{PFD} . All outputs become high impedance, and all inputs are treated as "don't care."

If power fail detection occurs during a valid access, the memory cycle continues to completion. If the memory cycle fails to terminate within the time t_{WP} , write protection takes place. When V_{CC} drops below V_{SO} , the control circuit switches power to the internal energy source which preserves data.

The internal coin cells will maintain data in the M48Z512/512Y after the initial application of V_{CC} for an accumulated period of at least 5 years when V_{CC} is less than V_{SO} . As system power returns and V_{CC} rises above V_{SO} , the batteries are disconnected, and the power supply is switched to external V_{CC} . Write protection continues for t_{ER} after V_{CC} reaches V_{PFD} to allow for processor stabilization. After t_{ER} , normal RAM operation can resume.

M48Z512, M48Z512Y

Table 10. Write Mode AC Characteristics

($T_A = 0$ to 70°C ; $V_{CC} = 4.75\text{V}$ to 5.5V or 4.5V to 5.5V)

Symbol	Parameter	M48Z512 / M48Z512Y				Unit
		-85		-120		
		Min	Max	Min	Max	
t_{AVAV}	Write Cycle Time	85		120		ns
t_{AVWL}	Address Valid to Write Enable Low	0		0		ns
t_{AVEL}	Address Valid to Chip Enable Low	0		0		ns
t_{WLWH}	Write Enable Pulse Width	65		85		ns
t_{ELEH}	Chip Enable Low to Chip Enable High	75		100		ns
t_{WHAX}	Write Enable High to Address Transition	5		5		ns
t_{EHAX}	Chip Enable High to Address Transition	15		15		ns
t_{DVWH}	Input Valid to Write Enable High	35		45		ns
t_{DVEH}	Input Valid to Chip Enable High	35		45		ns
t_{WHDX}	Write Enable High to Input Transition	0		0		ns
t_{EHDX}	Chip Enable High to Input Transition	10		10		ns
$t_{WLQZ}^{(1,2)}$	Write Enable Low to Output Hi-Z		30		40	ns
t_{AVWH}	Address Valid to Write Enable High	75		100		ns
t_{AVEH}	Address Valid to Chip Enable High	75		100		ns
$t_{WHQX}^{(1,2)}$	Write Enable High to Output Transition	5		5		ns

Notes: 1. $C_L = 5\text{pF}$ (see Figure 4).

2. If \overline{E} goes low simultaneously with \overline{W} going low, the outputs remain in the high-impedance state.

Figure 8. Write Enable Controlled, Write AC Waveforms

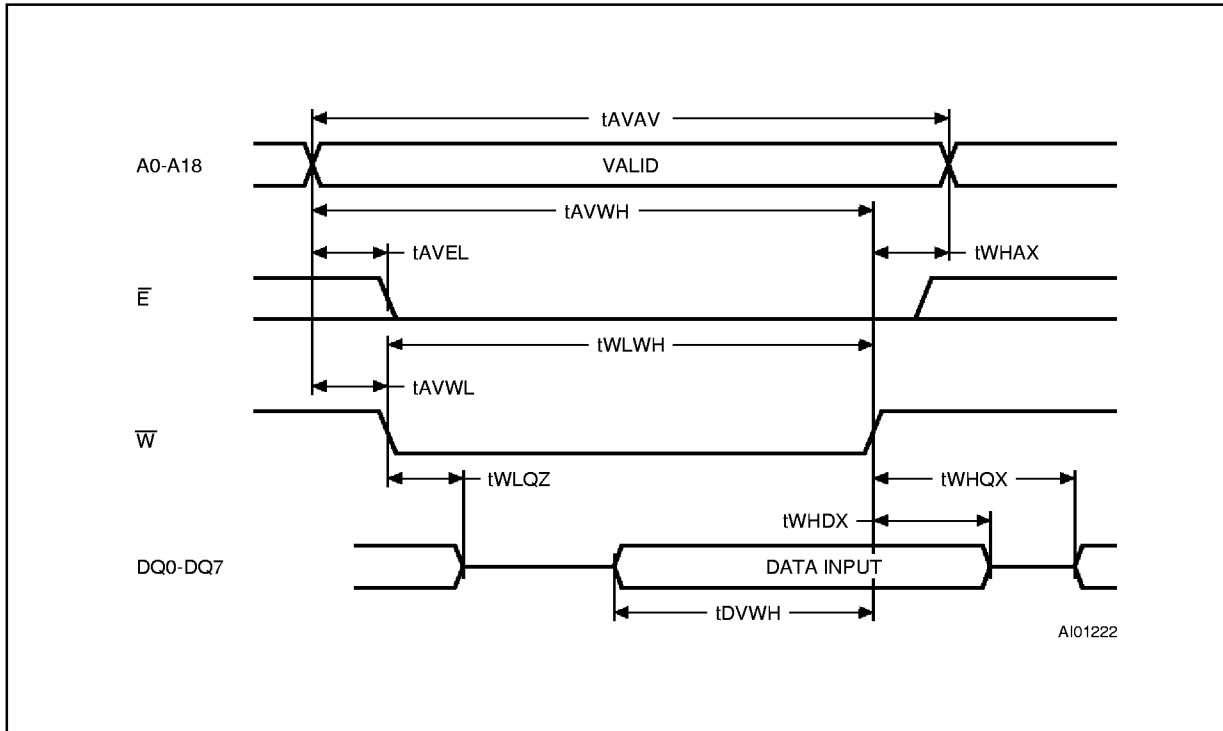

Note: Output Enable (\overline{G}) = High.

Figure 9. Chip Enable Controlled, Write AC Waveforms

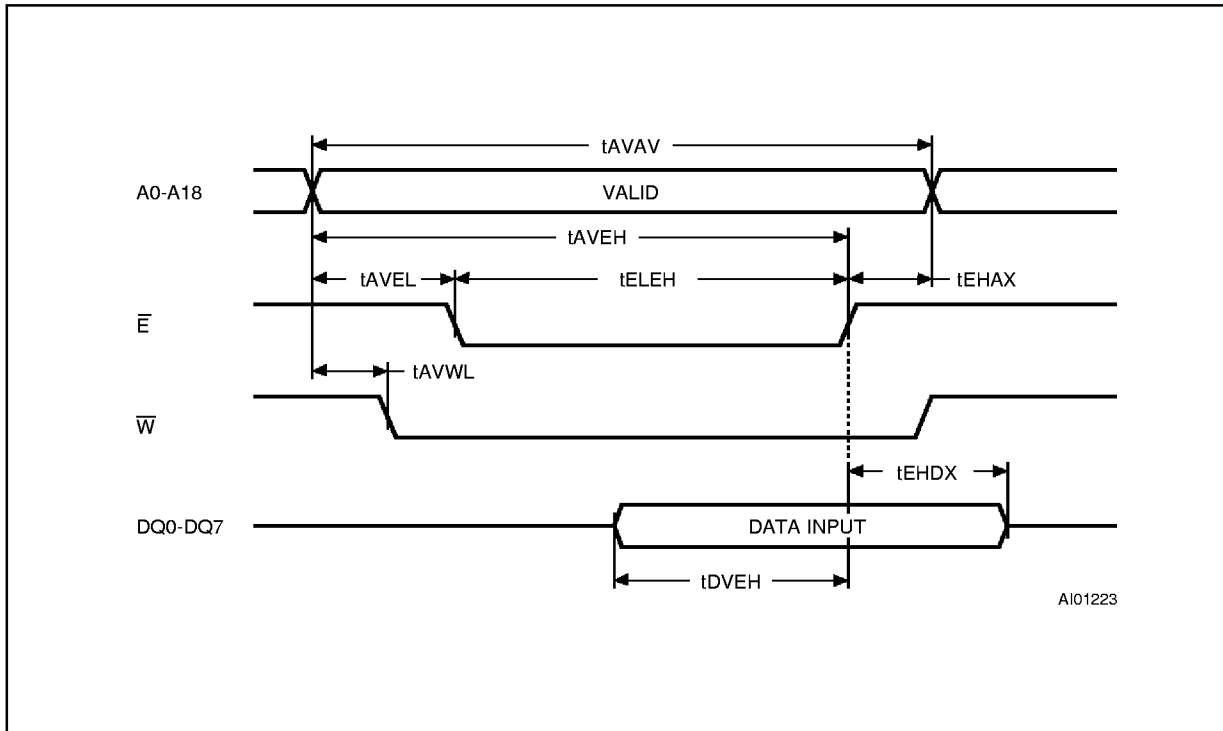

Note: Output Enable (\overline{G}) = High.

M48Z512, M48Z512Y

ORDERING INFORMATION SCHEME

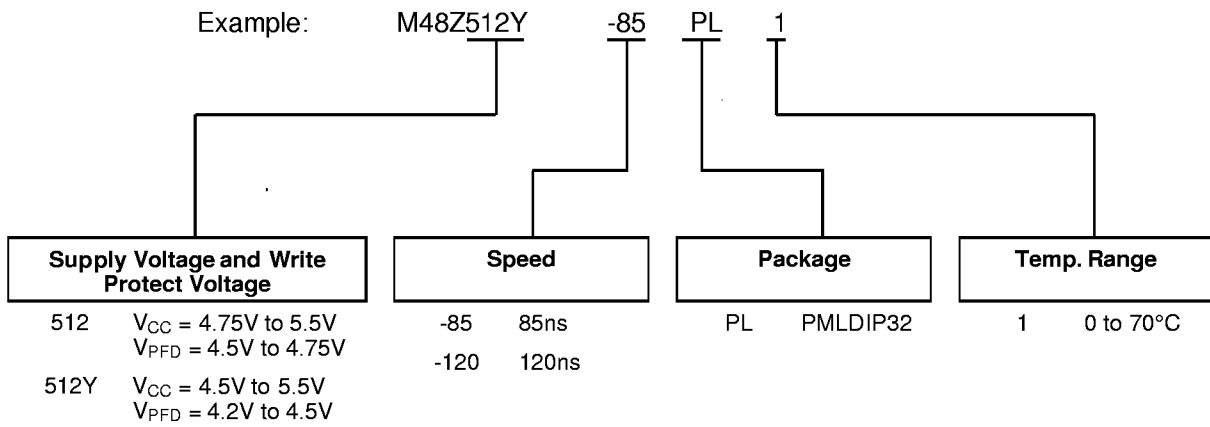

The M48Z512/512Y will be replaced shortly by the new version of this product (M48Z512A/512AY) which will maintain the same features and improve data retention to 10 years and speed grade of 70ns.

For a list of available options (Speed, etc...) or for further information or any aspect of this device, please contact the SGS-THOMSON Sales Office nearest to you.

PMLDIP32 - 32 pin Plastic DIP Long Module

Symb	mm			inches		
	Typ	Min	Max	Typ	Min	Max
A		9.27	9.52		0.365	0.375
A1		0.38	–		0.015	–
B		0.43	0.59		0.017	0.023
C		0.20	0.33		0.008	0.013
D		52.58	53.34		2.070	2.100
E		18.03	18.80		0.710	0.740
e1		2.29	2.79		0.090	0.110
e3		34.29	41.91		1.350	1.650
eA		14.99	16.00		0.590	0.630
L		3.05	3.81		0.120	0.150
S		6.99	7.87		0.275	0.310
N		32			32	

PMLDIP32

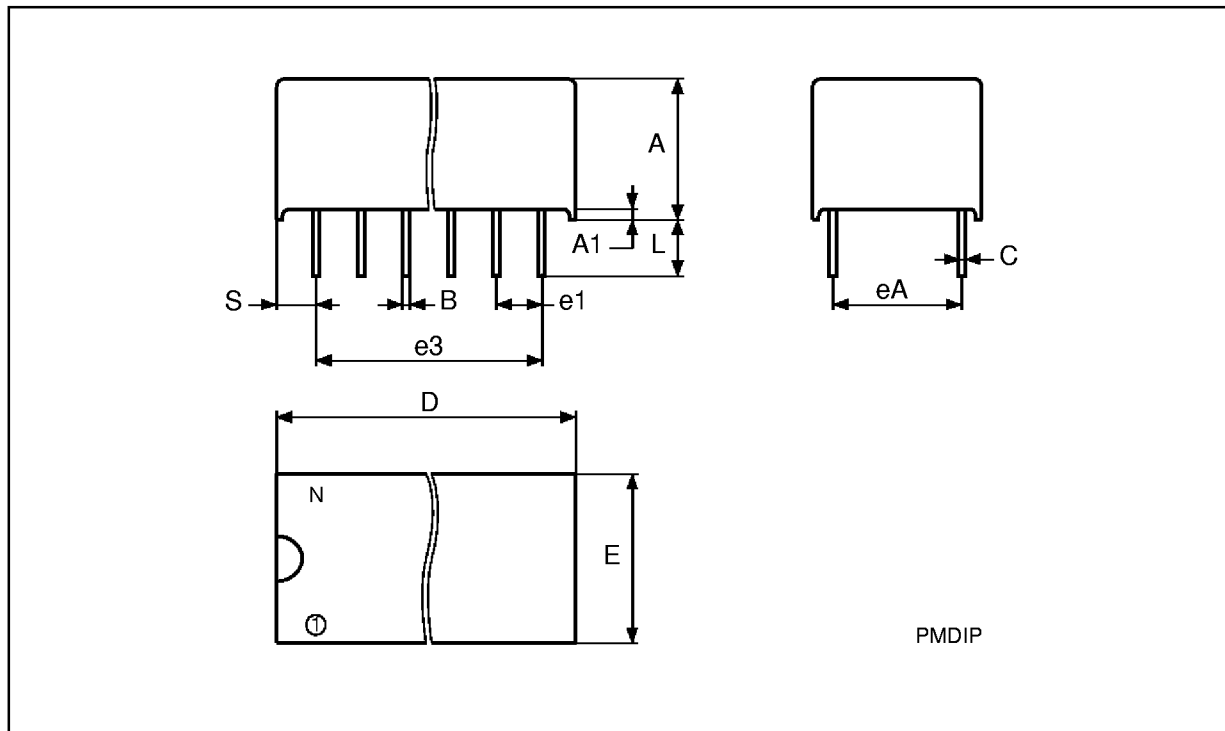

Drawing is not to scale.