



H78XX Series

3-Terminal Positive Voltage Regulators

Description

The H78XX series can provide local on-card regulation, eliminating the distribution problems associated with single point regulation. Each employs internal current limiting, thermal shut-down and safe operating area protection, making it essentially indestructible. If adequate heat sinking is provided, they can deliver over 1A output current. Although designed primarily as fixed voltage regulators, these devices can be used with external components to obtain adjustable voltages and currents.

Features

- Output Current In Excess of 1A
- Output Voltages of 5V, 6V, 8V, 9V, 12V
- Internal Short-Circuit Current Limiting & Thermal Overload Protection
- Guaranteed In Extended Temperature Range

Absolute Maximum Ratings (T_A=25°C)

Characteristic	Symbol	Rating	Unit
Input Voltage	V _{IN}	40	V
Power Dissipation	P _D	Internally limited ^(Note)	
Operating Temperature	T _{opr}	-40 to 125	°C
Storage Temperature	T _{stg}	-55 to 150	°C
Junction Temperature	T _j	150	°C

Note: (1)T_A=25°C, TO-251: 1W, TO-252: 1W, SOT-82: 2.1W, TO-220AB: 2.7W
 (2)T_C=25°C, All package: 10W

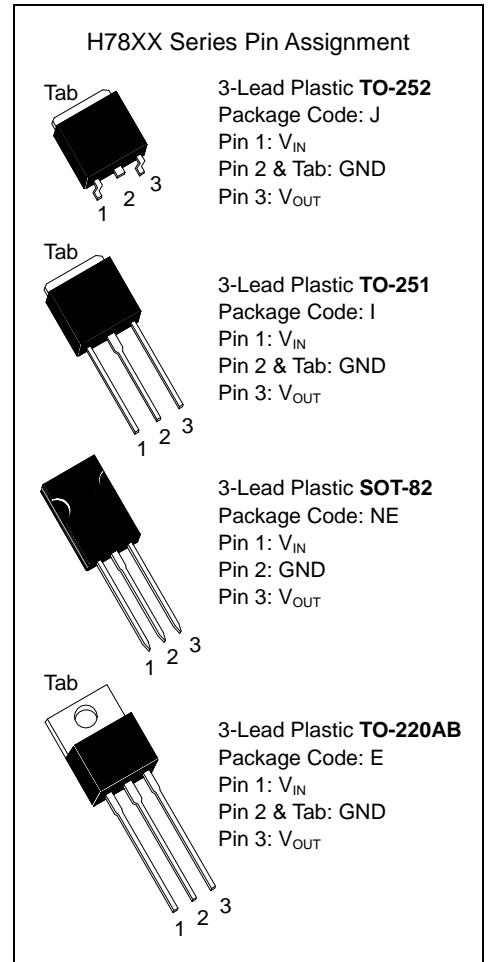

Thermal Data

Characteristic	Symbol	TO-252	TO-251	SOT-82	TO-220AB	Unit
Thermal Resistance Junction-Case	R _{th(j-c)}	12.5	12.5	12.5	12.5	°C/W
Thermal Resistance Junction-Ambient	R _{th(j-a)}	125	125	60	47	°C/W

Schematic Diagram & Equivalent Circuit

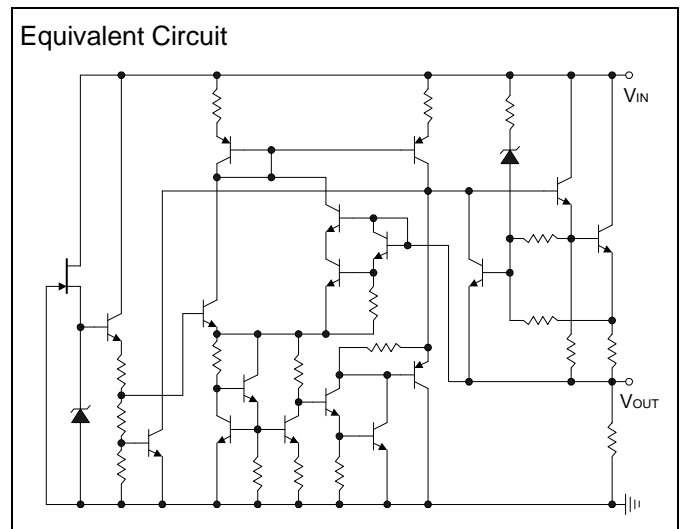
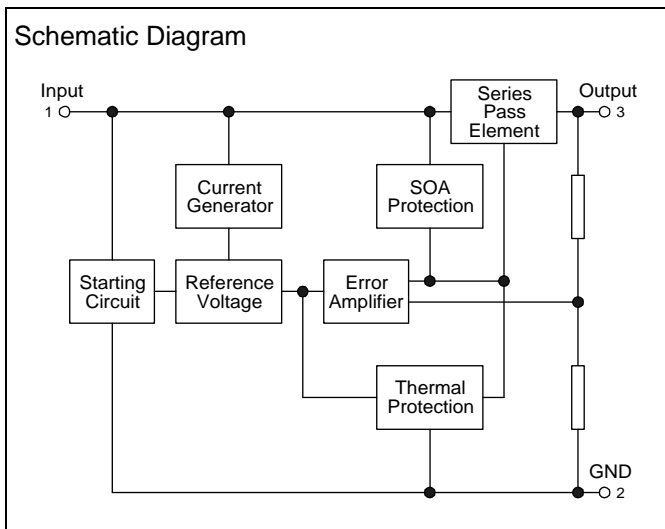



H7805 Series Electrical Characteristics

$V_{IN}=10V$, $I_{OUT}=500mA$, $C_{IN}=0.33\mu F$, $C_{OUT}=0.1\mu F$, $-40^{\circ}C \leq T_J \leq 125^{\circ}C$ (unless otherwise specified)

Symbol	Parameter	Conditions	H7805AJ/AI/ANE/AE			Units
			Min	Typ	Max	
V_O	Output Voltage	$T_J=25^{\circ}C$, $I_{OUT}=500mA$	4.85	5	5.15	V
		$5mA \leq I_{OUT} \leq 1A$	4.85	5	5.15	
		$7V \leq V_{IN} \leq 25V$, $P_{OUT} \leq 15W$				
ΔV_O	Line Regulation	$T_J=25^{\circ}C$, $7V \leq V_{IN} \leq 25V$	-	3	50	mV
		$T_J=25^{\circ}C$, $8V \leq V_{IN} \leq 12V$	-	1	25	
ΔV_O	Load Regulation	$T_J=25^{\circ}C$, $5mA \leq I_{OUT} \leq 1A$	-	15	100	mV
		$T_J=25^{\circ}C$, $250mA \leq I_{OUT} \leq 750mA$	-	5	50	
I_B	Quiescent Current	$I_{OUT}=5mA$, $T_J=25^{\circ}C$	-	3.9	8	mA
ΔI_B	Quiescent Current Change	$I_{OUT}=500mA$, $7V \leq V_{IN} \leq 25V$, $T_J=25^{\circ}C$	-	-	1.3	mA
		$5mA \leq I_{OUT} \leq 1A$, $V_{IN}=10V$, $T_J=25^{\circ}C$	-	-	0.5	
eN	Output Noise Voltage	$B=10Hz \sim 100KHz$, $I_{OUT}=50mA$, $T_J=25^{\circ}C$	-	50	-	$\mu V/V_O$
RR	Ripple Rejection	$10V \leq V_{IN} \leq 18V$, $f=120Hz$, $I_{OUT}=50mA$, $T_J=25^{\circ}C$	57	73	-	dB
V_D	Dropout Voltage	$T_J=25^{\circ}C$, $I_{OUT}=1A$	-	2	2.5	V
R_O	Output Resistance	$f=1KHz$	-	17	-	$m\Omega$
I_{SC}	Short Circuit Current	$T_J=25^{\circ}C$	-	2.3	2.8	A
$\Delta V_O/\Delta T$	Output Voltage Drift	$-40^{\circ}C \leq T_J \leq 125^{\circ}C$	-	-	0.6	$mV/^{\circ}C$

Symbol	Parameter	Conditions	H7805BJ/BI/BNE/BE			Units
			Min	Typ	Max	
V_O	Output Voltage	$T_J=25^{\circ}C$, $I_{OUT}=500mA$	4.75	5	5.25	V
		$5mA \leq I_{OUT} \leq 1A$	4.75	5	5.25	
		$7V \leq V_{IN} \leq 25V$, $P_{OUT} \leq 15W$				
ΔV_O	Line Regulation	$T_J=25^{\circ}C$, $7V \leq V_{IN} \leq 25V$	-	3	100	mV
		$T_J=25^{\circ}C$, $8V \leq V_{IN} \leq 12V$	-	1	50	
ΔV_O	Load Regulation	$T_J=25^{\circ}C$, $5mA \leq I_{OUT} \leq 1A$	-	15	100	mV
		$T_J=25^{\circ}C$, $250mA \leq I_{OUT} \leq 750mA$	-	5	50	
I_B	Quiescent Current	$I_{OUT}=5mA$, $T_J=25^{\circ}C$	-	3.9	8	mA
ΔI_B	Quiescent Current Change	$I_{OUT}=500mA$, $7V \leq V_{IN} \leq 25V$, $T_J=25^{\circ}C$	-	-	1.3	mA
		$5mA \leq I_{OUT} \leq 1A$, $V_{IN}=10V$, $T_J=25^{\circ}C$	-	-	0.5	
eN	Output Noise Voltage	$B=10Hz \sim 100KHz$, $I_{OUT}=50mA$, $T_J=25^{\circ}C$	-	50	-	$\mu V/V_O$
RR	Ripple Rejection	$10V \leq V_{IN} \leq 18V$, $f=120Hz$, $I_{OUT}=50mA$, $T_J=25^{\circ}C$	57	73	-	dB
V_D	Dropout Voltage	$T_J=25^{\circ}C$, $I_{OUT}=1A$	-	2	2.5	V
R_O	Output Resistance	$f=1KHz$	-	17	-	$m\Omega$
I_{SC}	Short Circuit Current	$T_J=25^{\circ}C$	-	2.3	2.8	A
$\Delta V_O/\Delta T$	Output Voltage Drift	$-40^{\circ}C \leq T_J \leq 125^{\circ}C$	-	-	0.6	$mV/^{\circ}C$



H7806 Series Electrical Characteristics

$V_{IN}=11V$, $I_{OUT}=500mA$, $C_{IN}=0.33\mu F$, $C_{OUT}=0.1\mu F$, $-40^{\circ}C \leq T_J \leq 125^{\circ}C$ (unless otherwise specified)

Symbol	Parameter	Conditions	H7806AJ/AI/ANE/AE			Units
			Min	Typ	Max	
V_O	Output Voltage	$T_J=25^{\circ}C$, $I_{OUT}=500mA$	5.82	6	6.18	V
		$5mA \leq I_{OUT} \leq 1A$	5.82	6	6.18	
		$8V \leq V_{IN} \leq 25V$, $P_{OUT} \leq 15W$				
ΔV_O	Line Regulation	$T_J=25^{\circ}C$, $8V \leq V_{IN} \leq 25V$	-	3	60	mV
		$T_J=25^{\circ}C$, $9V \leq V_{IN} \leq 13V$	-	1	25	
ΔV_O	Load Regulation	$T_J=25^{\circ}C$, $5mA \leq I_{OUT} \leq 1A$	-	15	100	mV
		$T_J=25^{\circ}C$, $250mA \leq I_{OUT} \leq 750mA$	-	5	50	
I_B	Quiescent Current	$I_{OUT}=5mA$, $T_J=25^{\circ}C$	-	3.9	8	mA
ΔI_B	Quiescent Current Change	$I_{OUT}=500mA$, $9V \leq V_{IN} \leq 25V$, $T_J=25^{\circ}C$	-	-	1.3	mA
		$5mA \leq I_{OUT} \leq 1A$, $V_{IN}=11V$, $T_J=25^{\circ}C$	-	-	0.5	
eN	Output Noise Voltage	$B=10Hz \sim 100KHz$, $I_{OUT}=50mA$, $T_J=25^{\circ}C$	-	-	55	$\mu V/V_O$
RR	Ripple Rejection	$11V \leq V_{IN} \leq 19V$, $f=120Hz$, $I_{OUT}=50mA$, $T_J=25^{\circ}C$	56	72	-	dB
V_D	Dropout Voltage	$T_J=25^{\circ}C$, $I_{OUT}=1A$	-	2	2.5	V
R_O	Output Resistance	$f=1KHz$	-	17	-	$m\Omega$
I_{SC}	Short Circuit Current	$V_{IN}=45V$, $T_J=25^{\circ}C$	-	2.3	2.8	A
$\Delta V_O/\Delta T$	Output Voltage Drift	$-40^{\circ}C \leq T_J \leq 125^{\circ}C$	-	-	0.7	$mV/^{\circ}C$

Symbol	Parameter	Conditions	H7806BJ/BI/BNE/BE			Units
			Min	Typ	Max	
V_O	Output Voltage	$T_J=25^{\circ}C$, $I_{OUT}=500mA$	5.7	6	6.3	V
		$5mA \leq I_{OUT} \leq 1A$	5.7	6	6.3	
		$8V \leq V_{IN} \leq 25V$, $P_{OUT} \leq 15W$				
ΔV_O	Line Regulation	$T_J=25^{\circ}C$, $8V \leq V_{IN} \leq 25V$	-	3	120	mV
		$T_J=25^{\circ}C$, $9V \leq V_{IN} \leq 13V$	-	1	60	
ΔV_O	Load Regulation	$T_J=25^{\circ}C$, $5mA \leq I_{OUT} \leq 1A$	-	15	120	mV
		$T_J=25^{\circ}C$, $250mA \leq I_{OUT} \leq 750mA$	-	5	60	
I_B	Quiescent Current	$I_{OUT}=5mA$, $T_J=25^{\circ}C$	-	3.9	8	mA
ΔI_B	Quiescent Current Change	$I_{OUT}=500mA$, $9V \leq V_{IN} \leq 25V$, $T_J=25^{\circ}C$	-	-	1.3	mA
		$5mA \leq I_{OUT} \leq 1A$, $V_{IN}=11V$, $T_J=25^{\circ}C$	-	-	0.5	
eN	Output Noise Voltage	$B=10Hz \sim 100KHz$, $I_{OUT}=50mA$, $T_J=25^{\circ}C$	-	-	55	$\mu V/V_O$
RR	Ripple Rejection	$11V \leq V_{IN} \leq 19V$, $f=120Hz$, $I_{OUT}=50mA$, $T_J=25^{\circ}C$	56	72	-	dB
V_D	Dropout Voltage	$T_J=25^{\circ}C$, $I_{OUT}=1A$	-	2	2.5	V
R_O	Output Resistance	$f=1KHz$	-	17	-	$m\Omega$
I_{SC}	Short Circuit Current	$V_{IN}=45V$, $T_J=25^{\circ}C$	-	2.3	2.8	A
$\Delta V_O/\Delta T$	Output Voltage Drift	$-40^{\circ}C \leq T_J \leq 125^{\circ}C$	-	-	0.7	$mV/^{\circ}C$



H7808 Series Electrical Characteristics

$V_{IN}=14V$, $I_{OUT}=500mA$, $C_{IN}=0.33\mu F$, $C_{OUT}=0.1\mu F$, $-40^{\circ}C \leq T_J \leq 125^{\circ}C$ (unless otherwise specified)

Symbol	Parameter	Conditions	H7808AJ/AI/ANE/AE			Units
			Min	Typ	Max	
V_O	Output Voltage	$T_J=25^{\circ}C$, $I_{OUT}=500mA$	7.76	8	8.24	V
		$5mA \leq I_{OUT} \leq 1A$	7.76	8	8.24	
		$10V \leq V_{IN} \leq 25V$, $P_{OUT} \leq 15W$				
ΔV_O	Line Regulation	$T_J=25^{\circ}C$, $10.5V \leq V_{IN} \leq 25V$	-	3	80	mV
		$T_J=25^{\circ}C$, $11V \leq V_{IN} \leq 17V$	-	1	40	
ΔV_O	Load Regulation	$T_J=25^{\circ}C$, $5mA \leq I_{OUT} \leq 1A$	-	15	100	mV
		$T_J=25^{\circ}C$, $250mA \leq I_{OUT} \leq 750mA$	-	5	50	
I_B	Quiescent Current	$I_{OUT}=5mA$, $T_J=25^{\circ}C$	-	3.9	8	mA
ΔI_B	Quiescent Current Change	$I_{OUT}=500mA$, $10.5V \leq V_{IN} \leq 25V$, $T_J=25^{\circ}C$	-	-	1.3	mA
		$5mA \leq I_{OUT} \leq 1A$, $V_{IN}=14V$, $T_J=25^{\circ}C$	-	-	0.5	
eN	Output Noise Voltage	$B=10Hz \sim 100KHz$, $I_{OUT}=50mA$, $T_J=25^{\circ}C$	-	-	70	$\mu V/V_O$
RR	Ripple Rejection	$14V \leq V_{IN} \leq 21.5V$, $f=120Hz$, $I_{OUT}=50mA$, $T_J=25^{\circ}C$	53	69	-	dB
V_D	Dropout Voltage	$T_J=25^{\circ}C$, $I_{OUT}=1A$	-	2	2.5	V
R_O	Output Resistance	$f=1KHz$	-	17	-	$m\Omega$
I_{SC}	Short Circuit Current	$T_J=25^{\circ}C$	-	2.3	2.8	A
$\Delta V_O/\Delta T$	Output Voltage Drift	$-40^{\circ}C \leq T_J \leq 125^{\circ}C$	-	-	1	$mV/^{\circ}C$

Symbol	Parameter	Conditions	H7808BJ/BI/BNE/BE			Units
			Min	Typ	Max	
V_O	Output Voltage	$T_J=25^{\circ}C$, $I_{OUT}=500mA$	7.6	8	8.4	V
		$5mA \leq I_{OUT} \leq 1A$	7.6	8	8.4	
		$10V \leq V_{IN} \leq 25V$, $P_{OUT} \leq 15W$				
ΔV_O	Line Regulation	$T_J=25^{\circ}C$, $10.5V \leq V_{IN} \leq 25V$	-	3	160	mV
		$T_J=25^{\circ}C$, $11V \leq V_{IN} \leq 17V$	-	1	80	
ΔV_O	Load Regulation	$T_J=25^{\circ}C$, $5mA \leq I_{OUT} \leq 1A$	-	15	160	mV
		$T_J=25^{\circ}C$, $250mA \leq I_{OUT} \leq 750mA$	-	5	80	
I_B	Quiescent Current	$I_{OUT}=5mA$, $T_J=25^{\circ}C$	-	3.9	8	mA
ΔI_B	Quiescent Current Change	$I_{OUT}=500mA$, $10.5V \leq V_{IN} \leq 25V$, $T_J=25^{\circ}C$	-	-	1.3	mA
		$5mA \leq I_{OUT} \leq 1A$, $V_{IN}=14V$, $T_J=25^{\circ}C$	-	-	0.5	
eN	Output Noise Voltage	$B=10Hz \sim 100KHz$, $I_{OUT}=50mA$, $T_J=25^{\circ}C$	-	-	70	$\mu V/V_O$
RR	Ripple Rejection	$14V \leq V_{IN} \leq 21.5V$, $f=120Hz$, $I_{OUT}=50mA$, $T_J=25^{\circ}C$	53	69	-	dB
V_D	Dropout Voltage	$T_J=25^{\circ}C$, $I_{OUT}=1A$	-	2	2.5	V
R_O	Output Resistance	$f=1KHz$	-	17	-	$m\Omega$
I_{SC}	Short Circuit Current	$T_J=25^{\circ}C$	-	2.3	2.8	A
$\Delta V_O/\Delta T$	Output Voltage Drift	$-40^{\circ}C \leq T_J \leq 125^{\circ}C$	-	-	1	$mV/^{\circ}C$



H7809 Series Electrical Characteristics

$V_{IN}=15V$, $I_{OUT}=500mA$, $C_{IN}=0.33\mu F$, $C_{OUT}=0.1\mu F$, $-40^{\circ}C \leq T_J \leq 125^{\circ}C$ (unless otherwise specified)

Symbol	Parameter	Conditions	H7809AJ/AI/ANE/AE			Units
			Min	Typ	Max	
V_O	Output Voltage	$T_J=25^{\circ}C$, $I_{OUT}=500mA$	8.73	9	9.27	V
		$5mA \leq I_{OUT} \leq 1A$	8.73	9	9.27	
		$11V \leq V_{IN} \leq 25V$, $P_{OUT} \leq 15W$				
ΔV_O	Line Regulation	$T_J=25^{\circ}C$, $11.5V \leq V_{IN} \leq 25V$	-	3	90	mV
		$T_J=25^{\circ}C$, $13V \leq V_{IN} \leq 19V$	-	1	45	
ΔV_O	Load Regulation	$T_J=25^{\circ}C$, $5mA \leq I_{OUT} \leq 1A$	-	15	100	mV
		$T_J=25^{\circ}C$, $250mA \leq I_{OUT} \leq 750mA$	-	5	50	
I_B	Quiescent Current	$I_{OUT}=5mA$, $T_J=25^{\circ}C$	-	3.9	8	mA
ΔI_B	Quiescent Current Change	$I_{OUT}=500mA$, $11.5V \leq V_{IN} \leq 26V$, $T_J=25^{\circ}C$	-	-	1.3	mA
		$5mA \leq I_{OUT} \leq 1A$, $V_{IN}=15V$, $T_J=25^{\circ}C$	-	-	0.5	
eN	Output Noise Voltage	$B=10Hz \sim 100KHz$, $I_{OUT}=50mA$, $T_J=25^{\circ}C$	-	-	75	$\mu V/V_O$
RR	Ripple Rejection	$15V \leq V_{IN} \leq 22.5V$, $f=120Hz$, $I_{OUT}=50mA$, $T_J=25^{\circ}C$	51	67	-	dB
V_D	Dropout Voltage	$T_J=25^{\circ}C$, $I_{OUT}=1A$	-	2	2.5	V
R_O	Output Resistance	$f=1KHz$	-	17	-	$m\Omega$
I_{SC}	Short Circuit Current	$T_J=25^{\circ}C$	-	2.3	2.8	A
$\Delta V_O/\Delta T$	Output Voltage Drift	$-40^{\circ}C \leq T_J \leq 125^{\circ}C$	-	-	1.1	$mV/^{\circ}C$

Symbol	Parameter	Conditions	H7809BJ/BI/BNE/BE			Units
			Min	Typ	Max	
V_O	Output Voltage	$T_J=25^{\circ}C$, $I_{OUT}=500mA$	8.55	9	9.45	V
		$5mA \leq I_{OUT} \leq 1A$	8.55	9	9.45	
		$11V \leq V_{IN} \leq 25V$, $P_{OUT} \leq 15W$				
ΔV_O	Line Regulation	$T_J=25^{\circ}C$, $11.5V \leq V_{IN} \leq 25V$	-	3	180	mV
		$T_J=25^{\circ}C$, $13V \leq V_{IN} \leq 19V$	-	1	90	
ΔV_O	Load Regulation	$T_J=25^{\circ}C$, $5mA \leq I_{OUT} \leq 1A$	-	15	180	mV
		$T_J=25^{\circ}C$, $250mA \leq I_{OUT} \leq 750mA$	-	5	90	
I_B	Quiescent Current	$I_{OUT}=5mA$, $T_J=25^{\circ}C$	-	3.9	8	mA
ΔI_B	Quiescent Current Change	$I_{OUT}=500mA$, $11.5V \leq V_{IN} \leq 26V$, $T_J=25^{\circ}C$	-	-	1.3	mA
		$5mA \leq I_{OUT} \leq 1A$, $V_{IN}=15V$, $T_J=25^{\circ}C$	-	-	0.5	
eN	Output Noise Voltage	$B=10Hz \sim 100KHz$, $I_{OUT}=50mA$, $T_J=25^{\circ}C$	-	-	75	$\mu V/V_O$
RR	Ripple Rejection	$15V \leq V_{IN} \leq 22.5V$, $f=120Hz$, $I_{OUT}=50mA$, $T_J=25^{\circ}C$	51	67	-	dB
V_D	Dropout Voltage	$T_J=25^{\circ}C$, $I_{OUT}=1A$	-	2	2.5	V
R_O	Output Resistance	$f=1KHz$	-	17	-	$m\Omega$
I_{SC}	Short Circuit Current	$T_J=25^{\circ}C$	-	2.3	2.8	A
$\Delta V_O/\Delta T$	Output Voltage Drift	$-40^{\circ}C \leq T_J \leq 125^{\circ}C$	-	-	1.1	$mV/^{\circ}C$



H7812 Series Electrical Characteristics

$V_{IN}=19V$, $I_{OUT}=500mA$, $C_{IN}=0.33\mu F$, $C_{OUT}=0.1\mu F$, $-40^{\circ}C \leq T_J \leq 125^{\circ}C$ (unless otherwise specified)

Symbol	Parameter	Conditions	H7812AJ/AI/ANE/AE			Units
			Min	Typ	Max	
V_O	Output Voltage	$T_J=25^{\circ}C$, $I_{OUT}=500mA$	11.64	12	12.36	V
		$5mA \leq I_{OUT} \leq 1A$	11.64	12	12.36	
		$14V \leq V_{IN} \leq 30V$, $P_{OUT} \leq 15W$				
ΔV_O	Line Regulation	$T_J=25^{\circ}C$, $14.5V \leq V_{IN} \leq 30V$	-	10	120	mV
		$T_J=25^{\circ}C$, $16V \leq V_{IN} \leq 22V$	-	3	60	
ΔV_O	Load Regulation	$T_J=25^{\circ}C$, $5mA \leq I_{OUT} \leq 1A$	-	12	100	mV
		$T_J=25^{\circ}C$, $250mA \leq I_{OUT} \leq 750mA$	-	4	60	
I_B	Quiescent Current	$I_{OUT}=5mA$, $T_J=25^{\circ}C$	-	3.9	8	mA
ΔI_B	Quiescent Current Change	$I_{OUT}=500mA$, $14.5V \leq V_{IN} \leq 30V$, $T_J=25^{\circ}C$	-	-	1.3	mA
		$5mA \leq I_{OUT} \leq 1A$, $V_{IN}=19V$, $T_J=25^{\circ}C$	-	-	0.5	
eN	Output Noise Voltage	$B=10Hz \sim 100KHz$, $I_{OUT}=50mA$, $T_J=25^{\circ}C$	-	-	90	$\mu V/V_O$
RR	Ripple Rejection	$19V \leq V_{IN} \leq 25V$, $f=120Hz$, $I_{OUT}=50mA$, $T_J=25^{\circ}C$	50	66	-	dB
V_D	Dropout Voltage	$T_J=25^{\circ}C$, $I_{OUT}=1A$	-	2	2.5	V
R_O	Output Resistance	$f=1KHz$	-	18	-	$m\Omega$
I_{SC}	Short Circuit Current	$T_J=25^{\circ}C$	-	2.3	2.8	A
$\Delta V_O/\Delta T$	Output Voltage Drift	$-40^{\circ}C \leq T_J \leq 125^{\circ}C$	-	-	1.6	$mV/^{\circ}C$

Symbol	Parameter	Conditions	H7812BJ/BI/BNE/BE			Units
			Min	Typ	Max	
V_O	Output Voltage	$T_J=25^{\circ}C$, $I_{OUT}=500mA$	11.4	12	12.6	V
		$5mA \leq I_{OUT} \leq 1A$	11.4	12	12.6	
		$14V \leq V_{IN} \leq 30V$, $P_{OUT} \leq 15W$				
ΔV_O	Line Regulation	$T_J=25^{\circ}C$, $14.5V \leq V_{IN} \leq 30V$	-	10	240	mV
		$T_J=25^{\circ}C$, $16V \leq V_{IN} \leq 22V$	-	3	120	
ΔV_O	Load Regulation	$T_J=25^{\circ}C$, $5mA \leq I_{OUT} \leq 1A$	-	12	240	mV
		$T_J=25^{\circ}C$, $250mA \leq I_{OUT} \leq 750mA$	-	4	120	
I_B	Quiescent Current	$I_{OUT}=5mA$, $T_J=25^{\circ}C$	-	3.9	8	mA
ΔI_B	Quiescent Current Change	$I_{OUT}=500mA$, $14.5V \leq V_{IN} \leq 30V$, $T_J=25^{\circ}C$	-	-	1.3	mA
		$5mA \leq I_{OUT} \leq 1A$, $V_{IN}=19V$, $T_J=25^{\circ}C$	-	-	0.5	
eN	Output Noise Voltage	$B=10Hz \sim 100KHz$, $I_{OUT}=50mA$, $T_J=25^{\circ}C$	-	-	90	$\mu V/V_O$
RR	Ripple Rejection	$19V \leq V_{IN} \leq 25V$, $f=120Hz$, $I_{OUT}=50mA$, $T_J=25^{\circ}C$	50	66	-	dB
V_D	Dropout Voltage	$T_J=25^{\circ}C$, $I_{OUT}=1A$	-	2	2.5	V
R_O	Output Resistance	$f=1KHz$	-	18	-	$m\Omega$
I_{SC}	Short Circuit Current	$T_J=25^{\circ}C$	-	2.3	2.8	A
$\Delta V_O/\Delta T$	Output Voltage Drift	$-40^{\circ}C \leq T_J \leq 125^{\circ}C$	-	-	1.6	$mV/^{\circ}C$



Test Circuits

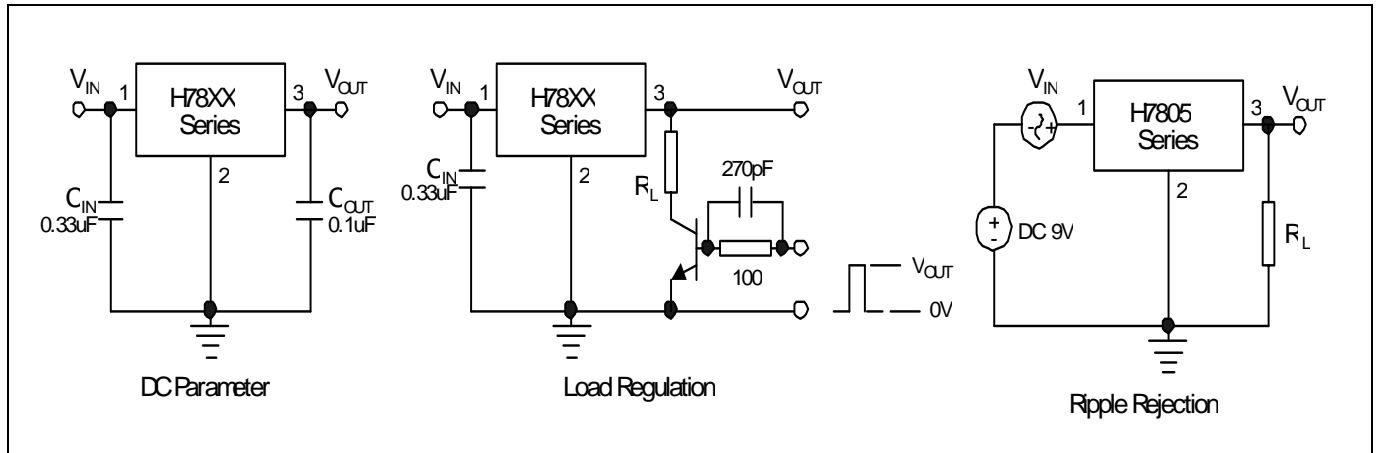

Application Circuits

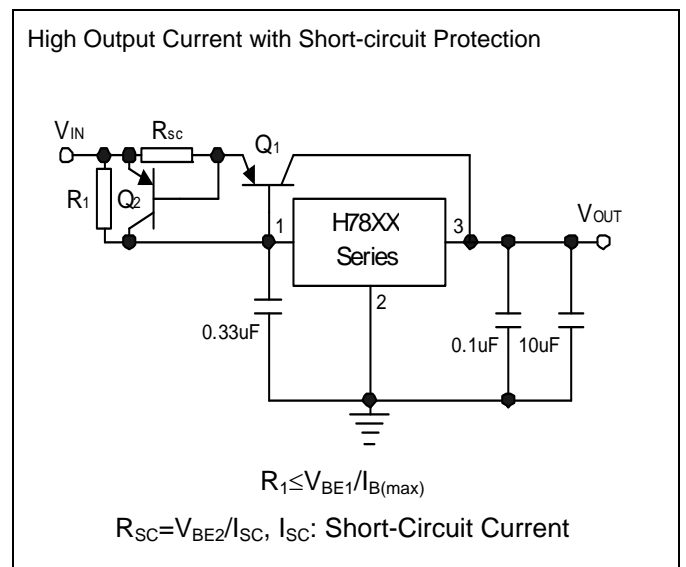
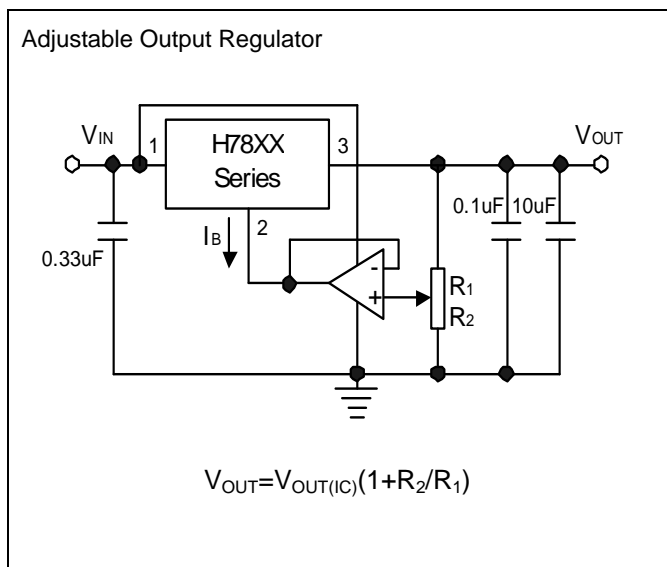
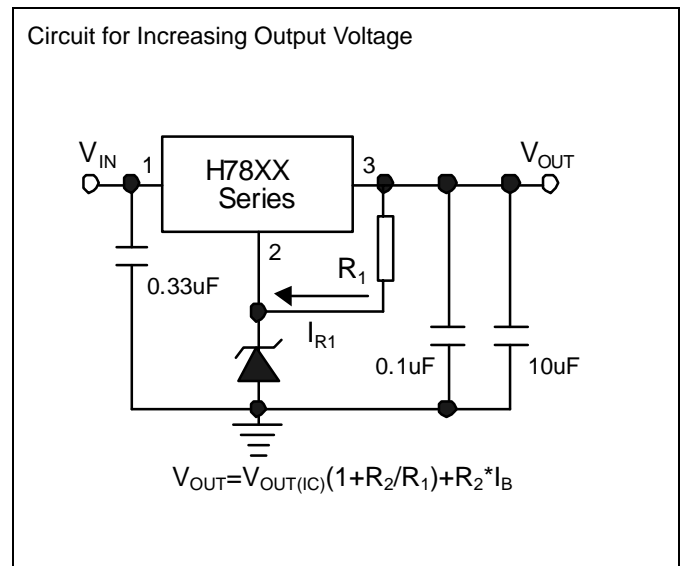
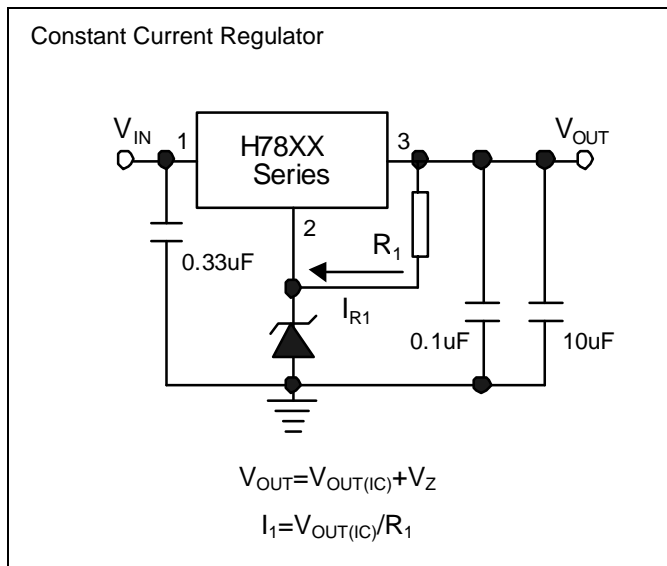



Characteristics Curve

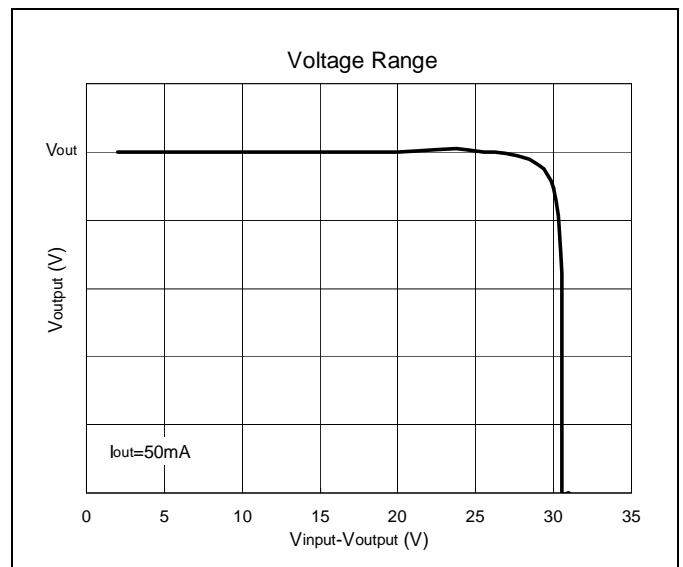
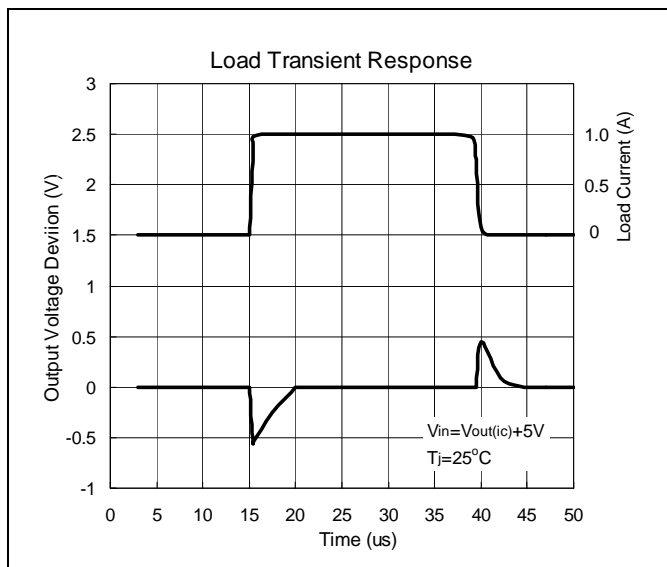
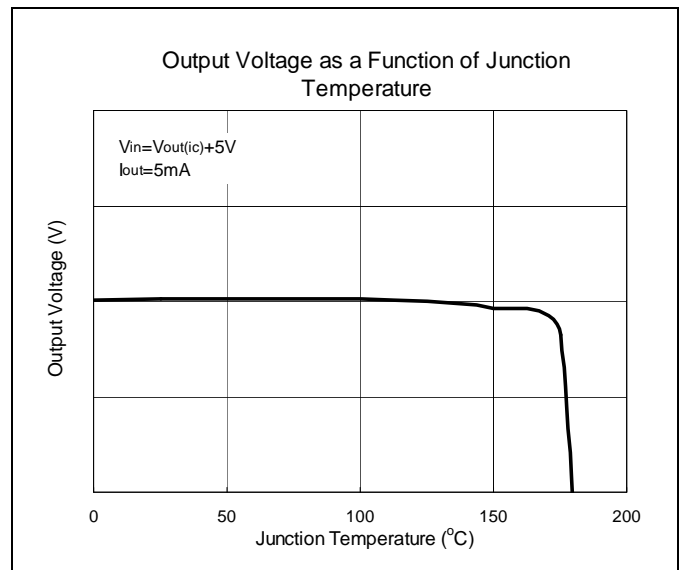
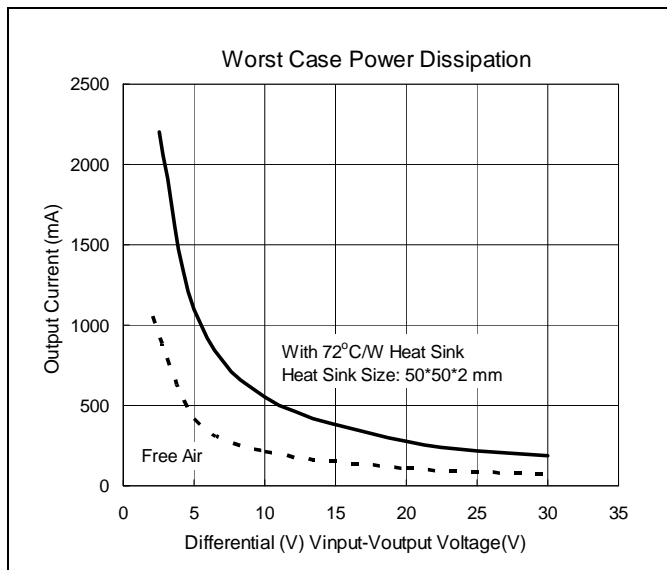
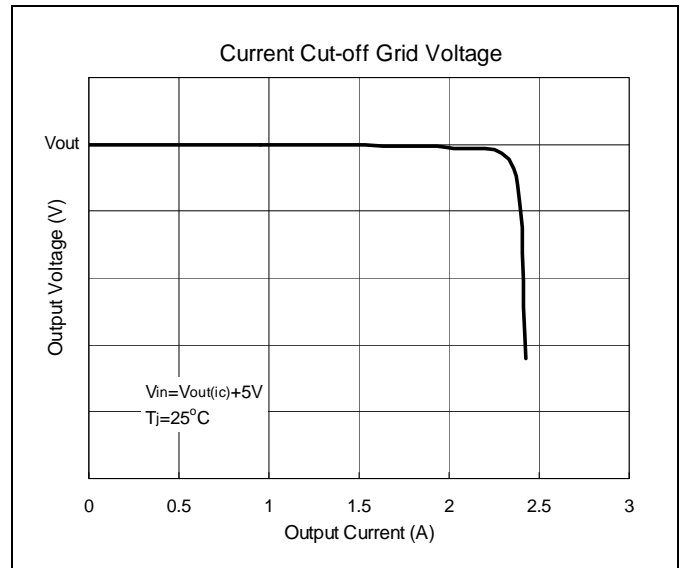
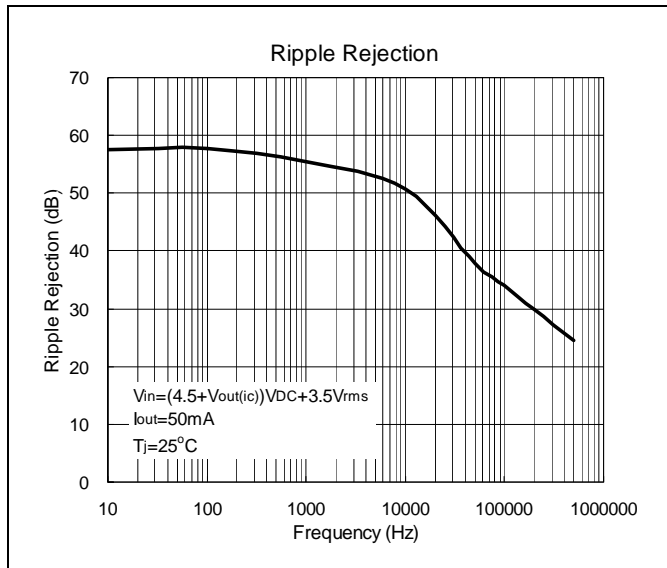



TO-252 Dimension

3-Lead TO-252 Plastic
Surface Mount Package
HSMC Package Code: J

Marking:

Pb Free: "●"
 Halogen Free: "●"
 Normal: None

Note: Green label is used for Pb-free packing

Pin Style: 1.Input 2.Ground 3.Output

Material:

- Lead solder plating: Sn60/Pb40 (Normal), Sn/3.0Ag/0.5Cu or Pure-Tin (Pb-free)
- Mold Compound: Epoxy resin family, flammability solid burning class: UL94V-0

DIM	Min.	Max.
A	6.35	6.80
C	4.80	5.50
F	1.30	1.70
G	5.40	6.25
H	2.20	3.00
L	0.40	0.90
M	2.20	2.40
N	0.90	1.50
a1	0.40	0.65
a2	-	*2.30
a5	0.65	1.05

*: Typical, Unit: mm

3-Lead TO-252 Plastic
Surface Mount Package
HSMC Package Code: J

Marking:

Pb Free: "●"
 Halogen Free: "●"
 Normal: None

Note: Green label is used for pb-free packing

Pin Style: 1.Input 2.Ground 3.Output

Material:

- Lead solder plating: Sn60/Pb40 (Normal), Sn/3.0Ag/0.5Cu or Pure-Tin (Pb-free)
- Mold Compound: Epoxy resin family, flammability solid burning class: UL94V-0

DIM	Min.	Max.
A	6.40	6.80
B	-	6.00
C	5.04	5.64
D	-	*4.34
E	0.40	0.80
F	0.50	0.90
G	5.90	6.30
H	2.50	2.90
I	9.20	9.80
J	0.60	1.00
K	-	0.96
L	0.66	0.86
M	2.20	2.40
N	0.70	1.10
O	0.82	1.22
a1	0.40	0.60
a2	2.10	2.50
y1	-	5°
y2	-	3°

*: Typical, Unit: mm



TO-251 Dimension

Marking:

Pb Free: "●"
 Halogen Free: "●"
 Normal: None

Note: Green label is used for pb-free packing

Pin Style: 1.Input 2.Ground 3.Output

Material:

- Lead solder plating: Sn60/Pb40 (Normal), Sn/3.0Ag/0.5Cu or Pure-Tin (Pb-free)
- Mold Compound: Epoxy resin family, flammability solid burning class: UL94V-0

DIM	Min.	Max.
A	6.35	6.80
C	4.80	5.50
F	1.30	1.70
G	5.40	6.25
H1	6.75	8.00
K	0.50	0.90
K1	0.40	0.90
L	0.90	1.50
M	2.20	2.40
a1	0.40	0.65
a2	-	*2.30

*: Typical, Unit: mm

3-Lead TO-251 Plastic Package
HSMC Package Code: I

Marking:

Pb Free: "●"
 Halogen Free: "●"
 Normal: None

Note: Green label is used for pb-free packing

Pin Style: 1.Input 2.Ground 3.Output

Material:

- Lead solder plating: Sn60/Pb40 (Normal), Sn/3.0Ag/0.5Cu or Pure-Tin (Pb-free)
- Mold Compound: Epoxy resin family, flammability solid burning class: UL94V-0

DIM	Min.	Max.
A	6.40	6.80
B	-	6.00
C	5.04	5.64
D	-	*4.34
E	0.40	0.80
F	0.50	0.90
G	5.90	6.30
H	-	*1.80
H1	-	*9.30
I	-	*16.10
J	-	*0.80
K	-	0.96
K1	-	*0.76
M	2.20	2.40
a1	0.40	0.60
a2	2.10	2.50
y1	-	5°
y2	-	3°

*: Typical, Unit: mm

3-Lead TO-251 Plastic Package
HSMC Package Code: I



SOT-82 Dimension

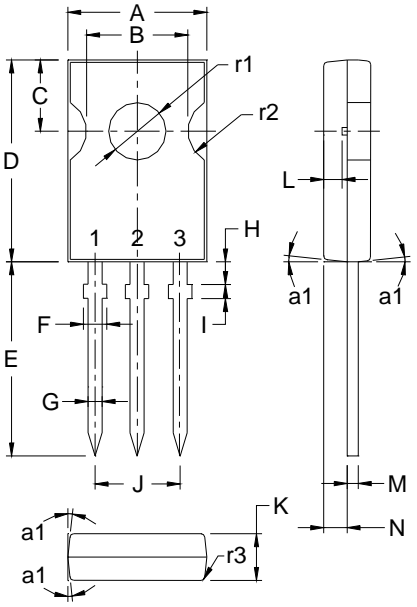

Marking:

Pb Free: "●"
 Halogen Free: "●"
 Normal: None

Product Series (05,06,08,09,12)
 Date Code
 Control Code

Note: Green label is used for pb-free packing
 Pin Style: 1.Input 2.Ground 3.Output

Material:
 • Lead solder plating: Sn60/Pb40 (Normal), Sn/3.0Ag/0.5Cu or Pure-Tin (Pb-free)
 • Mold Compound: Epoxy resin family, flammability solid burning class: UL94V-0

DIM	Min.	Max.
A	7.57	7.67
B	5.44	5.54
C	3.78	3.98
D	10.88	10.98
E	10.25	10.75
F	-	*1.27
G	-	*0.76
H	1.16	1.26
I	-	*0.76
J	4.52	4.62
K	2.49	2.59
L	1.10	1.20
M	-	*0.60
N	1.22	1.32
a1	-	*3°
r1	-	φ3.10
r2	-	R1.70
r3	-	R0.20

*: Typical, Unit: mm

3-Lead SOT-82
 Plastic Package
 HSMC Package Code: NE

TO-220AB Dimension

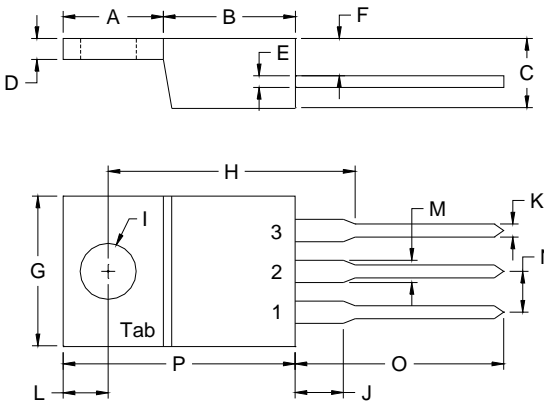

Marking:

Pb Free: "●"
 Halogen Free: "●"
 Normal: None

Product Series (05,06,08,09,12)
 Date Code
 Control Code

Note: Green label is used for pb-free packing
 Pin Style: 1.Input 2.Ground 3.Output

Material:
 • Lead solder plating: Sn60/Pb40 (Normal), Sn/3.0Ag/0.5Cu or Pure-Tin (Pb-free)
 • Mold Compound: Epoxy resin family, flammability solid burning class: UL94V-0

DIM	Min.	Max.
A	5.58	7.49
B	8.38	8.90
C	4.40	4.70
D	1.15	1.39
E	0.35	0.60
F	2.03	2.92
G	9.66	10.28
H	-	*16.25
I	-	*3.83
J	3.00	4.00
K	0.75	0.95
L	2.54	3.42
M	1.14	1.40
N	-	*2.54
O	12.70	14.27
P	14.48	15.87

*: Typical, Unit: mm

3-Lead TO-220AB
 Plastic Package
 HSMC Package Code: E

Important Notice:

- All rights are reserved. Reproduction in whole or in part is prohibited without the prior written approval of HSMC.
- HSMC reserves the right to make changes to its products without notice.
- **HSMC semiconductor products are not warranted to be suitable for use in Life-Support Applications, or systems.**
- HSMC assumes no liability for any consequence of customer product design, infringement of patents, or application assistance.

Head Office

- **Head Office** (Hi-Sincerity Microelectronics Corp.): 3F., No.72, Sec.2, Nanjing E. Rd., Taipei, Taiwan, R.O.C.
 Tel: +886-2-2521-2056, Fax: +886-2-2521-0452
- **AVANTICS**: Shanghai Address: No.399, Cai Lum Rd. Zhangjiang Technology Industrial Park Pudong, Shanghai 201210, China
 Tel: +86-21-6163-7118, Fax: +86-21-6163-7006



Soldering Methods for AVANTICS's Products

1. Storage environment: Temperature=10°C~35°C Humidity=65%±15%

2. Reflow soldering of surface-mount devices

Figure 1: Temperature profile

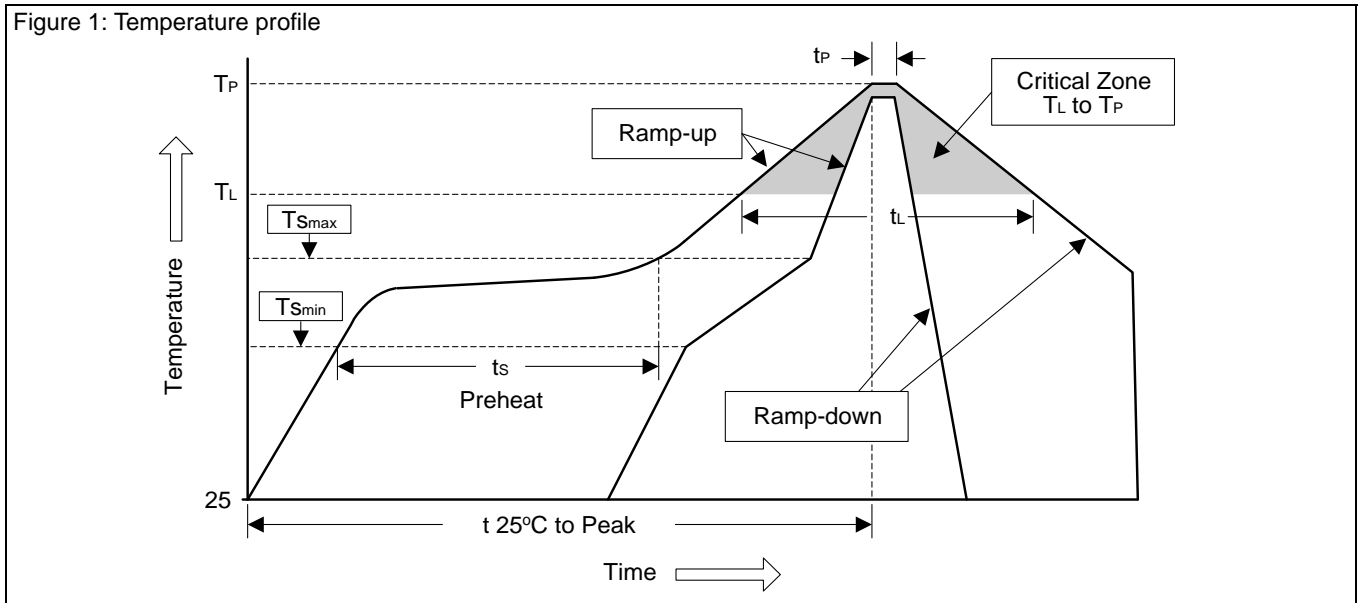

Profile Feature	Sn-Pb Eutectic Assembly	Pb-Free Assembly
Average ramp-up rate (T_L to T_P)	<3°C/sec	<3°C/sec
Preheat		
- Temperature Min (T_{Smin})	100°C	150°C
- Temperature Max (T_{Smax})	150°C	200°C
- Time (min to max) (t_s)	60~120 sec	60~180 sec
T_{Smax} to T_L		
- Ramp-up Rate	<3°C/sec	<3°C/sec
Time maintained above:		
- Temperature (T_L)	183°C	217°C
- Time (t_L)	60~150 sec	60~150 sec
Peak Temperature (T_P)	240°C +0/-5°C	260°C +0/-5°C
Time within 5°C of actual Peak Temperature (t_P)	10~30 sec	20~40 sec
Ramp-down Rate	<6°C/sec	<6°C/sec
Time 25°C to Peak Temperature	<6 minutes	<8 minutes

3. Flow (wave) soldering (solder dipping)

Products	Peak temperature	Dipping time
Pb devices.	245°C ±5°C	5sec ±1sec
Pb-Free devices.	260°C +0/-5°C	5sec ±1sec