

Military & Space Products

32K x 8 STATIC RAM

HC6856

FEATURES

RADIATION

- Fabricated with RICMOS™ IV Bulk 0.8 μm Process ($L_{\text{eff}} = 0.65 \mu\text{m}$)
- Total Dose Hardness through $1 \times 10^6 \text{ rad}(\text{SiO}_2)$
- Neutron Hardness through $1 \times 10^{14} \text{ cm}^{-2}$
- Dynamic and Static Transient Upset Hardness through $1 \times 10^9 \text{ rad}(\text{Si})/\text{s}$
- Soft Error Rate of $< 1 \times 10^{-10}$ upsets/bit-day
- Dose Rate Survivability through $1 \times 10^{12} \text{ rad}(\text{Si})/\text{s}$
- Latchup Free

OTHER

- Listed on SMD #5962-92153. Available as MIL-PRF-38535 QML Class Q and Class V
- Read/Write Cycle Times
≤ 30 ns (Typical)
≤ 40 ns (-55 to 125°C)
- Standby Current of 20 μA (typical)
- Asynchronous Operation
- CMOS or TTL Compatible I/O
- Single 5 V ± 10% Power Supply
- Packaging Options
 - 36-Lead Flat Pack (0.630 in. x 0.650 in.)
 - 28-Lead Flat Pack (0.530 in. x 0.720 in.)
 - 28-Lead DIP, MIL-STD-1835, CDIP2-T28

GENERAL DESCRIPTION

The 32K x 8 Radiation Hardened Static RAM is a high performance 32,768 x 8-bit static random access memory with industry-standard functionality. It is fabricated with Honeywell's radiation hardened technology, and is designed for use in systems operating in radiation environments. The RAM operates over the full military temperature range and requires only a single 5 V ± 10% power supply. The RAM is available with either TTL or CMOS compatible I/O. Power consumption is typically less than 50 mW/MHz in operation, and less than 5 mW/MHz in the low power disabled mode. The RAM read operation is fully asynchronous, with an associated typical access time of 20 ns.

Honeywell's enhanced RICMOS™ IV (Radiation Insensitive CMOS) technology is radiation hardened through the use of advanced and proprietary design, layout, and process hardening techniques. The RICMOS™ IV process is a 5-volt, twin-well CMOS technology with a 170 Å gate oxide and a minimum drawn feature size of 0.8 μm (0.65 μm effective gate length— L_{eff}). Additional features include a three layer interconnect metalization and a lightly doped drain (LDD) structure for improved short channel reliability. High resistivity cross-coupled polysilicon resistors have been incorporated for single event upset hardening.

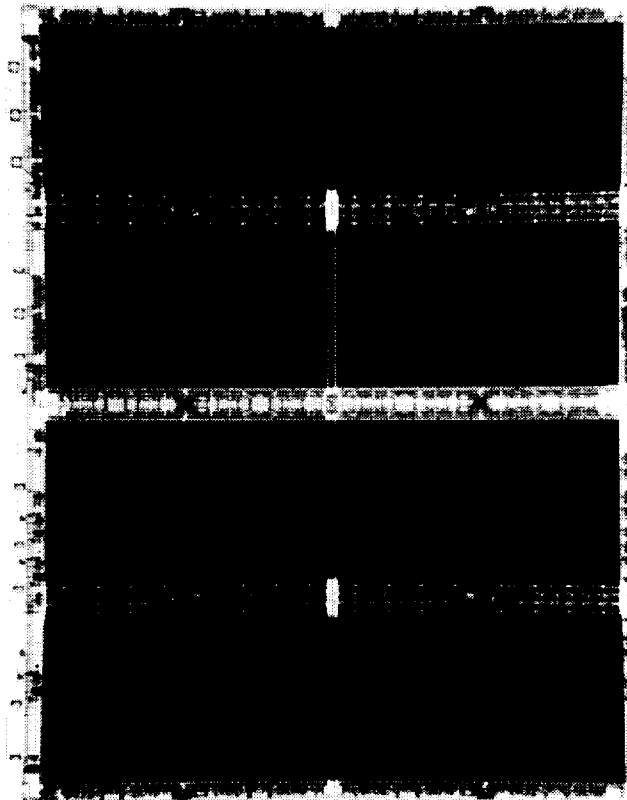

*HONEYWELL
3266

HC6856

FUNCTIONAL DIAGRAM

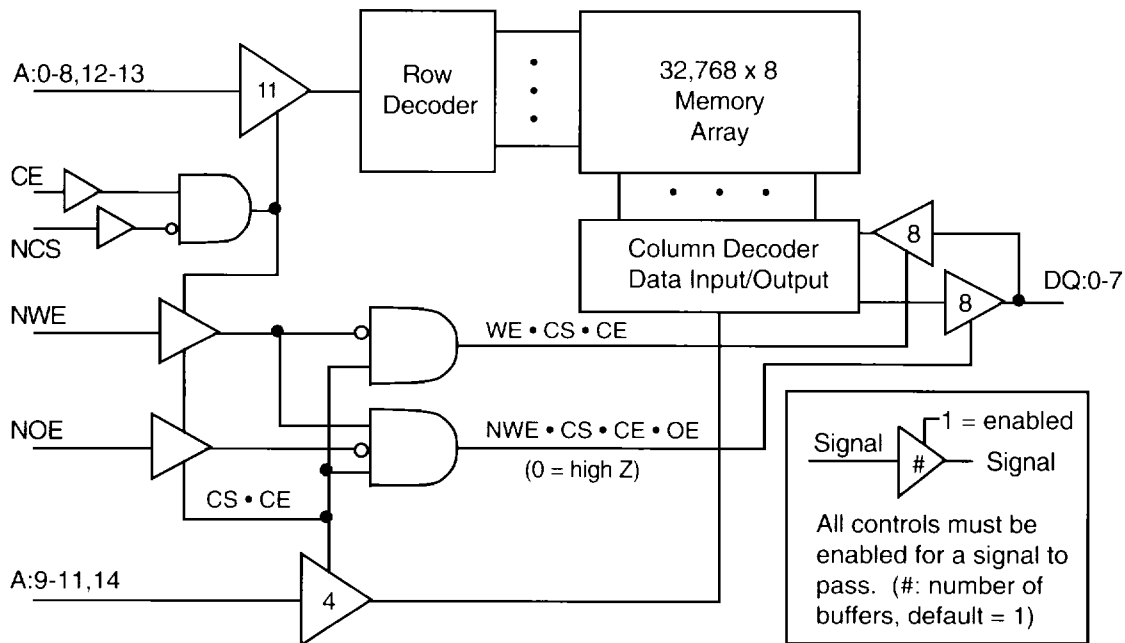

SIGNAL DEFINITIONS

- A: 0-14** Address input pins (A) which select a particular eight-bit word within the memory array.
- DQ: 0-7** Bidirectional data pins which serve as data outputs during a read operation and as data inputs during a write operation.
- NCS** Negative chip select, when at a low level allows normal read or write operation. When at a high level it forces the SRAM to a precharge condition, holds the data output drivers in a high impedance state and disables all the input buffers. If this signal is not used it must be connected to VSS.
- NWE** Negative write enable, when at a low level activates a write operation and holds the data output drivers in a high impedance state. When at a high level it allows normal read operation.
- NOE** Negative output enable, when at a high level holds the data output drivers in a high impedance state. When at a low level, the data output driver state is defined by NCS, NWE and CE. If this signal is not used it must be connected to VSS.
- CE** Chip enable, when at a high level allows normal operation. When at a low level it forces the SRAM to a precharge condition, holds the data output drivers in a high impedance state and disables all the input buffers. If this signal is not used it must be connected to VDD.

TRUTH TABLE

NCS	CE	NWE	NOE	MODE	DQ
L	H	H	L	Read	Data Out
L	H	L	X	Write	Data In
H	X	XX	XX	Deselected	High Z
X	L	XX	XX	Disabled	High Z

Notes:

X: $V_I = V_{IH}$ or V_{IL}

XX: $V_{SS} \leq V_I \leq V_{DD}$

NOE=H: High Z output state maintained for
NCS=X, CE=X, NWE=X

RADIATION CHARACTERISTICS

Total Ionizing Radiation Dose

The RAM will meet all stated functional and electrical specifications over the entire operating temperature range after the specified total ionizing radiation dose. All electrical and timing performance parameters will remain within specifications after rebound at VDD = 5.5 V and T = 125°C extrapolated to ten years of operation. Total dose hardness is assured by wafer level testing of process monitor transistors and RAM product using 10 keV X-ray radiation. Transistor gate threshold shift correlations have been made between 10 keV X-rays applied at a dose rate of 1x10⁵ rad(SiO₂)/min at T = 25°C and gamma rays (Cobalt 60 source) to ensure that wafer level X-ray testing is consistent with standard military radiation test environments.

Transient Pulse Ionizing Radiation

The RAM is capable of writing, reading, and retaining stored data during and after exposure to a transient ionizing radiation pulse of ≤1 μs duration up to 1x10⁹ rad(Si)/s, when applied under recommended operating conditions. To ensure validity of all specified performance parameters before, during, and after radiation (timing degradation during transient pulse radiation is ≤10%), it is suggested that a minimum of 0.8 μF per part of stiffening capacitance be placed between the package (chip) VDD and VSS, with a maximum inductance between the package (chip) and stiffening capacitance of 0.7 nH per part. If there are no operate-through or valid stored data requirements, the capacitance specification can be reduced to a minimum of 0.1 μF per part.

The RAM will meet any functional or electrical specification after exposure to a radiation pulse of ≤ 50 ns duration up to 1x10¹² rad(Si)/s, when applied under recommended operating conditions. Note that the current conducted during the pulse by the RAM inputs, outputs, and power supply may significantly exceed the normal operating levels. The application design must accommodate these effects.

Neutron Radiation

The RAM will meet any functional or timing specification after a total neutron fluence of up to 1x10¹⁴ cm⁻² applied under recommended operating or storage conditions. This assumes an equivalent neutron energy of 1 MeV.

Soft Error Rate

The RAM is capable of soft error rate (SER) performance of <1x10⁻¹⁰ upsets/bit-day, under recommended operating conditions. This hardness level is defined by the Adams 10% worst case cosmic ray environment.

Latchup

The RAM will not latch up due to any of the above radiation exposure conditions when applied under recommended operating conditions. Fabrication with the RICMOS™ p-pi on p+ substrate process and use of proven design techniques, such as double guardbanding, ensure latchup immunity.

RADIATION HARDNESS RATINGS (1)

Parameter	Limits (2)	Units	Test Conditions
Total Dose	≥1x10 ⁶	rad(SiO ₂)	TA=25°C
Transient Dose Rate Upset (3)	≥1x10 ⁹	rad(Si)/s	Pulse width≤1 μs
Transient Dose Rate Survivability	≥1x10 ¹²	rad(Si)/s	Pulse width≤50 ns, X-ray, VDD=6.6 V, TA=25°C
Soft Error Rate: Level A	<1x10 ⁻⁹ (4)	upsets/bit-day	Adams 10% worst case environment
Level Z	<1x10 ⁻¹⁰		
Neutron Fluence	≥1x10 ¹⁴	N/cm ²	1 MeV equivalent energy, Unbiased, TA=25°C

- (1) Device will not latch up due to any of the specified radiation exposure conditions.
- (2) Operating conditions (unless otherwise specified): VDD=4.5 V to 5.5 V, TA=-55°C to 125°C.
- (3) Suggested stiffening capacitance specifications for optimum expected dose rate upset performance is stated above in the text.
- (4) SER <1x10⁻¹⁰ u/b-d from -55 to 80°C.

HC6856

ABSOLUTE MAXIMUM RATINGS (1)

Symbol	Parameter	Rating		Units
		Min	Max	
VDD	Positive Supply Voltage (2)	-0.5	7.0	V
VPIN	Voltage on Any Pin (2)	-0.5	VDD+0.5	V
TSTORE	Storage Temperature (Zero Bias)	-65	150	°C
TSOLDER	Soldering Temperature • Time		270•5	°C•s
PD	Total Package Power Dissipation (3)		2.5	W
IOUT	DC or Average Output Current		25	mA
VPROT	ESD Input Protection Voltage (4)	2000		V
ΘJC	Thermal Resistance (Jct-to-Case)	28 FP/36 FP	2	°C/W
		28 DIP	10	°C/W
TJ	Junction Temperature		175	°C

(1) Stresses in excess of those listed above may result in permanent damage. These are stress ratings only, and operation at these levels is not implied. Frequent or extended exposure to absolute maximum conditions may affect device reliability.

(2) Voltage referenced to VSS.

(3) RAM power dissipation (IDDSB + IDDOP) plus RAM output driver power dissipation due to external loading must not exceed this specification.

(4) Class 2 electrostatic discharge (ESD) input protection. Tested per MIL-STD-883, Method 3015 by DESC certified lab.

RECOMMENDED OPERATING CONDITIONS

Symbol	Parameter	Description			Units
		Min	Typ	Max	
VDD	Supply Voltage (referenced to VSS)	4.5	5.0	5.5	V
TA	Ambient Temperature	-55	25	125	°C
VPIN	Voltage on Any Pin (referenced to VSS)	-0.3		VDD+0.3	V

CAPACITANCE (1)

Symbol	Parameter	Typical	Worst Case		Units	Test Conditions
				Max		
CI	Input Capacitance	4		6	pF	VI=VDD or VSS, f=1 MHz
CO	Output Capacitance	6.5		8	pF	VIO=VDD or VSS, f=1 MHz

(1) This parameter is tested during initial design characterization only.

DATA RETENTION CHARACTERISTICS

Symbol	Parameter (2)	Typical (1)	Worst Case		Units	Test Conditions
			Min	Max		
VDR	Data Retention Voltage (3)	2.0	2.5		V	NCS=VDR VI=VDR or VSS
IDR	Data Retention Current	150		400	μA	NCS=VDD=VDR VI=VDR or VSS

(1) Typical operating conditions: TA= 25 C, pre-radiation.

(2) Worst case operating conditions: TA = -55 C to +125 C, post total dose at 25 C.

(3) To maintain valid data storage during transient radiation, VDD must be held within the recommended operating range.

DC ELECTRICAL CHARACTERISTICS

Symbol	Parameter	Typical (1)	Worst Case (2)		Units	Test Conditions (3)	
			Min	Max			
IDDSB1	Static Supply Current	0.02		1.2	mA	$V_{IH}=V_{DD}$, $I_O=0$ $V_{IL}=V_{SS}$ Inputs Stable	
IDDSB2	Static Supply Current with Chip Disabled	0.02		1.2	mA	$CE=V_{SS}$ or $NCS=V_{DD}$ $I_O=0$, $V_{SS} \leq V_I \leq V_{DD}$ (4)	
IDDOPW	Dynamic Supply Current, Selected (Write)	5.5		7.5	mA	$f=1$ MHz, $I_O=0$, $CE=V_{IH}=V_{DD}$ $NCS=V_{IL}=V_{SS}$ (5)	
IDDOPR	Dynamic Supply Current, Selected (Read)	4.5		6.5	mA	$f=1$ MHz, $I_O=0$, $CE=V_{IH}=V_{DD}$ $NCS=V_{IL}=V_{SS}$ (5)	
I _I	Input Leakage Current	± 0.05	-5	+5	μ A	$V_{SS} \leq V_I \leq V_{DD}$	
I _{OZ}	Output Leakage Current	± 0.1	-10	10	μ A	$V_{SS} \leq V_{IO} \leq V_{DD}$ Output=high Z	
V _{IL}	Low-Level Input Voltage	CMOS	1.9		0.3xV _{DD}	V	V _{DD} =4.5V
		TTL	1.3		0.8	V	V _{DD} =4.5V
V _{IH}	High-Level Input Voltage	CMOS	3.0	0.7xV _{DD}		V	V _{DD} =5.5V
		TTL	1.7	2.2		V	V _{DD} =5.5V
V _{OL}	Low-Level Output Voltage		0.2		0.4	V	V _{DD} =4.5V, I _{OL} =10 mA
					0.05	V	V _{DD} =4.5V, I _{OL} =200 μ A
V _{OH}	High-Level Output Voltage		4.8			V	V _{DD} =4.5V, I _{OH} =-5 mA
				4.2		V	V _{DD} =4.5V, I _{OH} =-200 μ A

(1) Typical operating conditions: V_{DD}= 5.0 V, T_A=25°C, pre-radiation.

(2) Worst case operating conditions: V_{DD}=4.5 V to 5.5 V, T_A=-55°C to +125°C, post total dose at 25°C.

(3) Input high = V_{IH} \geq V_{DD}-0.3V, input low = V_{IL} \leq 0.3V

(4) Guaranteed but not tested.

(5) All inputs switching. DC average current.

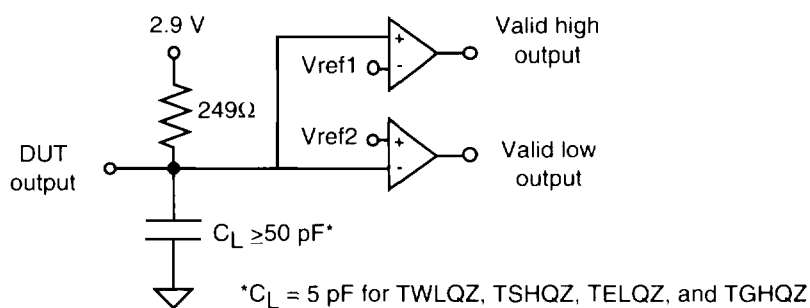

Tester Equivalent Load Circuit

WRITE CYCLE AC TIMING CHARACTERISTICS (1)

Symbol	Parameter	Typical (2)	Worst Case (3)				Units
			SER <1E-9 (4)		SER <1E-10		
			Min	Max	Min	Max	
TAVAVW	Write Cycle Time (5)	30	40		60		ns
TWLWH	Write Enable Write Pulse Width	25	35		55		ns
TSLWH	Chip Select to End of Write Time	25	35		55		ns
TDVWH	Data Valid to End of Write Time	20	30		50		ns
TAVWH	Address Valid to End of Write Time	25	35		55		ns
TWHDX	Data Hold Time after End of Write Time	0	0		0		ns
TAVWL	Address Valid Setup to Start of Write Time	0	0		0		ns
TWHAX	Address Valid Hold after End of Write Time	0	0		0		ns
TWLQZ	Write Enable to Output Disable Time	5	0	10	0	10	ns
TWHQX	Write Disable to Output Enable Time	15	5		5		ns
TWHWL	Write Disable to Write Enable Pulse Width	4	5		5		ns
TEHWH	Chip Enable to End of Write Time	25	35		55		ns

(1) Test conditions: input switching levels VIL/VIH=0.5V/VDD-0.5V (CMOS), VIL/VIH=0V/3V (TTL), input rise and fall times <1 ns/V, input and output timing reference levels shown in the Tester AC Timing Characteristics table, capacitive output loading 0 pF, or equivalent capacitive load of 5 pF for TWLQZ.

(2) Typical operating conditions: VDD=5.0 V, TA=25°C, pre-radiation.

(3) Worst case operating conditions: VDD=4.5 V to 5.5 V, -55 to 125°C, post total dose at 25°C.

(4) SER ≤1E-10 u/b-d from -55 to 80°C.

(5) TAVAVW= TWLWH + TWHWL

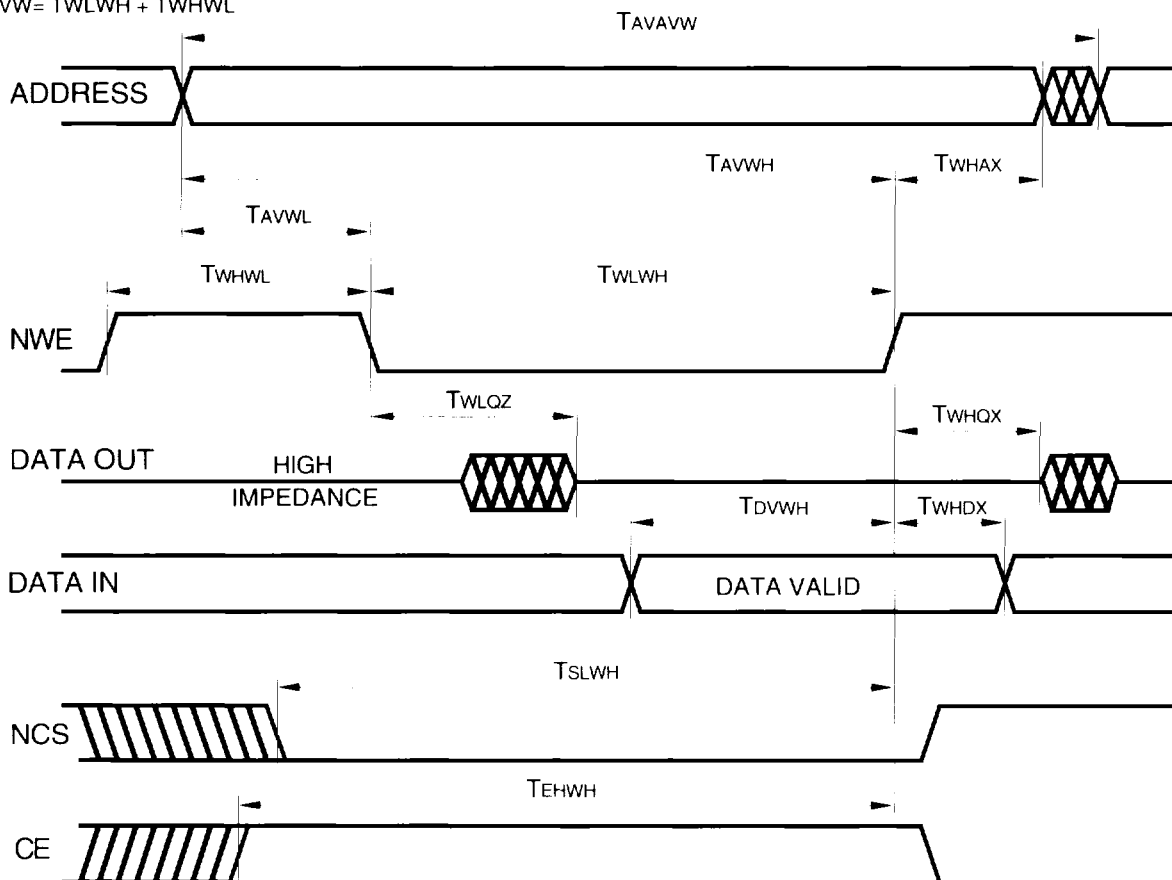

DYNAMIC ELECTRICAL CHARACTERISTICS

Read Cycle

The RAM is asynchronous in operation, allowing the read cycle to be controlled by address, chip select (NCS), or chip enable (CE) (refer to Read Cycle timing diagram). To perform a valid read operation, both chip select and output enable (NOE) must be low and chip enable and write enable (NWE) must be high. The output drivers can be controlled independently by the NOE signal. Consecutive read cycles can be executed with NCS held continuously low, and with CE held continuously high.

For an address activated read cycle, NCS and CE must be valid prior to or coincident with the activating address edge transition(s). Any amount of toggling or skew between address edge transitions is permissible; however, data outputs will become valid TAVQV time following the latest occurring address edge transition. The minimum address activated read cycle time is TAVAV. When the RAM is operated at the minimum address activated read cycle time, the data outputs will remain valid on the RAM I/O until TAXQX time following the next sequential address transition.

To control a read cycle with NCS, all addresses and CE must be valid prior to or coincident with the enabling NCS edge transition. Address or CE edge transitions can occur later than the specified setup times to NCS; however, the valid data access time will be delayed. Any address edge transition, which occurs during the time when NCS is low, will initiate a new read access, and data outputs will not become valid until TAVQV time following the address edge transition. Data outputs will enter a high impedance state TSHQZ time following a disabling NCS edge transition.

To control a read cycle with CE, all addresses and NCS must be valid prior to or coincident with the enabling CE edge transition. Address or NCS edge transitions can occur later than the specified setup times to CE; however, the valid data access time will be delayed. Any address edge transition which occurs during the time when CE is high will initiate a new read access, and data outputs will not become valid until TAVQV time following the address edge transition. Data outputs will enter a high impedance state TELQZ time following a disabling CE edge transition.

Write Cycle

The write operation is synchronous with respect to the address bits, and control is governed by write enable (NWE), chip select (NCS), or chip enable (CE) edge transitions (refer to Write Cycle timing diagrams). To perform a write operation, both NWE and NCS must be low, and CE must be high. Consecutive write cycles can be performed with NWE or NCS held continuously low, or CE held continuously high. At least one of the control signals must transition to the opposite state between consecutive write operations.

The write mode can be controlled via three different control signals: NWE, NCS, and CE. All three modes of control are similar except the NCS and CE controlled modes actually disable the RAM during the write recovery pulse. Only the NWE controlled mode is shown in the table and diagram on the previous page for simplicity; however, each mode of control provides the same write cycle timing characteristics. Thus, some of the parameter names referenced below are not shown in the write cycle table or diagram, but indicate which control pin is in control as it switches high or low.

To write data into the RAM, NWE and NCS must be held low and CE must be held high for at least TWLWH/TSLSH/TEHEL time. Any amount of edge skew between the signals can be tolerated, and any one of the control signals can initiate or terminate the write operation. For consecutive write operations, write pulses must be separated by the minimum specified TWHWL/TSHSL/TELEH time. Address inputs must be valid at least TAVWL/TAVSL/TAVEH time before the enabling NWE/NCS/CE edge transition, and must remain valid during the entire write time. A valid data overlap of write pulse width time of TDVWH/TDVSH/TDVEL, and an address valid to end of write time of TAVWH/TAVSH/TAVEL also must be provided for during the write operation. Hold times for address inputs and data inputs with respect to the disabling NWE/NCS/CE edge transition must be a minimum of TWHAX/TSHAX/TELAX time and TWHDX/TSHDX/TELDX time, respectively. The minimum write cycle time is TAVAV.

TESTER AC TIMING CHARACTERISTICS

	TTL I/O Configuration	CMOS I/O Configuration
Input Levels*		
Output Sense Levels	<p>High Z = 2.9V</p>	<p>High Z = 2.9V</p>

* Input rise and fall times <1 ns/V

QUALITY AND RADIATION HARDNESS ASSURANCE

Honeywell maintains a high level of product integrity through process control, utilizing statistical process control, a complete "Total Quality Assurance System," a computer data base process performance tracking system, and a radiation hardness assurance strategy.

The radiation hardness assurance strategy starts with a technology that is resistant to the effects of radiation. Radiation hardness is assured on every wafer by irradiating test structures as well as SRAM product, and then monitoring key parameters which are sensitive to ionizing radiation. Conventional MIL-STD-883 TM 5005 Group E testing, which includes total dose exposure with Cobalt 60, may also be performed as required. This Total Quality approach ensures our customers of a reliable product by engineering in reliability, starting with process development and continuing through product qualification and screening.

SCREENING LEVELS

Honeywell offers several levels of device screening to meet your system needs. "Engineering Devices" are available with limited performance and screening for breadboarding and/or evaluation testing. Hi-Rel Level B and S devices undergo additional screening per the requirements of MIL-STD-883. As a QML supplier, Honeywell also offers QML Class Q and V devices per MIL-PRF-38535 and are available per the applicable Standard Military Drawing (SMD).

QML devices offer ease of procurement by eliminating the need to create detailed specifications and offer benefits of improved quality and cost savings through standardization.

RELIABILITY

Honeywell understands the stringent reliability requirements that space and defense systems require and has extensive experience in reliability testing on programs of this nature. This experience is derived from comprehensive testing of VLSI processes. Reliability attributes of the RICMOS™ process were characterized by testing specially designed irradiated and non-irradiated test structures from which specific failure mechanisms were evaluated. These specific mechanisms included, but were not limited to, hot carriers, electromigration and time dependent dielectric breakdown. This data was then used to make changes to the design models and process to ensure more reliable products.

In addition, the reliability of the RICMOS™ process and product in a military environment was monitored by testing irradiated and non-irradiated circuits in accelerated dynamic life test conditions. Packages are qualified for product use after undergoing Groups B & D testing as outlined in MIL-STD-883, TM 5005, Class S. The product is qualified by following a screening and testing flow to meet the customer's requirements. Quality conformance testing is performed as an option on all production lots to ensure the ongoing reliability of the product.

HC6856

PACKAGING

The 32K x 8 SRAM is offered in a custom 36-lead flat pack (FP), 28-Lead FP, or standard 28-lead DIP. Each package is constructed of multilayer ceramic (Al_2O_3) and features internal power and ground planes. The 36-lead FP also features a non-conductive ceramic tie bar on the lead frame. The purpose of the tie bar is to allow electrical testing of the device, while preserving the lead integrity during shipping and handling, up to the point of lead forming and

insertion. Ceramic chip capacitors can be mounted to the package by the user to maximize supply noise decoupling and increase board packing density. These capacitors attach directly to the internal package power and ground planes. This design minimizes resistance and inductance of the bond wire and package, both of which are critical in a transient radiation environment. All NC (no connect) pins must be connected to either VDD, VSS or an active driver to prevent charge build up in the radiation environment.

28-LEAD DIP & FP PINOUT

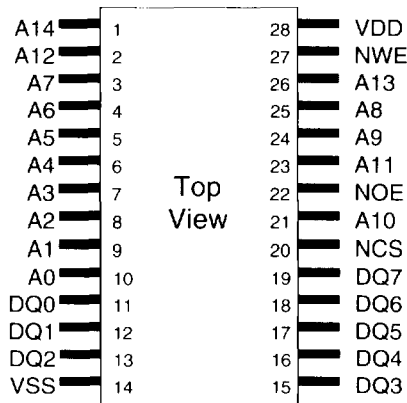

36-LEAD FLAT PACK PINOUT

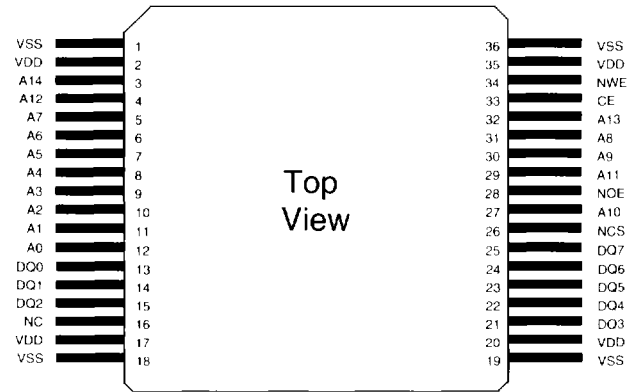

36-LEAD FLAT PACK (22017194-001)

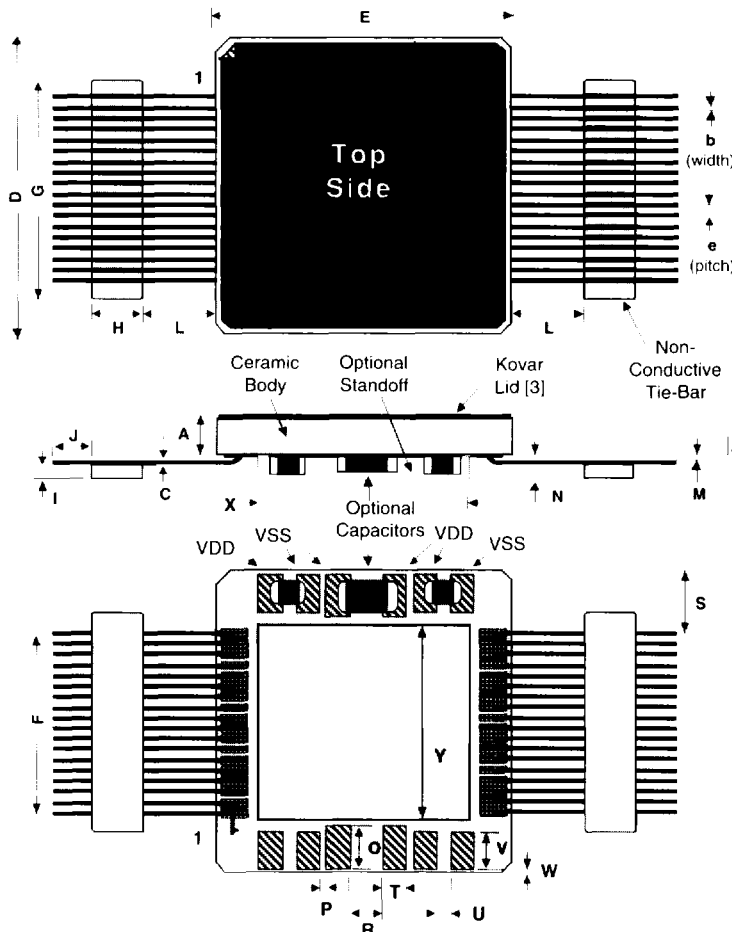

All dimensions are in inches [1]

A	0.095 ± 0.010	M	0.008 ± 0.003
b	0.008 ± 0.002	N	0.050 ± 0.010
C	0.005 to 0.0075	O	0.090 ref
D	0.650 ± 0.010	P	0.015 ref
E	0.630 ± 0.007	R	0.075 ref
e	0.025 ± 0.002 [2]	S	0.113 ± 0.010
F	0.425 ± 0.005 [2]	T	0.050 ref
G	0.525 ± 0.005	U	0.030 ref
H	0.135 ± 0.005	V	0.080 ref
I	0.030 ± 0.005	W	0.005 ref
J	0.080 typ.	X	0.450 ref
L	0.285 ± 0.015	Y	0.400 ref

[1] Parts delivered with leads unformed

[2] At tie bar

[3] Lid tied to VSS

28-LEAD FLAT PACK (22017362-001)

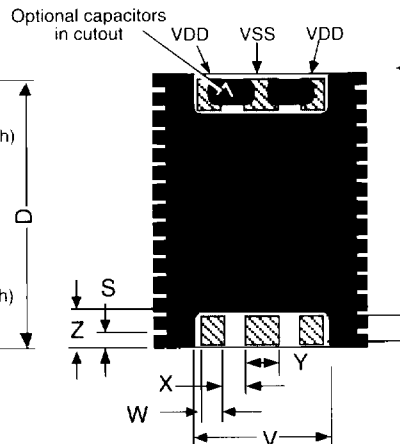
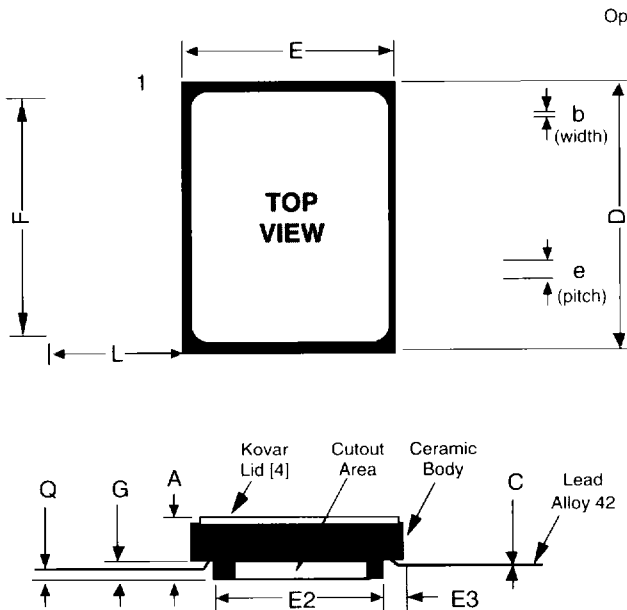

All dimensions in inches

A	0.135 ± 0.015
b	0.015 ± 0.002
C	0.004 to 0.009
D	0.720 ± 0.008
e	0.050 ± 0.005 [1]
E	0.530 ± 0.008
E2	0.420 ± 0.008
E3	0.055 ref
F	0.650 ± 0.005 [2]
G	0.050 ± 0.005
L	0.295 min [3]
Q	0.026 to 0.045
S	0.035 ± 0.010
U	0.065 ref
V	0.300 ref
W	0.050 ref
X	0.030 ref
Y	0.100 ref
Z	0.080 ref

- [1] BSC - Basic lead spacing between centers
- [2] Where lead is brazed to package
- [3] Parts delivered with leads unformed
- [4] Lid connected to VSS

28-LEAD DIP (22017502-001)

For 28-Lead DIP description, see MIL-STD-1835, Type CDIP2-T28, Config. C, Dimensions D-10

DYNAMIC BURN-IN DIAGRAM

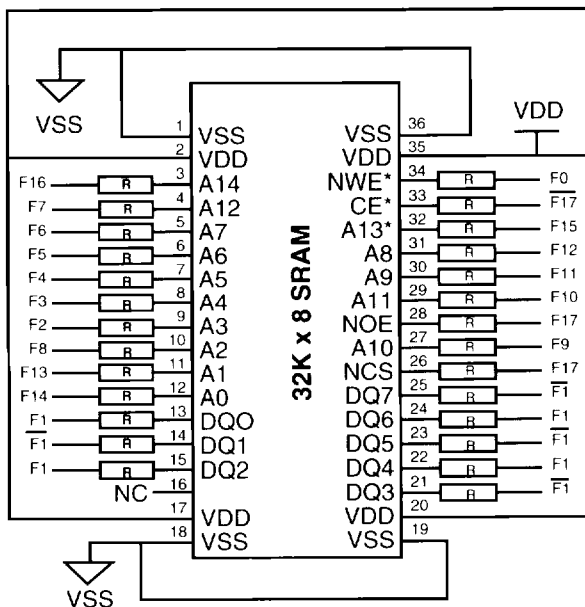

VDD = 6.5V, R ≤ 10 KΩ, VIH = VDD, VIL = VSS
 Ambient Temperature ≥ 125 °C, F0 ≥ 100 KHz Sq Wave
 Frequency of F1 = F0/2, F2 = F0/4, F3 = F0/8, etc.

STATIC BURN-IN DIAGRAM

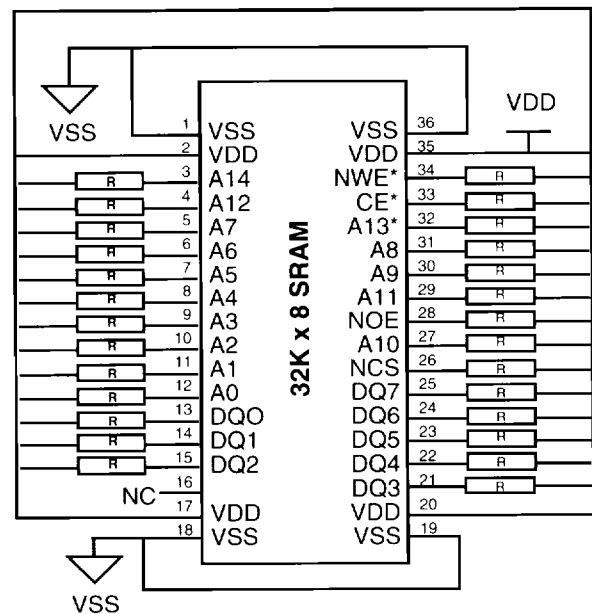

VDD = 5.5V, R ≤ 10 KΩ
 Ambient Temperature ≥ 125 °C

NOTE — *Denotes package pinout option dependent (28-Lead DIP/FP diagrams not shown but have similar connections)

HC6856

ORDERING INFORMATION (1)

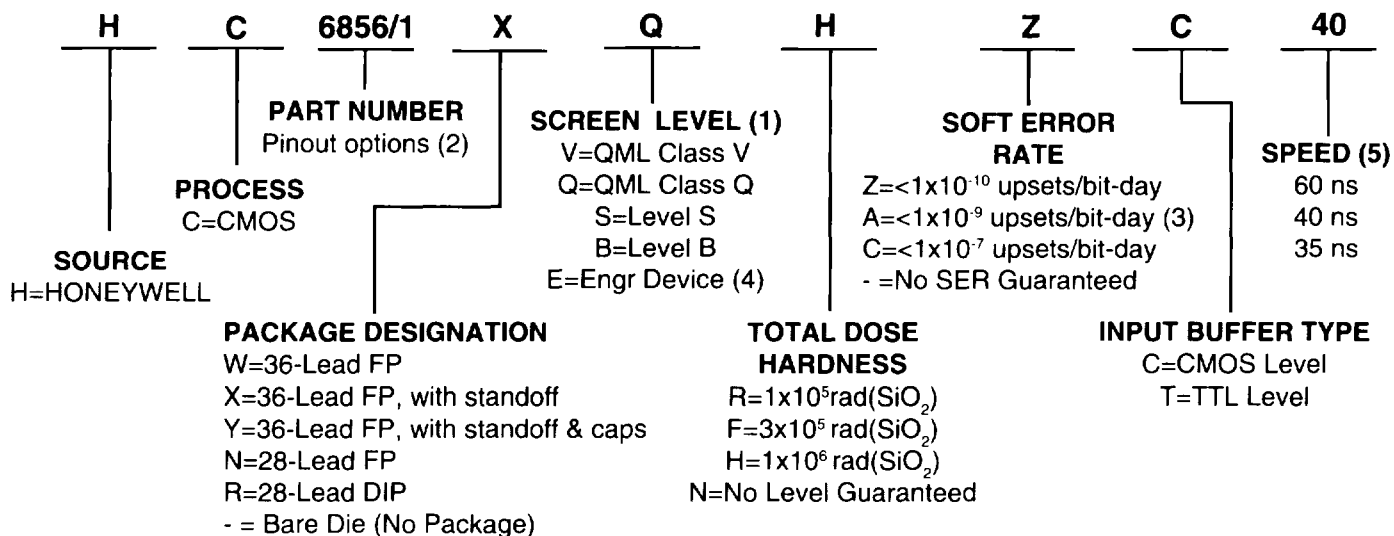

(1) Orders may be faxed to 612-954-2051. Please contact our Customer Logistics Department at 612-954-2888 for further information.

(2) Pinout options:

	36-Lead FP		28-Lead FP & DIP	
	pin 32	pin 33	pin 34	
HC6856/1	A13	CE	NWE	JEDEC Pinout
HC6856/2	CE	NWE	A13	N/A

(3) SER $<1 \times 10^{-10}$ u/b-d from -55 to 80°C.

(4) Engineering Device description: Parameters are tested from -55 to 125°C, 24 hr burn-in, no radiation guaranteed.

(5) Only specified for Engineering Devices. Number defines worst case maximum Write Cycle time in nano-seconds (ns).

Contact Factory with other needs.

**To learn more about Honeywell Solid State Electronics Center,
visit our web site at <http://www.ssec.honeywell.com>**

Honeywell reserves the right to make changes to any products or technology herein to improve reliability, function or design. Honeywell does not assume any liability arising out of the application or use of any product or circuit described herein; neither does it convey any license under its patent rights nor the rights of others.

Honeywell

Helping You Control Your World